

# TP-LINK®

## User Guide

**TL-WR810N**

**300Mbps Wi-Fi Pocket Router/AP/TV  
Adapter/Repeater**



REV: 1.1.0

1910011573

## **COPYRIGHT & TRADEMARKS**

Specifications are subject to change without notice. **TP-LINK®** is a registered trademark of TP-LINK TECHNOLOGIES CO., LTD. Other brands and product names are trademarks or registered trademarks of their respective holders.

No part of the specifications may be reproduced in any form or by any means or used to make any derivative such as translation, transformation, or adaptation without permission from TP-LINK TECHNOLOGIES CO., LTD. Copyright © 2016 TP-LINK TECHNOLOGIES CO., LTD. All rights reserved.

<http://www.tp-link.com>

## FCC STATEMENT



This equipment has been tested and found to comply with the limits for a Class B digital device, pursuant to part 15 of the FCC Rules. These limits are designed to provide reasonable protection against harmful interference in a residential installation. This equipment generates, uses and can radiate radio frequency energy and, if not installed and used in accordance with the instructions, may cause harmful interference to radio communications. However, there is no guarantee that interference will not occur in a particular installation. If this equipment does cause harmful interference to radio or television reception, which can be determined by turning the equipment off and on, the user is encouraged to try to correct the interference by one or more of the following measures:

- Reorient or relocate the receiving antenna.
- Increase the separation between the equipment and receiver.
- Connect the equipment into an outlet on a circuit different from that to which the receiver is connected.
- Consult the dealer or an experienced radio/ TV technician for help.

This device complies with part 15 of the FCC Rules. Operation is subject to the following two conditions:

- 1) This device may not cause harmful interference.
- 2) This device must accept any interference received, including interference that may cause undesired operation.

Any changes or modifications not expressly approved by the party responsible for compliance could void the user's authority to operate the equipment.

Note: The manufacturer is not responsible for any radio or TV interference caused by unauthorized modifications to this equipment. Such modifications could void the user's authority to operate the equipment.

### **FCC RF Radiation Exposure Statement:**

This equipment complies with FCC RF radiation exposure limits set forth for an uncontrolled environment. This device and its antenna must not be co-located or operating in conjunction with any other antenna or transmitter.

“To comply with FCC RF exposure compliance requirements, this grant is applicable to only Mobile Configurations. The antennas used for this transmitter must be installed to provide a

separation distance of at least 20 cm from all persons and must not be co-located or operating in conjunction with any other antenna or transmitter.”

## CE Mark Warning

# CE 1588

This is a Class B product. In a domestic environment, this product may cause radio interference, in which case the user may be required to take adequate measures.

## RF Exposure Information

This device meets the EU requirements (1999/519/EC) on the limitation of exposure of the general public to electromagnetic fields by way of health protection.

The device complies with RF specifications when the device used at 20 cm from your body.

## National Restrictions

This device is intended for home and office use in all EU countries (and other countries following the EU directive 1999/5/EC) without any limitation except for the countries mentioned below:

Country	Restriction	Reason/remark
Belarus	Not implemented	
Norway	Implemented	This subsection does not apply for the geographical area within a radius of 20 km from the centre of Ny-Ålesund on Svalbard.
Italy	Implemented	The public use is subject to general authorisation by the respective service provider.
Russian Federation	Limited implementation	<b>1. SRD with FHSS modulation</b> 1.1. Maximum 2.5 mW e.i.r.p. 1.2. Maximum 100 mW e.i.r.p. Permitted for use SRD for outdoor applications without restriction on installation height only for purposes of gathering telemetry information for automated monitoring and resources accounting systems. Permitted to use SRD for other purposes for outdoor applications only when the installation height is not exceeding 10 m above the ground surface. 1.3. Maximum 100 mW e.i.r.p. Indoor applications. <b>2. SRD with DSSS and other than FHSS wideband modulation</b> 2.1. Maximum mean e.i.r.p. density is 2 mW/MHz. Maximum 100 mW e.i.r.p. 2.2. Maximum mean e.i.r.p. density is 20 mW/MHz. Maximum

---

100 mW e.i.r.p. It is permitted to use SRD for outdoor applications only for purposes of gathering telemetry information for automated monitoring and resources accounting systems or security systems.

2.3. Maximum mean e.i.r.p. density is 10 mW/MHz. Maximum 100 mW e.i.r.p. Indoor applications.

---

Ukraine	Limited implementation	e.i.r.p. $\leq 100$ mW with built-in antenna with amplification factor up to 6 dBi.
---------	------------------------	---

---

ATTENTION: Due to EU law, the country settings must be identical to the country where the device is operating (important due to non-harmonised frequencies in the EU).

## Canadian Compliance Statement

This device complies with Industry Canada license-exempt RSSs. Operation is subject to the following two conditions:

- 1) This device may not cause interference, and
- 2) This device must accept any interference, including interference that may cause undesired operation of the device.

Le présent appareil est conforme aux CNR d'Industrie Canada applicables aux appareils radio exempts de licence. L'exploitation est autorisée aux deux conditions suivantes :

- 1) l'appareil ne doit pas produire de brouillage;
- 2) l'utilisateur de l'appareil doit accepter tout brouillage radioélectrique subi, même si le brouillage est susceptible d'en compromettre le fonctionnement.

## Radiation Exposure Statement:

This equipment complies with IC radiation exposure limits set forth for an uncontrolled environment. This equipment should be installed and operated with minimum distance 20cm between the radiator & your body.

## Déclaration d'exposition aux radiations:

Cet équipement est conforme aux limites d'exposition aux rayonnements IC établies pour un environnement non contrôlé. Cet équipement doit être installé et utilisé avec un minimum de 20 cm de distance entre la source de rayonnement et votre corps.

## Industry Canada Statement

CAN ICES-3 (B)/NMB-3(B)

## Korea Warning Statements

당해 무선설비는 운용중 전파혼신 가능성이 있음.

## NCC Notice

注意！

依據 低功率電波輻射性電機管理辦法

第十二條 經型式認證合格之低功率射頻電機，非經許可，公司、商號或使用者均不得擅自變更頻率、加大功率或變更原設計之特性或功能。

第十四條 低功率射頻電機之使用不得影響飛航安全及干擾合法通行；經發現有干擾現象時，應立即停用，並改善至無干擾時方得繼續使用。前項合法通信，指依電信規定作業之無線電信。低功率射頻電機需忍受合法通信或工業、科學以及醫療用電波輻射性電機設備之干擾。

減少電磁波影響，請妥適使用。

## BSMI Notice

安全諮詢及注意事項

- 請使用原裝電源供應器或只能按照本產品注明的電源類型使用本產品。
- 清潔本產品之前請先拔掉電源線。請勿使用液體、噴霧清潔劑或濕布進行清潔。
- 注意防潮，請勿將水或其他液體潑灑到本產品上。
- 插槽與開口供通風使用，以確保本產品的操作可靠並防止過熱，請勿堵塞或覆蓋開口。
- 請勿將本產品置放於靠近熱源的地方。除非有正常的通風，否則不可放在密閉位置中。
- 請不要私自打開機殼，不要嘗試自行維修本產品，請由授權的專業人士進行此項工作。



Продукт сертифіковано згідно с правилами системи УкрСЕПРО на відповідність вимогам нормативних документів та вимогам, що передбачені чинними законодавчими актами України.





## Safety Information

- When product has power button, the power button is one of the way to shut off the product; when there is no power button, the only way to completely shut off power is to disconnect the product or the power adapter from the power source.
- Don't disassemble the product, or make repairs yourself. You run the risk of electric shock and voiding the limited warranty. If you need service, please contact us.
- Avoid water and wet locations.

This product can be used in the following countries:

AT	BG	BY	CA	CZ	DE	DK	EE
ES	FI	FR	GB	GR	HU	IE	IT
LT	LV	MT	NL	NO	PL	PT	RO
RU	SE	SG	SK	TR	UA	US	

## Explanation of the symbols on the product label

Symbol	Explanation
	DC voltage
	<p><b>RECYCLING</b></p> <p>This product bears the selective sorting symbol for Waste electrical and electronic equipment (WEEE). This means that this product must be handled pursuant to European directive 2012/19/EU in order to be recycled or dismantled to minimize its impact on the environment.</p> <p>User has the choice to give his product to a competent recycling organization or to the retailer when he buys a new electrical or electronic equipment.</p>

## DECLARATION OF CONFORMITY

For the following equipment:

Product Description: 300Mbps Wi-Fi Pocket Router/AP/TV Adapter/Repeater

Model No.: TL-WR810N

Trademark: **TP-LINK**

We declare under our own responsibility that the above products satisfy all the technical regulations applicable to the product within the scope of Council Directives:

Directives 1999/5/EC, Directives 2004/108/EC, Directives 2006/95/EC, Directives 1999/519/EC, Directives 2011/65/EU

The above product is in conformity with the following standards or other normative documents

**EN 300 328 V1.8.1**

**EN 301 489-1 V1.9.2 & EN 301 489-17 V2.2.1**

**EN 55022: 2010 + AC: 2011**

**EN 55024: 2010**

**EN 60950-1: 2006 + A11: 2009 + A1: 2010 + A12: 2011 +A2: 2013**

**EN 50385: 2002**

*The product carries the CE Mark:*

**CE 1588**

Person responsible for making this declaration:



**Yang Hongliang**

**Product Manager of International Business**

Date of issue: 2016.01.01

TP-LINK TECHNOLOGIES CO., LTD.

Building 24 (floors 1, 3, 4, 5), and 28 (floors 1-4) Central Science and Technology Park,  
Shennan Rd, Nanshan, Shenzhen, China



# CONTENTS

<b>Package Contents</b> .....	<b>1</b>
<b>Chapter 1. Introduction</b> .....	<b>2</b>
1.1 Overview of the Router .....	2
1.2 Conventions .....	3
1.3 Main Features .....	3
1.4 Panel Layout .....	3
<b>Chapter 2. Connecting the Router</b> .....	<b>5</b>
2.1 System Requirements.....	5
2.2 Installation Environment Requirements .....	5
2.3 Connecting the Router .....	5
2.3.1 Standard Wireless Router Mode.....	5
2.3.2 Access Point Mode .....	6
2.3.3 Repeater Mode .....	7
2.3.4 Client Mode.....	8
<b>Chapter 3. Quick Installation Guide</b> .....	<b>9</b>
3.1 TCP/IP Configuration .....	9
3.2 Quick Installation Guide .....	11
3.2.1 Standard Wireless Router Mode.....	13
3.2.2 Access Point Mode .....	17
3.2.3 Repeater Mode .....	19
3.2.4 Client Mode.....	22
<b>Chapter 4. Configuration for Standard Wireless Router Mode</b> .....	<b>25</b>
4.1 Login .....	25
4.2 Status .....	25
4.3 Quick Setup.....	27
4.4 WPS .....	27
4.5 Working Mode .....	31
4.6 Network .....	32
4.6.1 WAN.....	32
4.6.2 MAC Clone .....	41
4.6.3 LAN.....	42
4.7 Wireless .....	43

4.7.1	Wireless Settings .....	43
4.7.2	Wireless Security .....	44
4.7.3	Wireless MAC Filtering .....	47
4.7.4	Wireless Advanced .....	49
4.7.5	Wireless Statistics .....	50
4.8	DHCP .....	51
4.8.1	DHCP Settings .....	51
4.8.2	DHCP Client List .....	52
4.8.3	Address Reservation .....	53
4.9	USB Settings .....	54
4.9.1	Storage Sharing .....	54
4.9.2	FTP Server .....	56
4.9.3	Media Server .....	57
4.9.4	User Accounts .....	59
4.10	Forwarding .....	60
4.10.1	Virtual Servers .....	60
4.10.2	Port Triggering .....	62
4.10.3	DMZ .....	64
4.10.4	UPnP .....	64
4.11	Security .....	65
4.11.1	Basic Security .....	65
4.11.2	Advanced Security .....	67
4.11.3	Local Management .....	68
4.11.4	Remote Management .....	69
4.12	Parental Control .....	70
4.13	Access Control .....	72
4.13.1	Rule .....	73
4.13.2	Host .....	75
4.13.3	Target .....	76
4.13.4	Schedule .....	78
4.14	Advanced Routing .....	80

4.14.1	Static Routing List .....	80
4.14.2	System Routing Table.....	81
4.15	Bandwidth Control.....	82
4.15.1	Control Settings .....	82
4.15.2	Rule List.....	83
4.16	IP & MAC Binding .....	84
4.16.1	Binding Setting .....	84
4.16.2	ARP List.....	86
4.17	Dynamic DNS.....	87
4.17.1	No-IP DDNS .....	87
4.17.2	Comexe DDNS .....	88
4.17.3	Dyndns DDNS .....	88
4.18	System Tools.....	89
4.18.1	Time Settings.....	90
4.18.2	Diagnostic.....	91
4.18.3	Firmware Upgrade.....	92
4.18.4	Factory Defaults.....	93
4.18.5	Backup & Restore.....	93
4.18.6	Reboot .....	94
4.18.7	Password.....	95
4.18.8	System Log.....	95
4.18.9	Statistics.....	96
<b>Chapter 5.</b>	<b>Configuration for Access Point Mode .....</b>	<b>97</b>
5.1	Login .....	97
5.2	Status .....	97
5.3	Quick Setup.....	99
5.4	WPS.....	99
5.5	Working Mode .....	103
5.6	Network .....	104
5.6.1	LAN.....	104
5.7	Wireless .....	105
5.7.1	Wireless Settings.....	105

5.7.2	Wireless Security .....	107
5.7.3	Wireless MAC Filtering .....	109
5.7.4	Wireless Advanced .....	111
5.7.5	Wireless Statistics .....	112
5.7.6	Throughput Monitor .....	113
5.8	DHCP .....	114
5.8.1	DHCP Settings .....	114
5.8.2	DHCP Client List .....	115
5.8.3	Address Reservation .....	116
5.9	USB Settings .....	117
5.9.1	Storage Sharing .....	117
5.9.2	FTP Server .....	119
5.9.3	Media Server .....	121
5.9.4	User Accounts .....	122
5.10	System Tools .....	124
5.10.1	Diagnostic .....	124
5.10.2	Ping Watch Dog .....	126
5.10.3	Firmware Upgrade .....	127
5.10.4	Factory Defaults .....	127
5.10.5	Backup & Restore .....	128
5.10.6	Reboot .....	129
5.10.7	Password .....	129
5.10.8	System Log .....	130
<b>Chapter 6.</b>	<b>Configuration for Repeater Mode .....</b>	<b>131</b>
6.1	Login .....	131
6.2	Status .....	131
6.3	Quick Setup .....	133
6.4	Network .....	133
6.4.1	LAN .....	133
6.5	Wireless .....	134
6.5.1	Wireless Settings .....	134
6.5.2	Wireless Security .....	136

6.5.3	Wireless MAC Filtering .....	139
6.5.4	Wireless Advanced .....	141
6.5.5	Wireless Statistics .....	142
6.5.6	Throughput Monitor .....	143
6.6	DHCP .....	143
6.6.1	DHCP Settings.....	143
6.6.2	DHCP Client List.....	145
6.6.3	Address Reservation .....	145
6.7	USB Settings.....	147
6.7.1	Storage Sharing.....	147
6.7.2	FTP Server .....	148
6.7.3	Media Server .....	150
6.7.4	User Accounts.....	152
6.8	System Tools .....	153
6.8.1	Diagnostic .....	154
6.8.2	Ping Watch Dog.....	155
6.8.3	Firmware Upgrade .....	156
6.8.4	Factory Defaults.....	157
6.8.5	Backup & Restore.....	157
6.8.6	Reboot .....	158
6.8.7	Password.....	158
6.8.8	System Log.....	159
<b>Chapter 7.</b>	<b>Configuration for Client Mode .....</b>	<b>160</b>
7.1	Login .....	160
7.2	Status .....	160
7.3	Quick Setup.....	162
7.4	Network .....	162
7.4.1	LAN.....	162
7.5	Wireless .....	163
7.5.1	Wireless Settings.....	163
7.5.2	Wireless Security .....	165
7.5.3	Wireless MAC Filtering .....	167

7.5.4	Wireless Advanced .....	169
7.5.5	Wireless Statistics.....	170
7.5.6	Throughput Monitor .....	171
7.6	DHCP .....	171
7.6.1	DHCP Settings.....	172
7.6.2	DHCP Client List.....	173
7.6.3	Address Reservation .....	174
7.7	USB Settings.....	175
7.7.1	Storage Sharing.....	175
7.7.2	FTP Server .....	177
7.7.3	Media Server .....	178
7.7.4	User Accounts.....	180
7.8	System Tools.....	181
7.8.1	Diagnostic.....	181
7.8.2	Ping Watch Dog.....	183
7.8.3	Firmware Upgrade.....	184
7.8.4	Factory Defaults.....	185
7.8.5	Backup & Restore.....	185
7.8.6	Reboot .....	186
7.8.7	Password.....	186
7.8.8	System Log.....	187
<b>Appendix A: FAQ .....</b>		<b>188</b>
<b>Appendix B: Configuring the PC .....</b>		<b>193</b>
<b>Appendix C: Specifications .....</b>		<b>196</b>
<b>Appendix D: Glossary .....</b>		<b>197</b>

## Package Contents

The following items should be found in your package:

- One TL-WR810N 300Mbps Wi-Fi Pocket Router/AP/TV Adapter/Repeater
- Quick Installation Guide
- One RJ-45 Ethernet Cable

 **Note:**

Make sure that the package contains the above items. If any of the listed items is damaged or missing, please contact with your distributor. The provided power plug may differ from the picture due to different regional power specifications. Here we take the EU version as an example.

## Chapter 1. Introduction

### 1.1 Overview of the Router

Small enough to fit in the average pocket, the TL-WR810N 300Mbps Wi-Fi Pocket Router/AP/TV Adapter/Repeater is uniquely suited to provide robust wireless networking to travelers, students, or anyone else for work or play.

#### Incredible Speed

TL-WR810N supports the newest 802.11n standards, and provides backward compatibility with older 802.11b/g standards as well. The up-to-150Mbps wireless speed makes it ideal for handling multiple data streams at the same time, which ensures your network stable and smooth.

#### Multiple Operation Modes

The TL-WR810N 300Mbps Wi-Fi Pocket Router/AP/TV Adapter/Repeater supports five operation modes. Standard Wireless Router mode creates an instant private wireless network and share Internet to multiple Wi-Fi devices, which is suitable for most hotel and home network. Access Point mode creates a wireless network for Wi-Fi devices. The wireless devices are exposed to the wired network. Repeater mode extends your home wireless range by copying the same wireless name and password. Client mode works as a wireless adapter for any Ethernet-enabled devices, such as Smart TV, Game Console and PC.

#### Reliable Security Protections

With multiple protection measures, including SSID broadcast control and wireless LAN 64/128/152-bit WEP encryption, Wi-Fi protected Access (WPA2-PSK, WPA-PSK), as well as advanced Firewall protections, the TL-WR810N 300Mbps Wi-Fi Pocket Router/AP/TV Adapter/Repeater provides complete data privacy.

#### Flexible Access Control

The TL-WR810N 300Mbps Wi-Fi Pocket Router/AP/TV Adapter/Repeater supports Virtual Server and DMZ host for Port Triggering, and then the network administrators can manage and monitor the network in real time with the remote management function.

Since the Router is compatible with virtually all the major operating systems, it is very easy to manage. Quick Setup Wizard is supported and detailed instructions are provided step by step in



this user guide. Before installing the Router, please look through this guide to know all the Router's functions.

## 1.2 Conventions

The Router or TL-WR810N mentioned in this guide stands for TL-WR810N 300Mbps Wi-Fi Pocket Router/AP/TV Adapter/Repeater without any explanation.

Parameters provided in the pictures are just references for setting up the product, which may differ from the actual situation.

You can set the parameters according to your demand.

## 1.3 Main Features

- Portable design, ideal for travel and home use
- Built-in power supply design without external power adapter
- Support Standard Wireless Router, Access Point, Repeater, Client modes
- USB port supports charging for smart phone and tablet
- USB port supports storage sharing, media server function
- Pre-encryption prevents unauthorized access from users outside of the network

## 1.4 Panel Layout

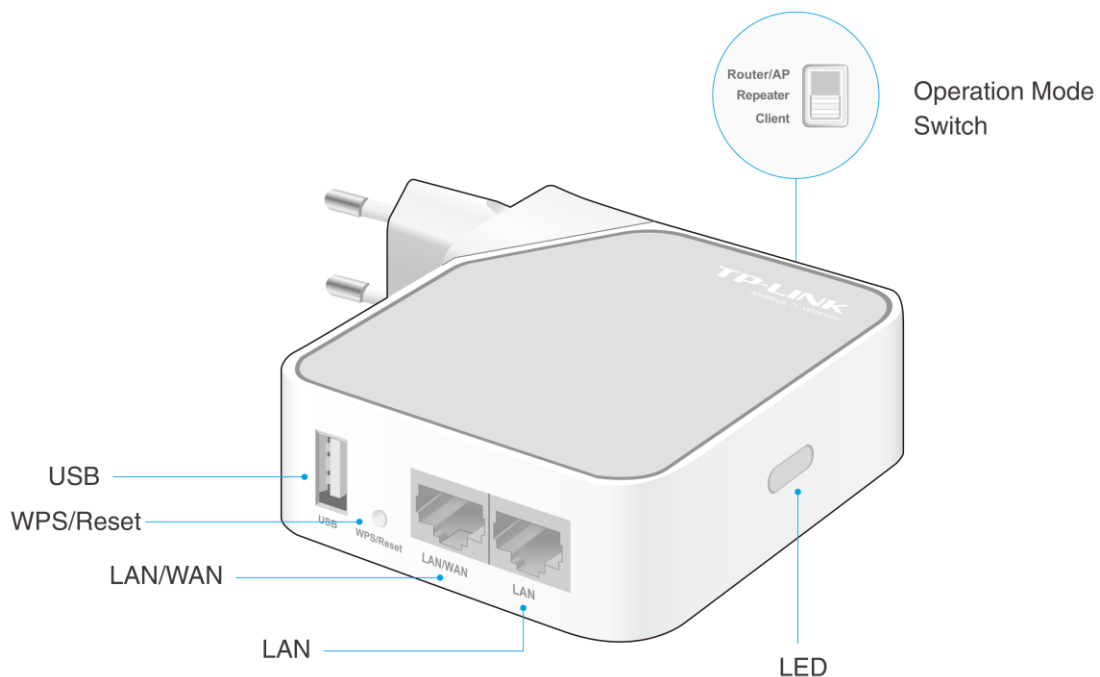

Figure 1-1 TL-WR810N sketch

➤ **LED**

Status	Indication
Solid	The device is working properly.
Blinking	Condition 1: System is booting. Condition 2: The Ethernet Cable or USB Device is connecting to the product.

Table 1-1 The LED Description

- **USB:** Connects a USB storage device for sharing or connects a mobile device to charge.
- **WPS/Reset:** Press this button to connect devices via the WPS (Wireless Protected Setup) method. Press and hold for 5 seconds to restore the router to its factory default settings. Refer to the FAQ section for instruction.
- **LAN/WAN:** Functions as the LAN port in Access Point, Repeater and Client mode. Functions as the WAN port in Standard Wireless Router mode.
- **LAN:** Connects an Ethernet-enabled device to the local network.
- **Operation Mode Switch:** Select your Internet mode.

## Chapter 2. Connecting the Router

### 2.1 System Requirements

- Each PC in the LAN needs a working Ethernet Adapter
- TCP/IP protocol must be installed on each PC
- Web browser, such as Microsoft Internet Explorer 5.0 or later, Mozilla Firefox, Apple Safari
- If the device is configured to Wireless Router/Access Point mode, you also need Broadband Internet Access Service (DSL/Cable/Ethernet)
- One DSL/Cable Modem that has an RJ45 connector (which is not necessary if the Router is connected directly to the Ethernet.)

### 2.2 Installation Environment Requirements

- Place the Router in a well-ventilated place far from any heater or heating vent
- Place the Router in a location where it can be connected to the various devices as well as to a power source
- Avoid direct irradiation of any strong light (such as sunlight)
- Keep at least 2 inches (5 cm) of clear space around the Router
- Operating Temperature: 0°C ~ 40°C (32°F ~104°F )
- Operating Humidity: 10%~90%RH, Non-condensing

### 2.3 Connecting the Router

Before installing the Router, please make sure your broadband service provided by your ISP is available. If there is any problem, please contact with your ISP. To connect the router, locate an optimum location for the Router. The best place is usually at the center of your wireless network. The place must accord with the [Installation Environment Requirements](#).

After finishing the steps above, please choose the operation mode you need and carry out the corresponding steps. There are four operation modes supported by this router: **Standard Wireless Router**, **Access Point**, **Repeater**, and **Client**.

#### 2.3.1 Standard Wireless Router Mode

Create an instant private wireless network and share Internet to multiple Wi-Fi devices. This mode is suitable for hotel rooms and home networks. (Note: if the hotel's Internet has an authentication process, you will need to authenticate only once and only on one device.)

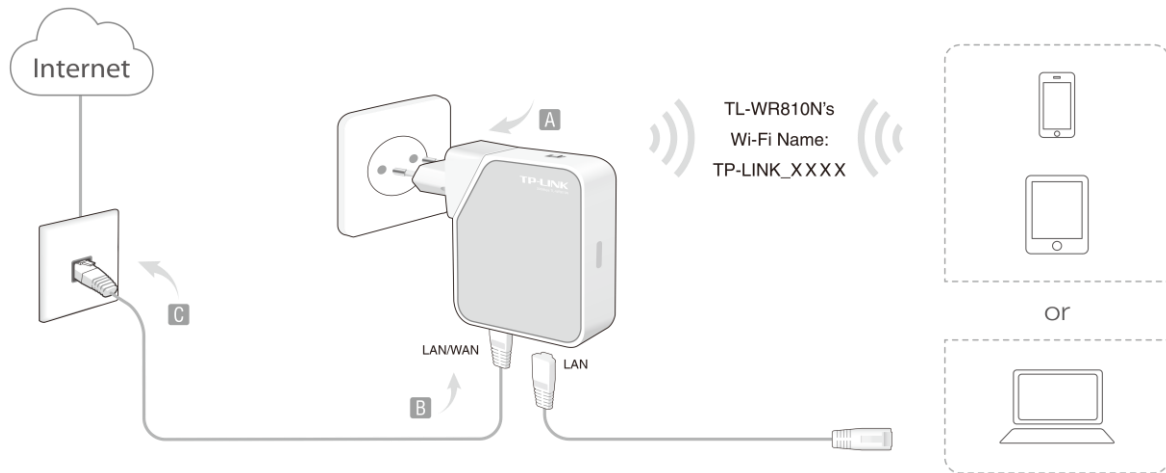

Figure 2-1 Hardware Installation of the TL-WR810N in Standard Wireless Router Mode

1. Set the Operation Mode Switch to **Router/AP**.
2. Power off your Cable/DSL Modem.
3. Connect the LAN/WAN port of TL-WR810N to the LAN Port on the DSL/Cable Modem.
4. Connect the WAN port on the DSL/Cable Modem to the wired Internet.
5. Plug the power plug of TL-WR810N in electrical wall socket. The Router will start to work automatically.
6. Power on the DSL/Cable Modem.
7. Connect your device to the router wirelessly or via an Ethernet cable. The Wi-Fi network name and password are on the router's label.

### 2.3.2 Access Point Mode

Create a wireless network from an Ethernet connection. This mode is suitable for dorm rooms or homes where there's already a wired router but you need a wireless hotspot. (Note: if the hotel's Internet has an authentication process, you will need to authenticate it on EACH device.)

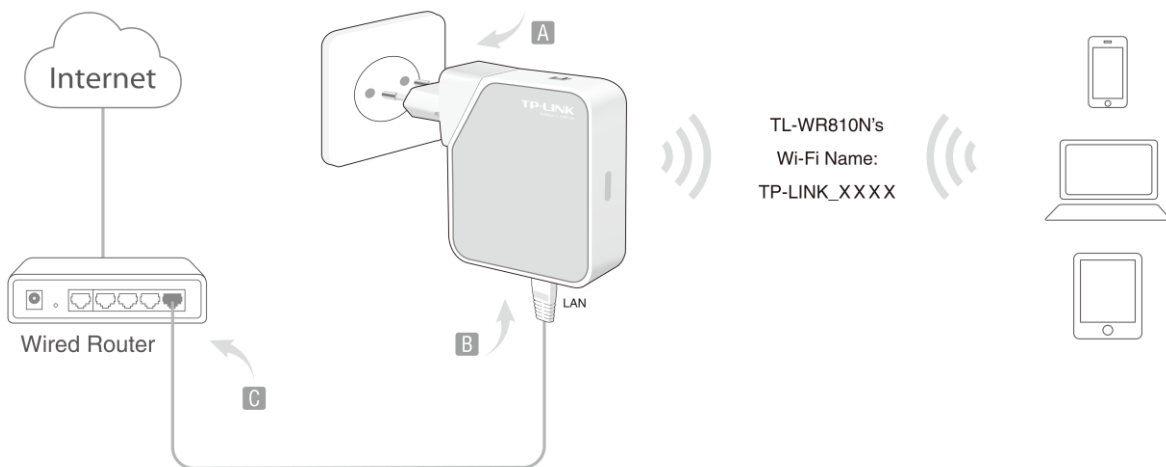

Figure 2-2 Hardware Installation of the TL-WR810N in Access Point Mode

1. Set the Operation Mode Switch to **Router/AP**.
2. Connect the LAN port of TL-WR810N to the LAN Port on the DSL/Cable Modem.
3. Plug the power plug of TL-WR810N in electrical wall socket. The Router will start to work automatically.
4. Connect your device to the router wirelessly. The Wi-Fi network name and password are on the router's label.

### 2.3.3 Repeater Mode

Repeat signal from an existing wireless network. This mode is suitable to extend wireless coverage, reaching devices that were previously too far from your primary router to maintain a stable wireless connection. The repeated signal will display the same network name and password as your existing wireless network.

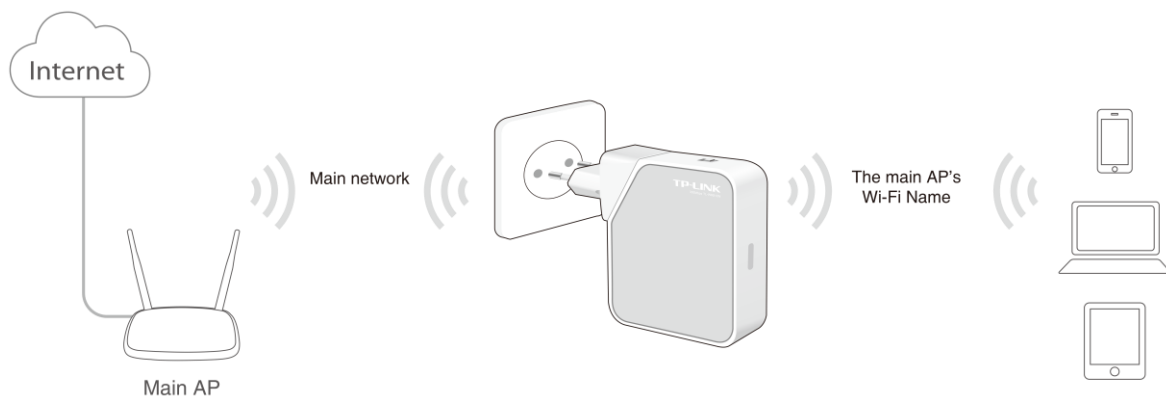

Figure 2-3 Hardware Installation of the TL-WR810N in Repeater Mode

1. Set the Operation Mode Switch to **Repeater**.
2. Plug the router into an electrical outlet within the signal range of your main AP.
3. Connect your device to the router wirelessly. The Wi-Fi network name and password are on the router's label.

#### **Note:**

It is recommended that you connect a PC/notebook to the LAN port of the Router with an Ethernet cable, and then login the Router from the PC/notebook to set the Router in Repeater mode.

### 2.3.4 Client Mode

In this mode, this device can be connected to another device via Ethernet cable and act as an adapter to grant your wired devices access to a wireless network, especially for a Smart TV, Media Player, or Game console only with an Ethernet port.

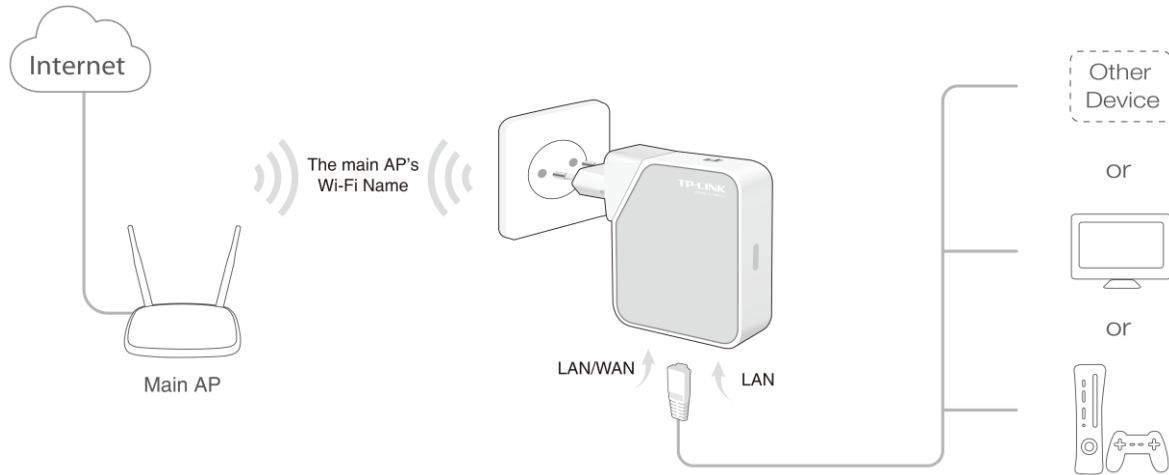

Figure 2-4 Hardware Installation of the TL-WR810N in Client Mode

1. Set the Operation Mode Switch to **Client**.
2. Plug the router into an electrical outlet within the signal range of your main AP.
3. Connect your device to the router wirelessly or via an Ethernet cable. The Wi-Fi network name and password are on the router's label.

## Chapter 3. Quick Installation Guide

This chapter will show you how to configure the basic functions of your TL-WR810N 300Mbps Wi-Fi Pocket Router/AP/TV Adapter/Repeater using **Quick Setup** within minutes.

### 3.1 TCP/IP Configuration

The default domain name of the TL-WR810N 300Mbps Wi-Fi Pocket Router/AP/TV Adapter/Repeater is <http://tplinkwifi.net>, the default IP address is 192.168.0.254, and the default Subnet Mask is 255.255.255.0. These values can be changed as you desire. In this guide, we use all the default values for description.

Connect the local PC to the LAN port of the Router. And then you can configure the IP address for your PC as the following steps:

- 1) Set up the TCP/IP Protocol in "**Obtain an IP address automatically**" mode on your PC. If you need instructions as to how to do this, please refer to [Appendix B: Configuring the PC](#).
- 2) Then the built-in DHCP server will assign IP address for the PC.

Then connect to the Router through wireless connection following the steps below:

- 1) Click the icon  at the bottom of your desktop. Click refresh button, and then select the default SSID of the Router. Click **Connect**.

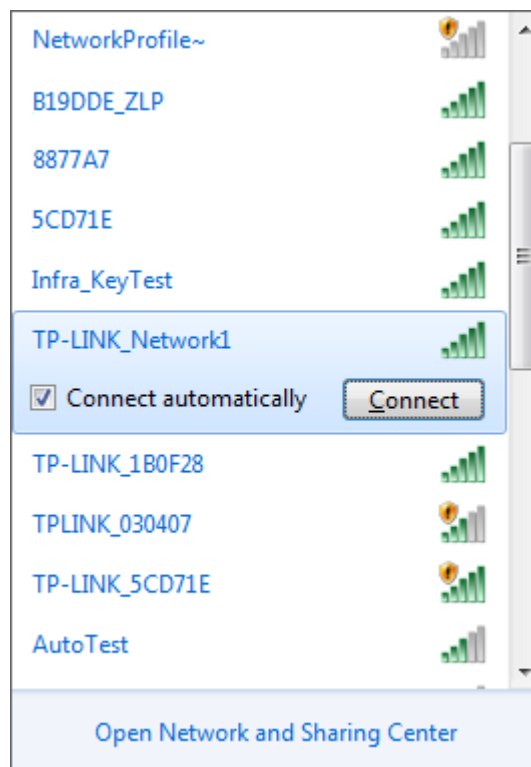

- 2) Enter the **Security key**. Click **OK**.

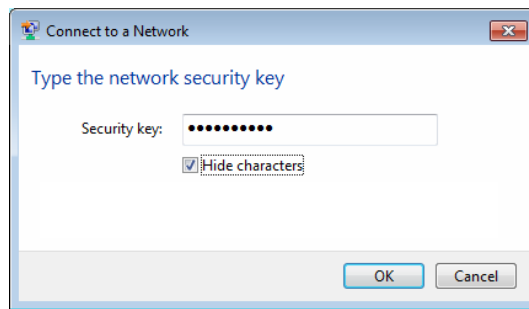

- 3) If you can see **Connected** after the default SSID, you've successfully connected to the wireless network.



**Note:**

1. The default **SSID** and **Password** of your Router are on the label. Both are case-sensitive.
2. The pre-encryption function is enabled by default and the default **Network key/Security key** is the **Password** on the label.

Now, you can run the Ping command in the **command prompt** to verify the network connection between your PC and the Router. The following example is in Windows XP.

Open a command prompt, and type *ping 192.168.0.254*, and then press **Enter**.

- If the result displayed is similar to the Figure 3-1, it means the connection between your PC and the Router has been established well.



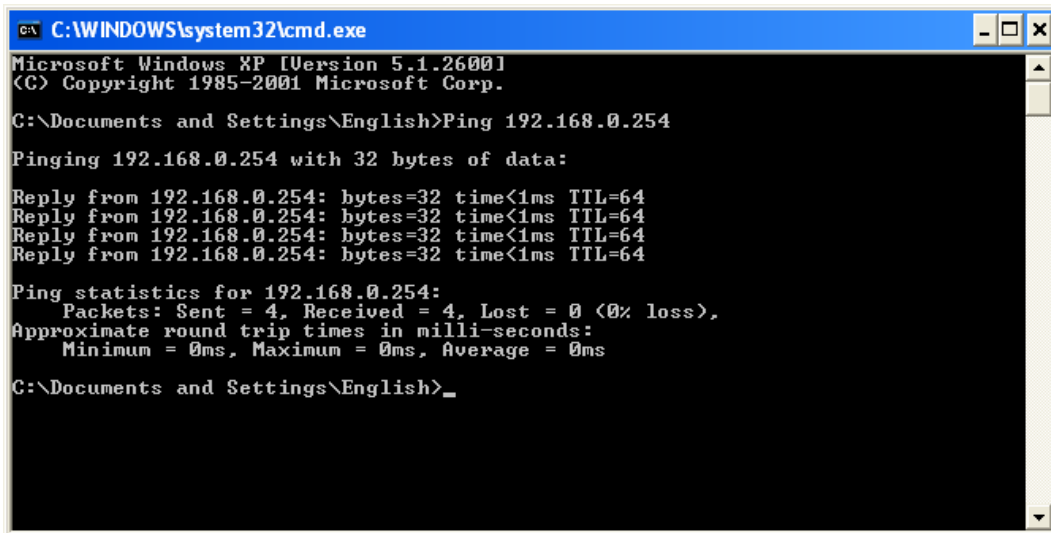

```
C:\WINDOWS\system32\cmd.exe
Microsoft Windows XP [Version 5.1.2600]
(C) Copyright 1985-2001 Microsoft Corp.

C:\Documents and Settings\English>Ping 192.168.0.254

Pinging 192.168.0.254 with 32 bytes of data:

Reply from 192.168.0.254: bytes=32 time<1ms TTL=64
Reply from 192.168.0.254: bytes=32 time<1ms TTL=64
Reply from 192.168.0.254: bytes=32 time<1ms TTL=64
Reply from 192.168.0.254: bytes=32 time<1ms TTL=64

Ping statistics for 192.168.0.254:
    Packets: Sent = 4, Received = 4, Lost = 0 (0% loss),
    Approximate round trip times in milli-seconds:
        Minimum = 0ms, Maximum = 0ms, Average = 0ms

C:\Documents and Settings\English>_
```

Figure 3-1 Success result of Ping command

- If the result displayed is similar to the Figure 3-2, it means the connection between your PC and the Router has failed.

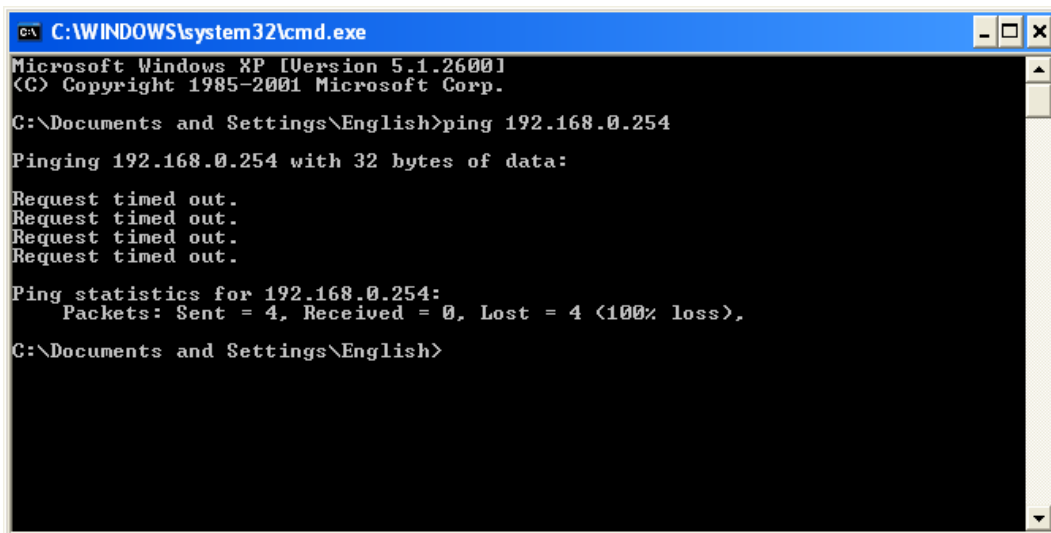

```
C:\WINDOWS\system32\cmd.exe
Microsoft Windows XP [Version 5.1.2600]
(C) Copyright 1985-2001 Microsoft Corp.

C:\Documents and Settings\English>ping 192.168.0.254

Pinging 192.168.0.254 with 32 bytes of data:

Request timed out.
Request timed out.
Request timed out.
Request timed out.

Ping statistics for 192.168.0.254:
    Packets: Sent = 4, Received = 0, Lost = 4 (100% loss),

C:\Documents and Settings\English>
```

Figure 3-2 Failure result of Ping command

**Please check the connection following these steps:**

1. Is the connection between your PC and the Router correct?
2. Is the TCP/IP configuration for your PC correct?

 **Note:**

If the Router's IP address is 192.168.0.254, your PC's IP address must be within the range of 192.168.0.1 ~ 192.168.0.253.

## 3.2 Quick Installation Guide

With a Web-based utility, it is easy to configure and manage the TL-WR810N 300Mbps Wi-Fi Pocket Router/AP/TV Adapter/Repeater. The Web-based utility can be used on any Windows,

Macintosh or UNIX OS with a Web browser, such as Microsoft Internet Explorer, Mozilla Firefox or Apple Safari.

1. To access the configuration utility, open a web-browser and type in the default address **http://tplinkwifi.net** in the address field of the browser.

After a moment, a login window will appear, similar to the Figure 3-3. Enter **admin** for the User Name and Password, both in lower case letters. Then click the **Login** button or press the **Enter** key.

A screenshot of a login window. It features two input fields: the top one contains the text 'admin' and has a person icon on the left; the bottom one contains five dots and has a key icon on the left. Below the fields is a green button with the text 'Login' in white.

Figure 3-3 Login Windows

 **Note:**

If the above screen does not pop-up, it means that your Web-browser has been set to a proxy. Go to Tools menu > Internet Options > Connections > LAN Settings, in the screen that appears, cancel the Using Proxy checkbox, and click **OK** to finish it.

2. After a successful login, you can click the **Quick Setup** menu to quickly configure your Router.

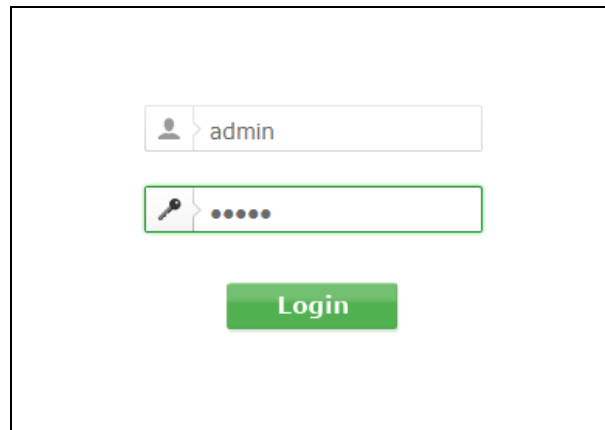
A screenshot of the 'Quick Setup' window. The title bar is green with the text 'Quick Setup'. Below the title bar, there is a large white area containing the text: 'Run the Quick Setup to manually configure your internet connection and wireless settings. To continue, please click the Next button. To exit, please click the Exit button.' At the bottom of the window, there are two buttons: 'Exit' and 'Next'.

Figure 3-4 Quick Setup

 **Note:**

The Router supports four working modes for multi-user to access the Internet: **Standard Wireless Router**, **Access Point**, **Repeater**, and **Client**. In **Standard Wireless Router** mode, the device enables multiple users to share the Internet connection via ADSL/Cable Modem. In **Access Point** mode, this device can be connected to a wired network and transform the wired access into wireless that multiple devices can share together. In **Repeater** mode, the device will relay data to an associated main AP. In **Client** mode, the device will act as a wireless station to enable wired

host(s) to access AP. You can configure your device quickly by the following steps in different modes.

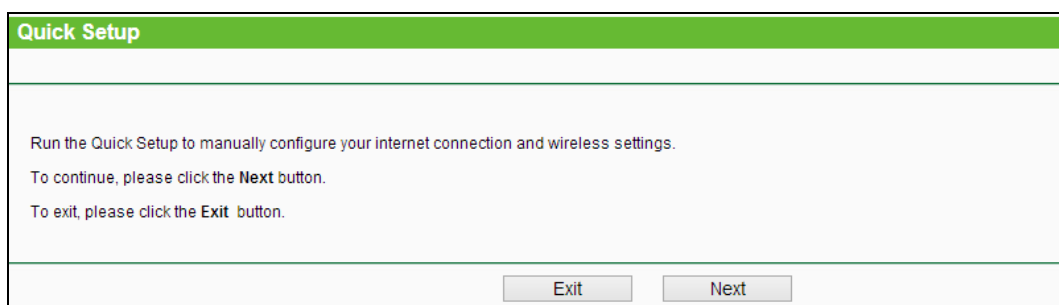
### 3.2.1 Standard Wireless Router Mode

When you set the operation mode switch to **Router/AP**, take the following steps:

1. Select **Standard Wireless Router** mode and click **Next**.
2. **WAN Connection Type** page will appear as shown in Figure 3-5.

**Quick Setup - WAN Connection Type**

The Quick Setup is preparing to set up your internet connection, please choose one type below according to your ISP. The detailed description will be displayed after you choose the corresponding type.

- Auto-Detect
- Dynamic IP (Most Common Cases)
- Static IP
- PPPoE/Russian PPPoE
- L2TP/Russian L2TP
- PPTP/Russian PPTP

Note: For users in some areas (such as Russia, Ukraine etc.), please contact your ISP to choose connection type manually.

Back Next

Figure 3-5 Quick Setup - WAN Connection Type

The Router provides **Auto-Detect** function and supports five popular ways **Dynamic IP**, **Static IP**, **PPPoE/Russia PPPoE**, **L2TP/Russia L2TP** and **PPTP/Russia PPTP** to connect to the Internet. If you are sure of what kind of connection type your ISP provides, you can select the very type and click **Next** to go on configuring. If you are not sure of what kind of connection type your ISP provides, you can select **Auto-Detect** and click **Next** to go on configuring.

#### Note:

**Auto-Detect** function is not suitable for **L2TP/Russia L2TP** and **PPTP/Russia PPTP**, you need to specify the connection type manually.

If you select **Auto-Detect**, the Router will automatically detect the connection type your ISP provides. Make sure the cable is securely plugged into the WAN port before detection. The appropriate configuration page will be displayed when an active Internet service is successfully detected by the Router. Then follow the instructions to complete the configuration.

- 1) If you select **Dynamic IP** manually, the next screen will appear as shown in Figure 3-6.
  - In most cases you don't need to clone the MAC address if you have rebooted the modem with the new router, please select **No, I do NOT need to clone MAC address**.
  - If you can't get the Internet connection after **Quick Setup**, please run it again and select **YES, I need to clone MAC address**.

Then click **Next** and Figure 3-11 will appear.

**Quick Setup - MAC Clone**

MAC(Media Access Control) address is a unique identifier that identifies your computer or device in the network. Some of the ISPs may register the MAC address of your computer which firstly connects to their services, and would not allow the Internet connection for any new computer or router.TP-LINK router can help you to "clone" or replicate the registered MAC address of your first computer.

In most of the cases, there is no need to clone the MAC address. But if you can't get the Internet connection after Quick Setup, please run it again and clone the MAC address for a try.

No, I do NOT need to clone MAC address.  
 YES, I need to clone MAC address.

Note: please make sure your current computer is the one initially connected to your modem or ISP's device.

Back Next

Figure 3-6 Quick Setup - MAC-Clone

- 2) If you select **Static IP** manually, the next screen will appear as shown in Figure 3-7. This type of connection uses a permanent, fixed (static) IP address that your ISP assigned. In this type, you should fill in the IP address, Subnet Mask, Default Gateway, and DNS IP address manually, which are specified by your ISP. Then click **Next** and proceed to Figure 3-11.

**Quick Setup - Static IP**

IP Address: 0.0.0.0

Subnet Mask: 0.0.0.0

Default Gateway: 0.0.0.0

Primary DNS: 0.0.0.0

Secondary DNS: 0.0.0.0 (Optional)

Back Next

Figure 3-7 Quick Setup - Static IP

- 3) If you select **PPPoE/Russia PPPoE** manually, the next screen will appear as shown in Figure 3-8.

**Quick Setup - PPPoE**

User Name: [ ]

Password: [ ]

Confirm Password: [ ]

Secondary Connection:  Disabled  Dynamic IP  Static IP (For Dual Access/Russia PPPoE)

Back Next

Figure 3-8 Quick Setup - PPPoE

- **User Name/Password** - Enter the **User Name** and **Password** provided by your ISP. These fields are case sensitive. If you have difficulty with this process, please contact your ISP.

- **Confirm Password** - Re-enter the password provided by your ISP to ensure the Password you entered is correct. If the Password is different from the Confirm Password, the screen will appear as shown below. Click **OK**, and re-enter the Password and Confirm Password.



- 4) If you select **L2TP/Russian L2TP** or **PPTP/Russian PPTP** manually, the next screen will appear as shown in Figure 3-9 and Figure 3-10.

Figure 3-9 Quick Setup - L2TP/Russian L2TP

Figure 3-10 Quick Setup - PPTP/Russian PPTP

- **User Name/Password** - Enter the **User Name** and **Password** provided by your ISP. These fields are case sensitive. If you have difficulty with this process, please contact your ISP.
- **Dynamic IP/Static IP** - Select **Static IP** if IP address, subnet mask, gateway and DNS server address have been provided by your ISP. Otherwise, please select **Dynamic IP**.

- **Server IP Address/Name** - Enter server IP address or domain name provided by your ISP.
3. Then, the **Wireless** page will appear as shown in Figure 3-11. Set the wireless parameters. It is recommended that you rename an SSID, choose a Security Type and enter a Password. Then click **Next**.

Figure 3-11 Quick Setup - Wireless

- **Wireless Radio** - Enable or disable the wireless radio choosing from the pull-down list.
- **Wireless Network Name** - Enter a string of up to 32 characters. The same name of SSID (Service Set Identification) must be assigned to all wireless devices in your network. The default SSID is set to be TP-LINK\_XXXX (XXXX indicates the last unique four numbers of each Router's MAC address). But it is recommended strongly that you change your networks name (SSID) to a different value. This value is case-sensitive. For example, *TEST* is NOT the same as *test*.
- **Region** - Select your region from the pull-down list. This field specifies the region where the wireless function of the Router can be used. It may be illegal to use the wireless function of the Router in a region other than one of those specified in this field. If your country or region is not listed, please contact your local government agency for assistance.
- **Mode** - This field determines the wireless mode which the Router works on.
- **Channel Width** - Select any channel width from the drop-down list. The default setting is automatic, which can adjust the channel width for your clients automatically.
- **Channel** - This field determines which operating frequency will be used. The default channel is set to **Auto**, so the AP will choose the best channel automatically. It is not

necessary to change the wireless channel unless you notice interference problems with another nearby access point.

- **Disable Security** - The wireless security function can be enabled or disabled. If disabled, the wireless stations will be able to connect the Router without encryption. It is recommended strongly that you choose one of following options to enable security.
- **WPA-PSK/WPA2-PSK** - Select WPA based on pre-shared passphrase.
  - **PSK Password** - You can enter **ASCII** or **Hexadecimal** characters.

For **ASCII**, the key can be made up of any numbers 0 to 9 and any letters A to Z, the length should be between 8 and 63 characters.

For **Hexadecimal**, the key can be made up of any numbers 0 to 9 and letters A to F, the length should be between 8 and 64 characters.

Please also note the key is case sensitive, this means that upper and lower case keys will affect the outcome. It would also be a good idea to write down the key and all related wireless security settings.
- **No Change** - If you chose this option, wireless security configuration will not change!

These settings are only for basic wireless parameters. For advanced settings, please refer to [4.7 Wireless](#).

4. The **Finish** page is shown as Figure 3-12. Click the **Finish** button to make your wireless configuration take effect and finish the **Quick Setup**.

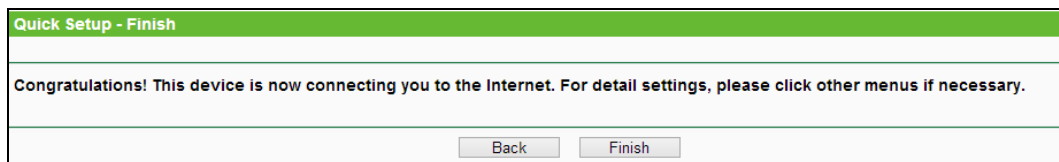

Figure 3-12 Quick Setup - Finish

### 3.2.2 Access Point Mode

When you set the operation mode switch to **Router/AP**, take the following steps:

1. Select **Access Point** mode and click **Next**.
2. The **Wireless Setting** page will appear as shown in Figure 3-13.

Working Mode	Operation Mode	Wireless Setting	Network Setting	Finish
<b>AP Mode Setting:</b>				
Wireless Network Name(SSID):	<input type="text" value="TP-LINK_0919"/> (also called SSID)			
Region:	<input type="text" value="United Kingdom"/>			
Warning:	Ensure you select a correct country to conform local law. Incorrect settings may cause interference.			
Channel:	<input type="text" value="Auto"/>			
Wireless Security Mode:	<input type="text" value="Most Secure(WPA/WPA2-PSK)"/>			
Wireless Password:	<input type="text" value="12345670"/>			
<small>You can enter ASCII or Hexadecimal characters. For Hexadecimal, the length should be between 8 and 64 characters; for ASCII, the length should be between 8 and 63 characters. For good security it should be of ample length and should not be a commonly known phrase.</small>				
		<input type="button" value="Back"/>	<input type="button" value="Next"/>	

Figure 3-13 Quick Setup - Wireless Setting

- **Wireless Network Name** - Enter a string of up to 32 characters. The same name of SSID (Service Set Identification) must be assigned to all wireless devices in your network. The default SSID is set to be TP-LINK\_XXXX (XXXX indicates the last unique four numbers of each Router's MAC address). But it is recommended strongly that you change your networks name (SSID) to a different value. This value is case-sensitive. For example, *TEST* is NOT the same as *test*.
  - **Region** - Select your region from the pull-down list. This field specifies the region where the wireless function of the Router can be used. It may be illegal to use the wireless function of the Router in a region other than one of those specified in this field. If your country or region is not listed, please contact your local government agency for assistance.
  - **Channel** - This field determines which operating frequency will be used. The default channel is set to **Auto**. It is not necessary to change the wireless channel unless you notice interference problems with another nearby access point.
  - **Wireless Security Mode** - This option should be chosen according to the security configuration of the AP you want to access. It is recommended that the security type is the same as your AP's security type.
  - **Wireless Password** - Input the password of your broadcast SSID.
3. Click the **Next** button. You will see the **Network Setting** page as shown in Figure 3-14. You can configure the IP parameters of LAN on this page.



Working Mode	Working Mode	Wireless Setting	Network Setting	Finish
<p>Type: <input type="text" value="Static IP"/></p> <p>Note: The IP parameters cannot be configured if you have chosen Smart IP (DHCP) (In this situation the device will help you configure the IP parameters automatically as you need).</p> <p>IP Address: <input type="text" value="192.168.0.254"/></p> <p>Subnet Mask: <input type="text" value="255.255.255.0"/></p> <p>We recommend you configure this AP with the same IP subnet and subnet mask, but different IP address from your root AP/Router.</p> <p>DHCP Server: <input checked="" type="radio"/> Disable <input type="radio"/> Enable</p> <p style="text-align: center;"> <input type="button" value="Back"/> <input type="button" value="Next"/> </p>				

Figure 3-14 Quick Setup - Network Setting

- **Type** - Select the LAN IP type of the router or you can set Smart IP as the default setting for most cases.
- **IP Address** - Enter the IP address of your system in dotted-decimal notation (factory default: 192.168.0.254).
- **Subnet Mask** - An address code that determines the size of the network. Normally 255.255.255.0 is used as the subnet mask.
- **DHCP Server** - Enable or Disable the server. If you disable the Server, you must have another DHCP server within your network or else you must configure the IP address of the computer manually.

 **Note:**

If you change the IP address, you must use the new IP address to login the system.

4. Click the Next button. You will see the **Finish** page as shown in Figure 3-15. Click the **Reboot** button to finish the Quick Setup.

Quick Setup - Finish
<p><b>Congratulations! This device is now connecting you to the Internet. For detail settings, please click other menus if necessary.</b></p> <p style="color: red;">The change of working mode config will not take effect until this device reboot.</p> <p style="text-align: center;"> <input type="button" value="Back"/> <input type="button" value="Reboot"/> </p>

Figure 3-15 Quick Setup - Finish

### 3.2.3 Repeater Mode

When you set the operation mode switch to **Repeater**, take the following steps:

1. Click **Next**, and then **Wireless Repeater** page will appear as shown in Figure 3-16.

Working Mode	Operation Mode	Wireless Setting	Network Setting	Finish
<b>Repeater Mode Setting:</b>				
Wireless Name of Root AP:		<input type="text"/>	(also called SSID)	
MAC Address of Root AP:		<input type="text"/>		
		<input type="button" value="Survey"/>		
You can click the Survey button to scan the network SSIDs, and then choose the target one to setup the connection.				
Region:		<input type="text" value="United Kingdom"/>		
Warning: Ensure you select a correct country to conform local law. Incorrect settings may cause interference.				
WDS Mode:		<input type="text"/>		
Wireless Security Mode:		<input type="text" value="Most Secure(WPA/WPA2-PSK)"/>		
All security settings, for example the wireless password should match the Root AP.				
Wireless Password:		<input type="text"/>		
You can enter ASCII or Hexadecimal characters. For Hexadecimal, the length should be between 8 and 64 characters; for ASCII, the length should be between 8 and 63 characters. For good security it should be of ample length and should not be a commonly known phrase.				
		<input type="button" value="Back"/>	<input type="button" value="Next"/>	

Figure 3-16 Quick Setup – Wireless Setting

- **Wireless Name of Root AP** - The SSID of AP that you want to access.
  - **MAC Address of Root AP** - The MAC address of AP that you want to access.
  - **Survey** - Click this button, you can search the AP which runs in the environment.
  - **Region** - Select your region from the pull-down list. This field specifies the region where the wireless function of the Router can be used. It may be illegal to use the wireless function of the Router in a region other than one of those specified in this field. If your country or region is not listed, please contact your local government agency for assistance.
  - **WDS Mode** - This field determines which WDS Mode will be used. It is not necessary to change the WDS Mode unless you notice network communication problems with root AP. If you select Auto, then Router will choose the appropriate WDS Mode automatically.
  - **Wireless Security Mode** - This option should be chosen according to the security configuration of the AP you want to access. It is recommended that the security type is the same as your AP's security type.
  - **Wireless Password** - If the AP your router is going to connect need password, you need to fill the password in this blank.
2. Click **Survey** button on the Wireless page as shown in Figure 3-16, and then AP List page will appear as shown in Figure 3-17. Find the SSID of the Access Point you want to access, and click **Connect** in the corresponding row. For example, the third item is selected. The target network's SSID will be automatically filled into the corresponding box which is shown as the Figure 3-16.

AP List						
AP Count: 16						
ID	BSSID	SSID	Signal	Channel	Security	Choose
1	6C-E8-73-CA-EE-68		68dB	4	None	<a href="#">Connect</a>
2	94-0C-6D-2F-3C-BE	TP-LINK_Network	47dB	4	WPA2-PSK	<a href="#">Connect</a>
3	84-1B-5E-D7-64-F2	TP-LINK_4234CC	31dB	1	WPA2-PSK	<a href="#">Connect</a>
4	4C-60-DE-32-63-8C	TP-LINK_18F710	30dB	11	WPA2-PSK	<a href="#">Connect</a>
5	6C-E8-73-CA-EE-6A	TP-LINK_D0A761	27dB	4	None	<a href="#">Connect</a>
6	14-E6-E4-E3-87-6A	TP-LINK_TEST	16dB	6	WPA2-PSK	<a href="#">Connect</a>

Back Refresh

Figure 3-17 AP List

 **Note:**

If you know the SSID of the desired AP, you can also input it into the field "SSID" manually.

3. Click the **Next** button. You will see the **Network Setting** page as shown in Figure 3-18. You can configure the IP parameters of LAN on this page.

Working Mode	Working Mode	Wireless Setting	Network Setting	Finish
<p>Type: <input type="text" value="Smart IP(DHCP)"/></p> <p><small>Note: The IP parameters cannot be configured if you have chosen Smart IP (DHCP) (In this situation the device will help you configure the IP parameters automatically as you need).</small></p> <p>IP Address: <input type="text" value="192.168.0.254"/></p> <p>Subnet Mask: <input type="text" value="255.255.255.0"/></p> <p><small>We recommend you configure this AP with the same IP subnet and subnet mask, but different IP address from your root AP/Router.</small></p> <p>DHCP Server: <input checked="" type="radio"/> Disable <input type="radio"/> Enable</p> <p>Back Next</p>				

Figure 3-18 Quick Setup - Network Setting

- **Type** - Select the LAN IP type of the router or you can set **Smart IP** as the default setting for most cases.
- **IP Address** - Enter the IP address of your system in dotted-decimal notation (factory default: 192.168.0.254).
- **Subnet Mask** - An address code that determines the size of the network. Normally 255.255.255.0 is used as the subnet mask.
- **DHCP Server** - Enable or Disable the server. If you disable the Server, you must have another DHCP server within your network or else you must configure the IP address of the computer manually.

 **Note:**

If you change the IP address, you must use the new IP address to login the system.

4. Click the **Next** button. You will see the **Finish** page as shown in Figure 3-19. Click the **Finish** button to make your wireless configuration take effect and finish the Quick Setup.

Figure 3-19 Quick Setup - Finish

### 3.2.4 Client Mode

When you set the operation mode switch to **Client**, take the following steps:

1. The **Wireless Setting** page will appear as shown in Figure 3-20.

Figure 3-20 Quick Setup - Wireless

- **Wireless Name of Root AP** - Enter the SSID that you want to access.
  - **MAC Address of Root AP** - Enter the MAC address of AP that you want to access.
  - **Survey** - Click this button, you can survey the AP which runs in the environment.
  - **Region** - Select your region from the pull-down list. This field specifies the region where the wireless function of the Router can be used. It may be illegal to use the wireless function of the Router in a region other than one of those specified in this field. If your country or region is not listed, please contact your local government agency for assistance.
  - **Wireless Security Mode** - This option should be chosen according to the security configuration of the AP you want to access. It is recommended that the security type is the same as your AP's security type.
  - **Wireless Password** - If the AP your router is going to connect need password, you need to fill the password in this blank.
2. Click **Survey** button on the Wireless page as shown in Figure 3-20, and then AP List page will appear as shown in Figure 3-21. Find the SSID of the Access Point you want to access, and

click **Connect** in the corresponding row. For example, the third item is selected. The target network's SSID will be automatically filled into the corresponding box which is shown as the Figure 3-20.

AP List						
AP Count: 16						
ID	BSSID	SSID	Signal	Channel	Security	Choose
1	6C-E8-73-CA-EE-68		68dB	4	None	<a href="#">Connect</a>
2	94-0C-6D-2F-3C-BE	TP-LINK_Network	47dB	4	WPA2-PSK	<a href="#">Connect</a>
3	84-1B-5E-D7-64-F2	TP-LINK_4234CC	31dB	1	WPA2-PSK	<a href="#">Connect</a>
4	4C-60-DE-32-63-8C	TP-LINK_18F710	30dB	11	WPA2-PSK	<a href="#">Connect</a>
5	6C-E8-73-CA-EE-6A	TP-LINK_D0A761	27dB	4	None	<a href="#">Connect</a>
6	14-E6-E4-E3-87-6A	TP-LINK_TEST	16dB	6	WPA2-PSK	<a href="#">Connect</a>

Back Refresh

Figure 3-21 AP List

- Click the **Next** button. You will see the **Network Setting** page as shown in Figure 3-22. You can configure the IP parameters of LAN on this page.

Working Mode	Working Mode	Wireless Setting	Network Setting	Finish
<p>Type: <input type="text" value="Smart IP(DHCP)"/> <small>Note: The IP parameters cannot be configured if you have chosen Smart IP (DHCP) (In this situation the device will help you configure the IP parameters automatically as you need).</small></p> <p>IP Address: <input type="text" value="192.168.0.254"/></p> <p>Subnet Mask: <input type="text" value="255.255.255.0"/> <small>We recommend you configure this AP with the same IP subnet and subnet mask, but different IP address from your root AP/Router.</small></p> <p>DHCP Server: <input checked="" type="radio"/> Disable <input type="radio"/> Enable</p> <p>Back Next</p>				

Figure 3-22 Quick Setup - Network Setting

- **Type** - Select the LAN IP type of the router or you can set **Smart IP** as the default setting for most cases.
- **IP Address** - Enter the IP address of your system in dotted-decimal notation (factory default: 192.168.0.254).
- **Subnet Mask** - An address code that determines the size of the network. Normally 255.255.255.0 is used as the subnet mask.
- **DHCP Server** - Enable or Disable the server. If you disable the Server, you must have another DHCP server within your network or else you must configure the IP address of the computer manually.

 **Note:**

If you change the IP address, you must use the new IP address to login the system.

4. Click the **Next** button. You will then see the **Finish** page. Click the **Finish** button to finish the Quick Setup.

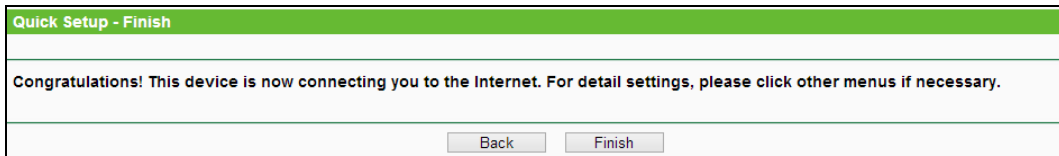

Figure 3-23 Quick Setup - Finish

 **Note:**

The operating distance or range of your wireless connection varies significantly based on the physical placement of the Router. For best results, place your Router.

- Near the center of the area in which your wireless stations will operate.
- In an elevated location such as a high shelf.
- Away from the potential sources of interference, such as PCs, microwaves, and cordless phones.
- Away from large metal surfaces.

Failure to follow these guidelines can result in significant performance degradation or inability to wirelessly connect to the Router.

## Chapter 4. Configuration for Standard Wireless Router Mode

This chapter will show each Web page's key functions and the configuration way for Wireless Router Mode of TL-WR810N.

### 4.1 Login

After your successful login, you can configure and manage the device. There are main menus on the left of the web-based utility. Submenus will be available after you click one of the main menus. On the right, there are the corresponding explanations and instructions.



Status
Quick Setup
WPS
Working Mode
Network
Wireless
DHCP
USB Settings
Forwarding
Security
Parental Control
Access Control
Advanced Routing
Bandwidth Control
IP & MAC Binding
Dynamic DNS
System Tools
Logout

Figure 4-1

The detailed explanations for each Web page's key function are listed below.

### 4.2 Status

The Status page provides the current status information about the Router on Wireless Router Mode. All information is read-only.

Status		
Firmware Version:	3.10.0 Build 150919 Rel.43473n	
Hardware Version:	TL-WR810N v1 00000000	
<b>LAN</b>		
MAC Address:	00-0A-EB-13-09-19	
IP Address:	192.168.0.254	
Subnet Mask:	255.255.255.0	
<b>Wireless</b>		
Wireless Radio:	Enable	
Name (SSID):	TP-LINK_0919	
Mode:	11bgn mixed	
Channel Width:	Automatic	
Channel:	Auto (Current channel 11)	
MAC Address:	00-0A-EB-13-09-19	
<b>WAN</b>		
MAC Address:	00-0A-EB-13-09-1A	
IP Address:	0.0.0.0	Dynamic IP
Subnet Mask:	0.0.0.0	
Default Gateway:	0.0.0.0	
DNS Server:	0.0.0.0, 0.0.0.0	
<b>WAN port is unplugged!</b>		
<b>Traffic Statistics</b>		
	Received	Sent
Bytes:	0	0
Packets:	0	0
System Up Time:	0 days 00:02:38	
	<input type="button" value="Refresh"/>	

Figure 4-2

- **Firmware Version** - The version information of the Router's firmware.
- **Hardware Version** - The version information of the Router's hardware.
- **LAN** - This field displays the current settings or information for the LAN, you can configure them in the **Network > LAN** page.
  - **MAC Address** - The physical address of the Router, as seen from the LAN.
  - **IP Address** - The LAN IP address of the Router.
  - **Subnet Mask** - The subnet mask associated with LAN IP address.
- **Wireless** - This field displays basic information or status for wireless function, you can configure them in the **Wireless > Wireless Settings** page.
  - **Wireless Radio** - Indicates whether the wireless radio feature of the AP is enabled or disabled.



- **Name (SSID)** - The SSID of the AP.
  - **Mode** - The current wireless mode which the Router works on.
  - **Channel Width** - The current wireless channel width in use.
  - **Channel** - The current wireless channel in use.
  - **MAC Address** - The physical address of the Router, as seen from the WLAN.
- **WAN** - This field displays the current settings or information for the WAN, you can configure them in the **Network > WAN** page.
- **MAC Address** - The physical address of the WAN port, as seen from the Internet.
  - **IP Address** - The current WAN (Internet) IP Address. This field will be blank or 0.0.0.0 if the IP Address is assigned dynamically and there is no connection to the Internet.
  - **Subnet Mask** - The subnet mask associated with the WAN IP Address.
  - **Default Gateway** - The Gateway currently used by the Router is shown here. When you use **Dynamic IP** as the connection Internet type, the **Renew** button will be displayed here. Click the **Renew** Button to obtain new IP parameters dynamically from the ISP. And if you have got an IP address, **Release** button will be displayed here. Click the **Release** button to release the IP address the Router has obtained from the ISP.
  - **DNS Server** - The DNS (Domain Name System) server IP addresses currently used by the Router.
- **Traffic Statistics** - The Router's traffic statistics.
- **Received (Bytes)** - Traffic that counted in bytes has been received out from the WAN port.
  - **Received (Packets)** - Traffic that counted in packets has been received out from the WAN port.
  - **Sent (Bytes)** - Traffic that counted in bytes has been sent out from the WAN port.
  - **Sent (Packets)** - Traffic that counted in packets has been sent out from the WAN port.
- **System Up Time** - The length of the time since the Router was last powered on or reset.

Click the **Refresh** button to get the latest status and settings of the Router.

### 4.3 Quick Setup

Please refer to [Section 3.2: Quick Installation Guide](#).

### 4.4 WPS

**WPS (Wi-Fi Protected Setup)** can help you to quickly and securely connect to a network. This section will guide you to add a new wireless device to an existing network quickly by function. The WPS function is only available when the Operation Mode is set to Access Point. Select menu "**WPS**", you will see the next screen shown in Figure 4-3.

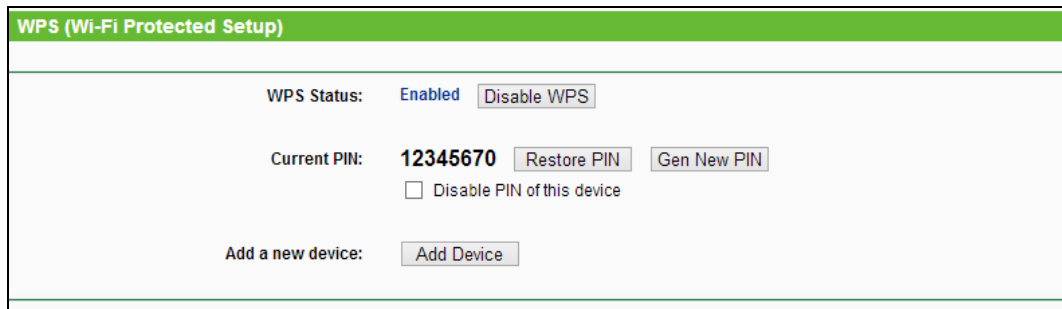

Figure 4-3 WPS

- **WPS Status** - To enable or disable the WPS function here.
- **Current PIN** - The current value of the device's PIN is displayed here. The default PIN of the device can be found in the label or User Guide.
- **Restore PIN** - Restore the PIN of the device to its default.
- **Gen New PIN** - Click this button, and then you can get a new random value for the device's PIN. You can ensure the network security by generating a new PIN.
- **Disable PIN of this Device** - WPS external registrar of entering the device's PIN can be disabled or enabled manually. If the device receives multiple failed attempts to authenticate an external Registrar, this function will be disabled automatically.
- **Add Device** - You can add a new device to the existing network manually by clicking this button.

#### To add a new device:

If the wireless adapter supports Wi-Fi Protected Setup (WPS), you can establish a wireless connection between wireless adapter and device using either Push Button Configuration (PBC) method or PIN method.

#### **Note:**

To build a successful connection by WPS, you should also do the corresponding configuration of the new device for WPS function meanwhile.

For the configuration of the new device, here takes the Wireless Adapter of our company for example.

#### I. By PBC

If the wireless adapter supports Wi-Fi Protected Setup and the Push Button Configuration (PBC) method, you can add it to the network by PBC with the following two methods.

##### Method One:

Step 1: Keep the WPS Status as **Enabled** and click the **Add Device** button in Figure 4-3, then the following screen will appear.

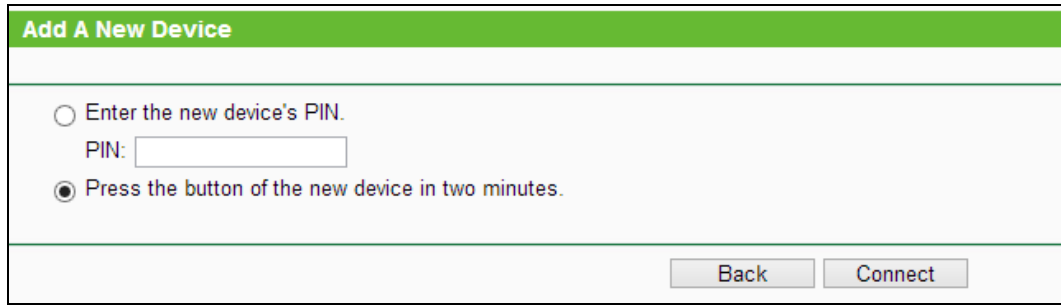

**Add A New Device**

Enter the new device's PIN.  
PIN:

Press the button of the new device in two minutes.

Figure 4-4 Add A New Device

Step 2: Choose “**Press the button of the new device in two minutes**” and click **Connect**.

Step 3: For the configuration of the wireless adapter, please choose “**Push the button on my access point or wireless router**” in the configuration utility of the WPS as below, and click **Connect**.

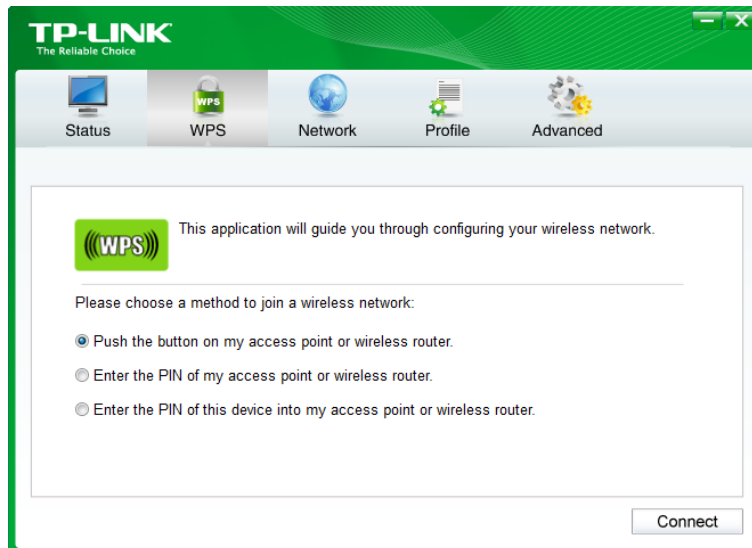

**TP-LINK**  
The Reliable Choice

Status WPS Network Profile Advanced

**WPS** This application will guide you through configuring your wireless network.

Please choose a method to join a wireless network:

Push the button on my access point or wireless router.

Enter the PIN of my access point or wireless router.

Enter the PIN of this device into my access point or wireless router.

The WPS Configuration Screen of Wireless Adapter

Step 4: Wait for a while until the next screen appears. Click **OK** to complete the WPS configuration.



Configuring the wireless network.

**WPS**

Successfully connected to the network by WPS!

The WPS Configuration Screen of Wireless Adapter

**Method Two:** Enter the PIN into my AP

Step 1: For the configuration of the wireless adapter, please choose “**Enter the PIN of this device into my access point or wireless router**” in the configuration utility of the WPS as below, and click **Connect**.



The WPS Configuration Screen of Wireless Adapter

**Note:**

In this example, the default PIN code of this adapter is 16952898 as the above figure shown.

Step 2: Keep the WPS Status as **Enabled** and click the **Add Device** button in Figure 4-3.

Step 3: Choose “**Enter the new device's PIN**” and enter the PIN code (take 16952898 for example) of the wireless adapter in the field after **PIN** as shown in the figure below. Then click **Connect**.

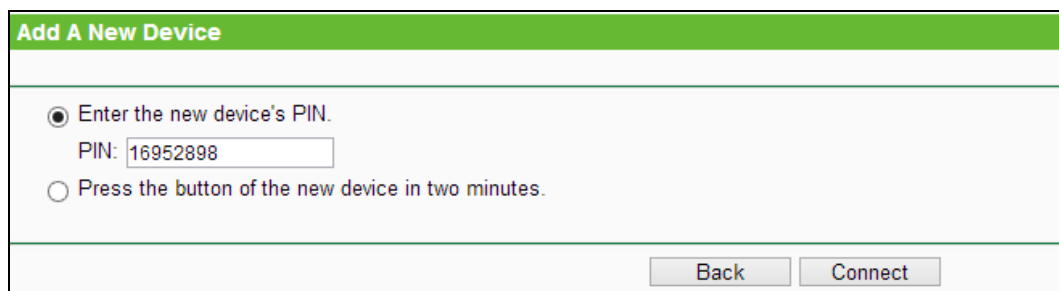

Figure 4-5 Add A New Device

**Method Three:** Enter the PIN from my AP

Step 1: Get the Current PIN code of the AP in Figure 4-3 (each AP has its unique PIN code. Here takes the PIN code 12345670 of this AP for example).

Step 2: For the configuration of the wireless adapter, please choose “**Enter the PIN of my access point or wireless router**” in the configuration utility of the WPS as below, and enter the PIN code of the AP into the field after “**Access Point PIN**”. Then click **Connect**.



The WPS Configuration Screen of Wireless Adapter

**Note:**

The default PIN code of the AP can be found in its label or the WPS configuration screen.

You will see the **Connect successfully** screen when the new device has successfully connected to the network.

**Note:**

- 1) The WPS LED on the AP will light green for five minutes if the device has been successfully added to the network.
- 2) The WPS function cannot be configured if the Wireless function of the AP is disabled. Please make sure the Wireless function is enabled before configuring the WPS.

## 4.5 Working Mode

Please select one you want. Click **Save** to save your choice, which is shown as Figure 4-6.

Working Mode	
<input checked="" type="radio"/> Standard Wireless Router	- Enable multiple users to share Internet connection via ADSL/Cable Modem
<input type="radio"/> Access Point	- Transform your existing wired network to a wireless network
<input type="button" value="Save"/>	

Figure 4-6 Working Mode Settings

- **Standard Wireless Router** - In this mode, the device enables multiple users to share the Internet connection via ADSL/Cable Modem. The LAN devices share the same IP from ISP through Wireless port. While connecting to Internet, the LAN/WAN Ethernet port works as a WAN port at Standard Wireless Router mode.

- **Access Point** - In this mode, this device can be connected to a wired network and transform the wired access into wireless that multiple devices can share together, especially for a home, office or hotel where only wired network is available.

## 4.6 Network

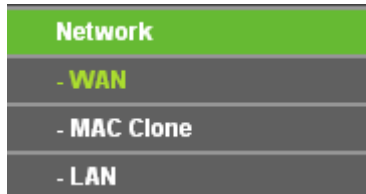

Figure 4-7 The Network menu

There are three submenus under the Network menu (shown in Figure 4-7): **WAN**, **MAC Clone** and **LAN**. Click any of them, and you will be able to configure the corresponding function.

### 4.6.1 WAN

Choose menu "**Network** → **WAN**", and then you can configure the IP parameters of the WAN on the screen below.

1. If your ISP provides the DHCP service, please choose **Dynamic IP** type, and the Router will automatically get IP parameters from your ISP. You can see the page as follow (Figure 4-8):

 A screenshot of the WAN configuration page. The page has a green header with the word 'WAN'. Below the header, there are several configuration fields:
 

- WAN Connection Type:** A dropdown menu set to 'Dynamic IP' with a 'Detect' button next to it.
- IP Address:** 192.168.1.104
- Subnet Mask:** 255.255.255.0
- Default Gateway:** 192.168.1.1
- Below the Default Gateway field are two buttons: 'Renew' and 'Release'.
- MTU Size (in bytes):** 1500 (The default is 1500, do not change unless necessary.)
- Use These DNS Servers
- Primary DNS:** 192.168.1.1
- Secondary DNS:** 0.0.0.0 (Optional)
- Host Name:** TL-WR810N
- Get IP with Unicast DHCP (It is usually not required.)
- At the bottom of the form is a 'Save' button.

Figure 4-8 WAN - Dynamic IP

This page displays the WAN IP parameters assigned dynamically by your ISP, including **IP address**, **Subnet Mask**, **Default Gateway**, etc. Click the **Renew** button to renew the IP parameters from your ISP. Click the **Release** button to release the IP parameters.

- **MTU Size** - The normal **MTU** (Maximum Transmission Unit) value for most Ethernet networks is 1500 Bytes. It is not recommended that you change the default **MTU Size** unless required by your ISP.
- **Use These DNS Servers** - If your ISP gives you one or two DNS addresses, select **Use These DNS Servers** and enter the primary and secondary addresses into the correct fields. Otherwise, the DNS servers will be assigned dynamically from your ISP.

 **Note:**

If you find error when you go to a website after entering the DNS addresses, it is likely that your DNS servers are set up improperly. You should contact your ISP to get DNS server addresses.

- **Host Name** - This option specifies the Host Name of the Router.
- **Get IP with Unicast DHCP** - A few ISPs' DHCP servers do not support the broadcast applications. If you cannot get the IP Address normally, you can choose this option. (It is rarely required.)

Click the **Save** button to save your settings.

2. If your ISP provides a static or fixed **IP Address**, **Subnet Mask**, **Default Gateway** and **DNS** setting, select **Static IP**. The Static IP settings page will appear as shown in Figure 4-9.

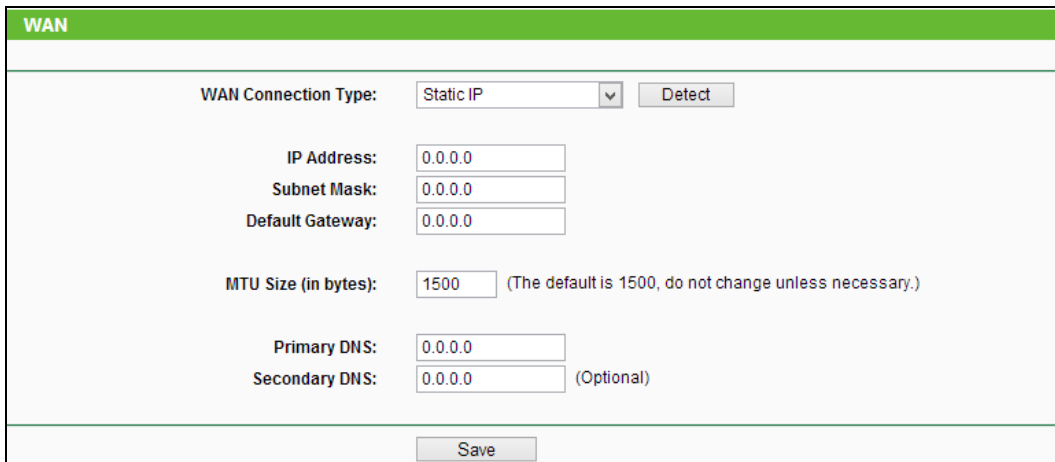

WAN	
WAN Connection Type:	Static IP <input type="button" value="Detect"/>
IP Address:	0.0.0.0
Subnet Mask:	0.0.0.0
Default Gateway:	0.0.0.0
MTU Size (in bytes):	1500 (The default is 1500, do not change unless necessary.)
Primary DNS:	0.0.0.0
Secondary DNS:	0.0.0.0 (Optional)
<input type="button" value="Save"/>	

Figure 4-9 WAN - Static IP

- **IP Address** - Enter the IP address in dotted-decimal notation provided by your ISP.
- **Subnet Mask** - Enter the subnet Mask in dotted-decimal notation provided by your ISP, usually is 255.255.255.0.
- **Default Gateway** - Enter the gateway IP address in dotted-decimal notation provided by your ISP.

- **MTU Size** - The normal **MTU** (Maximum Transmission Unit) value for most Ethernet networks is 1500 Bytes. It is not recommended that you change the default **MTU Size** unless required by your ISP.
- **Primary/Secondary DNS** - (Optional) Enter one or two DNS addresses in dotted-decimal notation provided by your ISP.

Click the **Save** button to save your settings.

3. If your ISP provides a PPPoE connection, select **PPPoE/Russia PPPoE** option. Then you should enter the following parameters (Figure 4-10):

The screenshot shows the WAN configuration interface. At the top, there is a green header with the text 'WAN'. Below this, the 'WAN Connection Type' is set to 'PPPoE/Russia PPPoE' with a dropdown arrow and a 'Detect' button. Under 'PPPoE Connection', there are three input fields: 'User Name' containing 'username', 'Password' with masked characters, and 'Confirm Password' also with masked characters. The 'Secondary Connection' section has three radio buttons: 'Disabled' (selected), 'Dynamic IP', and 'Static IP (For Dual Access/Russia PPPoE)'. The 'Wan Connection Mode' section has four radio buttons: 'Connect on Demand', 'Connect Automatically' (selected), 'Time-based Connecting', and 'Connect Manually'. Under 'Connect on Demand', there is a 'Max Idle Time' field set to '15' minutes. Under 'Time-based Connecting', there is a 'Period of Time' field set from '0 : 0 (HH:MM)' to '23 : 59 (HH:MM)'. Under 'Connect Manually', there is a 'Max Idle Time' field set to '15' minutes. At the bottom of the form, there are three buttons: 'Connect', 'Disconnect', and 'Disconnected!'. At the very bottom of the page, there are two buttons: 'Save' and 'Advanced'.

Figure 4-10 WAN - PPPoE/Russia PPPoE

- **User Name/Password** - Enter the User Name and Password provided by your ISP. These fields are case-sensitive.
- **Confirm Password** - Enter again the Password provided by your ISP to ensure the password you entered is correct.
- **Secondary Connection** - It's available only for PPPoE Connection. If your ISP provides an extra Connection type such as Dynamic/Static IP to connect to a local area network, then you can check the radio button of Dynamic/Static IP to activate this secondary connection.
  - **Disabled** - The Secondary Connection is disabled by default, so there is PPPoE connection only. This is recommended.
  - **Dynamic IP** - You can check this radio button to use Dynamic IP as the secondary connection to connect to the local area network provided by ISP.
  - **Static IP** - You can check this radio button to use Static IP as the secondary connection to connect to the local area network provided by ISP.



- **Connect on Demand** - In this mode, the Internet connection can be terminated automatically after a specified inactivity period (**Max Idle Time**) and be re-established when you attempt to access the Internet again. If you want your Internet connection keeps active all the time, please enter "0" in the **Max Idle Time** field. Otherwise, enter the number of minutes you want to have elapsed before your Internet access disconnects.
- **Connect Automatically** - The connection can be re-established automatically when it was down.
- **Time-based Connecting** - The connection will only be established in the period from the start time to the end time (both are in HH:MM format).

 **Note:**

Only when you have configured the system time on "**System Tools** → **Time**" page, will the **Time-based Connecting** function can take effect.

- **Connect Manually** - You can configure the router to make it connect or disconnect manually. After a specified period of inactivity (**Max Idle Time**), the router will disconnect from your Internet connection, and you will not be able to re-establish your connection automatically as soon as you attempt to access the Internet again. To use this option, check the radio button. If you want your Internet connection to remain active at all times, enter "0" in the **Max Idle Time** field. Otherwise, enter the number of minutes that you wish to have the Internet connecting last unless a new link is requested.

Click the **Connect** button to connect immediately. Click the **Disconnect** button to disconnect immediately.

**Caution:** Sometimes the connection cannot be terminated although you specify a time to Max Idle Time because some applications are visiting the Internet continually in the background.

If you want to do some advanced configurations, please click the **Advanced** button, and the page shown in Figure 4-11 will then appear:

Figure 4-11 WAN - PPPoE Advanced Settings

- **MTU Size** - The default MTU size is “1480” bytes, which is usually fine. It is not recommended that you change the default **MTU Size** unless required by your ISP.
- **Service Name/AC Name** - The service name and AC (Access Concentrator) name should not be configured unless you are sure it is necessary for your ISP. In most cases, leaving these fields blank will work.
- **ISP Specified IP Address** - If your ISP does not automatically assign IP addresses to the Router during login, please click “**Use IP address specified by ISP**” check box and enter the IP address provided by your ISP in dotted-decimal notation.
- **Detect Online Interval** - The Router will detect Access Concentrator online at every interval. The default value is “0”. You can input the value between “0” and “120”. The value “0” means no detect.
- **Primary DNS/Secondary DNS** - If your ISP does not automatically assign DNS addresses to the Router during login, please click “**Use the following DNS servers**” check box and enter the IP address in dotted-decimal notation of your ISP’s primary DNS server. If a secondary DNS server address is available, enter it as well.

Click the **Save** button to save your settings.

4. If your ISP provides BigPond Cable connection, please select **BigPond Cable** option. Then you should enter the following parameters (Figure 4-12):

The screenshot shows the WAN configuration interface for a BigPond Cable connection. The page has a green header with the word 'WAN'. Below the header, the configuration fields are as follows:

- WAN Connection Type:** A dropdown menu set to 'BigPond Cable'.
- User Name:** An empty text input field.
- Password:** An empty text input field.
- Auth Server:** A text input field containing 'sm-server'.
- Auth Domain:** An empty text input field.
- MTU Size (in bytes):** A text input field containing '1500', with a note: '(The default is 1500, do not change unless necessary.)'
- Connection Mode:** Three radio buttons: 'Connect on Demand', 'Connect Automatically' (which is selected), and 'Connect Manually'.
  - Under 'Connect on Demand', there is a 'Max Idle Time' field containing '15' minutes.
  - Under 'Connect Manually', there is a 'Max Idle Time' field containing '15' minutes.

At the bottom of the form, there are three buttons: 'Connect', 'Disconnect', and 'Disconnected!'. Below the entire form area is a 'Save' button.

Figure 4-12 WAN - BigPond Cable

- **User Name/Password** - Enter the User Name and Password provided by your ISP. These fields are case-sensitive.
- **Auth Server** - Enter the authenticating server IP address or host name.
- **Auth Domain** - Type in the domain suffix server name based on your location,
- **MTU Size** - The default MTU size is "1480" bytes, which is usually fine. It is not recommended that you change the default **MTU Size** unless required by your ISP.
- **Connect on Demand** - In this mode, the Internet connection can be terminated automatically after a specified inactivity period (**Max Idle Time**) and be re-established when you attempt to access the Internet again. If you want your Internet connection keeps active all the time, please enter "0" in the **Max Idle Time** field. Otherwise, enter the number of minutes you want to have elapsed before your Internet access disconnects.
- **Connect Automatically** - The connection can be re-established automatically when it was down.
- **Connect Manually** - You can configure the router to make it connect or disconnect manually. After a specified period of inactivity (**Max Idle Time**), the router will disconnect from your Internet connection, and you will not be able to re-establish your connection automatically as soon as you attempt to access the Internet again. To use this option, check the radio button. If you want your Internet connection to remain active at all times, enter "0" in the **Max Idle Time** field. Otherwise, enter the number of minutes that you wish to have the Internet connecting last unless a new link is requested.

Click the **Connect** button to connect immediately. Click the **Disconnect** button to disconnect immediately.

**Caution:** Sometimes the connection cannot be terminated although you specify a time to Max Idle Time because some applications are visiting the Internet continually in the background.

Click the **Save** button to save your settings.

- If your ISP provides L2TP connection, please select **L2TP/Russia L2TP** option. Then you should enter the following parameters (Figure 4-13):

The screenshot shows the WAN configuration interface for L2TP/Russia L2TP. The page has a green header with the word 'WAN'. The configuration fields are as follows:

- WAN Connection Type:** A dropdown menu set to 'L2TP/Russia L2TP'.
- User Name:** A text input field containing 'username'.
- Password:** A text input field with masked characters '\*\*\*\*\*'.
- Confirm Password:** A text input field with masked characters '\*\*\*\*\*'.
- Buttons:** 'Connect' (disabled), 'Disconnect' (disabled), and 'Disconnected!' (text).
- Dynamic IP / Static IP:** Radio buttons for 'Dynamic IP' (selected) and 'Static IP'.
- Server IP Address/Name:** A text input field.
- IP Address:** 0.0.0.0
- Subnet Mask:** 0.0.0.0
- Gateway:** 0.0.0.0
- DNS:** 0.0.0.0, 0.0.0.0
- Internet IP Address:** 0.0.0.0
- Internet DNS:** 0.0.0.0, 0.0.0.0
- MTU Size (in bytes):** 1460 (The default is 1460, do not change unless necessary.)
- Max Idle Time:** 15 minutes (0 means remain active at all times.)
- Connection Mode:** Radio buttons for 'Connect on Demand', 'Connect Automatically' (selected), and 'Connect Manually'.
- Save:** A button at the bottom of the form.

Figure 4-13 WAN - L2TP/Russia L2TP

- **User Name/Password** - Enter the User Name and Password provided by your ISP. These fields are case-sensitive.
- **Confirm Password** - Enter again the Password provided by your ISP to ensure the password you entered is correct.
- **Dynamic IP/ Static IP** - Choose either as you are given by your ISP. Click the **Connect** button to connect immediately. Click the **Disconnect** button to disconnect immediately.
- **Server IP Address/Name** - Enter server IP address or domain name provided by your ISP.
- **IP Address** - Enter the IP address used for dial-up. (Only can be configured when Static IP is selected)
- **Subnet Mask** - Enter the subnet mask provided by your ISP. (Only can be configured when Static IP is selected)

- **Gateway** - Enter gateway provided by your ISP. (Only can be configured when Static IP is selected)
- **DNS** - Enter DNS server provided by your ISP. (Only can be configured when Static IP is selected)
- **Internet IP Address** - The Internet IP address assigned by L2TP server.
- **Internet DNS** - The Internet DNS server address assigned by L2TP server.
- **Connect on Demand** - You can configure the Router to disconnect from your Internet connection after a specified period of inactivity (**Max Idle Time**). If your Internet connection has been terminated due to inactivity, **Connect on Demand** enables the Router to automatically re-establish your connection as soon as you attempt to access the Internet again. If you wish to activate **Connect on Demand**, check the radio button. If you want your Internet connection to remain active at all times, enter 0 in the **Max Idle Time** field. Otherwise, enter the number of minutes you want to have elapsed before your Internet connection terminates.
- **Connect Automatically** - Connect automatically after the Router is disconnected. To use this option, check the radio button.
- **Connect Manually** - You can configure the Router to make it connect or disconnect manually. After a specified period of inactivity (**Max Idle Time**), the Router will disconnect from your Internet connection, and you will not be able to re-establish your connection automatically as soon as you attempt to access the Internet again. To use this option, check the radio button. If you want your Internet connection to remain active at all times, enter "0" in the **Max Idle Time** field. Otherwise, enter the number of minutes that you wish to have the Internet connecting last unless a new link is requested.

**Caution:** Sometimes the connection cannot be disconnected although you specify a time to **Max Idle Time**, because some applications are visiting the Internet continually in the background.

Click the **Connect** button to connect immediately.

Click the **Disconnect** button to disconnect immediately.

Click the **Save** button to save your settings.

6. If your ISP provides PPTP connection, please select **PPTP/Russia PPTP** option. And you should enter the following parameters (Figure 4-14):

**WAN**

WAN Connection Type: PPTP/Russia PPTP

User Name: username

Password: \*\*\*\*\*

Confirm Password: \*\*\*\*\*

Connect Disconnect Disconnected!

Dynamic IP  Static IP

Server IP Address/Name: \_\_\_\_\_

IP Address: 0.0.0.0

Subnet Mask: 0.0.0.0

Gateway: 0.0.0.0

DNS: 0.0.0.0, 0.0.0.0

Internet IP Address: 0.0.0.0

Internet DNS: 0.0.0.0, 0.0.0.0

MTU Size (in bytes): 1420 (The default is 1420, do not change unless necessary.)

Max Idle Time: 15 minutes (0 means remain active at all times.)

Connection Mode:  Connect on Demand  Connect Automatically  Connect Manually

Save

Figure 4-14 WAN - PPTP/Russia PPTP

- **User Name/Password** - Enter the User Name and Password provided by your ISP. These fields are case-sensitive.
- **Confirm Password** - Enter again the Password provided by your ISP to ensure the password you entered is correct.
- **Dynamic IP/ Static IP** - Choose either as you are given by your ISP and enter the ISP's IP address or the domain name.
- **Server IP Address/Name** - Enter server IP address or domain name provided by your ISP.
- **IP Address** - Enter the IP address used for dial-up. (Only can be configured when Static IP is selected)
- **Subnet Mask** - Enter the subnet mask provided by your ISP. (Only can be configured when Static IP is selected)
- **Gateway** - Enter gateway provided by your ISP. (Only can be configured when Static IP is selected)
- **DNS** - Enter DNS server provided by your ISP. (Only can be configured when Static IP is selected)
- **Internet IP Address** - The Internet IP address assigned by PPTP server.
- **Internet DNS** - The Internet DNS server address assigned by PPTP server.

- **Connect on Demand** - You can configure the Router to disconnect from your Internet connection after a specified period of inactivity (**Max Idle Time**). If your Internet connection has been terminated due to inactivity, **Connect on Demand** enables the Router to automatically re-establish your connection as soon as you attempt to access the Internet again. If you wish to activate **Connect on Demand**, check the radio button. If you want your Internet connection to remain active at all times, enter "0" in the **Max Idle Time** field. Otherwise, enter the number of minutes you want to have elapsed before your Internet connection terminates.
- **Connect Automatically** - Connect automatically after the Router is disconnected. To use this option, check the radio button.
- **Connect Manually** - You can configure the Router to make it connect or disconnect manually. After a specified period of inactivity (**Max Idle Time**), the Router will disconnect from your Internet connection, and you will not be able to re-establish your connection automatically as soon as you attempt to access the Internet again. To use this option, click the radio button. If you want your Internet connection to remain active at all times, enter "0" in the **Max Idle Time** field. Otherwise, enter the number in minutes that you wish to have the Internet connecting last unless a new link is requested.

**Caution:** Sometimes the connection cannot be disconnected although you specify a time to **Max Idle Time** because some applications are visiting the Internet continually in the background.

Click the **Connect** button to connect immediately.

Click the **Disconnect** button to disconnect immediately.

Click the **Save** button to save your settings.

## 4.6.2 MAC Clone

Choose menu "**Network** → **MAC Clone**", and then you can configure the WAN MAC address on the screen below, as shown in Figure 4-15:

MAC Clone	
WAN MAC Address:	<input type="text" value="00-0A-EB-13-09-1A"/> <input type="button" value="Restore Factory MAC"/>
Your PC's MAC Address:	<input type="text" value="74-D4-35-9F-D3-7D"/> <input type="button" value="Clone MAC Address"/>
<input type="button" value="Save"/>	

Figure 4-15 MAC Address Clone

Some ISPs require that you register the MAC Address of your adapter. Changes are rarely needed here.

- **WAN MAC Address** - This field displays the current MAC address of the WAN port. If your ISP requires you to register the MAC address, please enter the correct MAC address into this field in XX-XX-XX-XX-XX-XX format (X is any hexadecimal digit).
- **Your PC's MAC Address** - This field displays the MAC address of the PC that is managing the Router. If the MAC address is required, you can click the **Clone MAC Address To** button and this MAC address will fill in the **WAN MAC Address** field.

Click **Restore Factory MAC** to restore the MAC address of WAN port to the factory default value.

Click the **Save** button to save your settings.

 **Note:**

1. Only the PC on your LAN can use the **MAC Address Clone** function.
2. If you change WAN MAC Address when the WAN connection is PPPoE, it will not take effect until the connection is re-established.

### 4.6.3 LAN

Choose menu "**Network** → **LAN**", and then you can configure the IP parameters of the LAN on the screen as below.

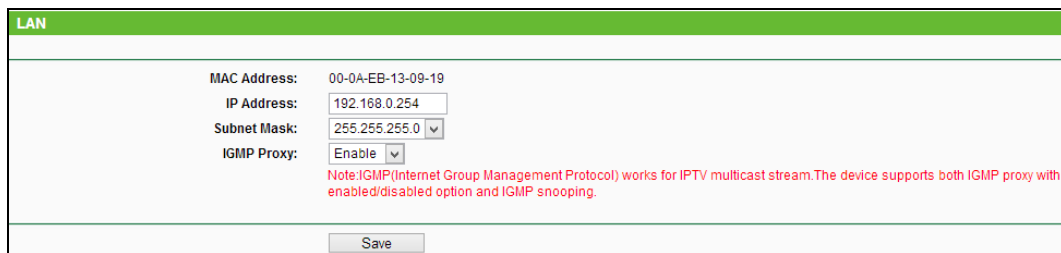

Figure 4-16 LAN

- **MAC Address** - The physical address of the LAN ports, as seen from the LAN. The value can't be changed.
- **IP Address** - Enter the IP address of your Router in dotted-decimal notation (factory default: 192.168.0.254).
- **Subnet Mask** - An address code that determines the size of the network. Normally use 255.255.255.0 as the subnet mask.
- **IGMP Proxy** - The Internet Group Management Protocol (IGMP) feature allows your devices in LAN can watch TV.

 **Note:**

1. If you change the IP Address of LAN, you must use the new IP Address to login to the Router.
2. If the new LAN IP Address you set is not in the same subnet with the previous one, the IP Address pool in the DHCP server will be configured automatically, while the Virtual Server and DMZ Host will not take effect until they are re-configured.



## 4.7 Wireless



Figure 4-17 Wireless menu

There are five submenus under the Wireless menu (shown in Figure 4-17): **Wireless Settings**, **Wireless Security**, **Wireless MAC Filtering**, **Wireless Advanced** and **Wireless Statistics**. Click any of them, and you will be able to configure the corresponding function.

### 4.7.1 Wireless Settings

Choose menu “**Wireless** → **Wireless Settings**”, and then you can configure the basic settings for the wireless network on this page.

A screenshot of the 'Wireless Settings' configuration page. The page has a green header with the title 'Wireless Settings'. Below the header, there are several configuration fields: 'Wireless Network Name' (text input with 'TP-LINK\_0919' and '(Also called the SSID)' in parentheses), 'Region' (dropdown menu with 'United Kingdom'), a 'Warning' message: 'Ensure you select a correct country to conform local law. Incorrect settings may cause interference.', 'Mode' (dropdown menu with '11bgn mixed'), 'Channel Width' (dropdown menu with 'Auto'), and 'Channel' (dropdown menu with 'Auto'). At the bottom, there are two checked checkboxes: 'Enable Wireless Router Radio' and 'Enable SSID Broadcast'. A 'Save' button is located at the very bottom of the form.

Figure 4-18 Wireless Settings - Router

- **Wireless Network Name** - Enter a string of up to 32 characters. The same name of SSID (Service Set Identification) must be assigned to all wireless devices in your network. The default SSID is set to be TP-LINK\_XXXX (XXXX indicates the last unique four numbers of each Router's MAC address). But it is recommended strongly that you change your networks name (SSID) to a different value. This value is case-sensitive. For example, *TEST* is NOT the same as *test*.
- **Region** - Select your region from the pull-down list. This field specifies the region where the wireless function of the Router can be used. It may be illegal to use the wireless function of the Router in a region other than one of those specified in this field. If your country or region is not listed, please contact your local government agency for assistance.
- **Mode** - Select the desired mode. The default setting is 11bgn mixed.

- **11bg mixed** - Select if you are using both 802.11b and 802.11g wireless clients.
- **11bgn mixed** - Select if you are using a mix of 802.11b, 11g, and 11n wireless clients.

When 11bg mixed mode is selected, only 11bg mixed wireless stations can connect to the Router. It is strongly recommended that you set the Mode to 11bgn mixed, and all of 802.11b/g/n wireless stations can connect to the Router.

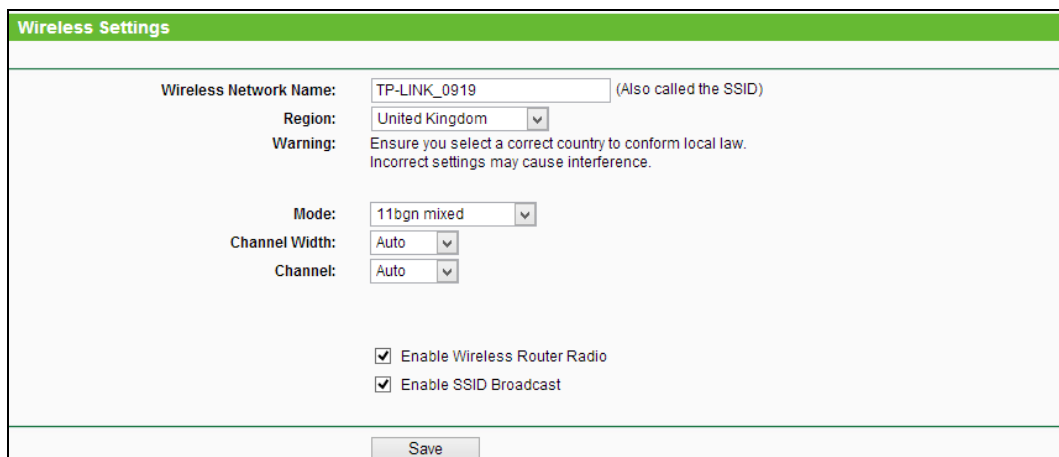
 **Note:**

If **11bg mixed mode** is selected in the **Mode** field, the **Channel Width** selecting field will turn grey and the value will become 20M, which is unable to be changed.

- **Channel Width** - Select any channel width from the pull-down list. The default setting is automatic, which can automatically adjust the channel width for your clients.
- **Channel** - This field determines which operating frequency will be used. The default channel is set to **Auto**. It is not necessary to change the wireless channel unless you notice interference problems with another nearby access point.
- **Enable Wireless Router Radio** - The wireless radio of the Router can be enabled or disabled to allow wireless stations access. If enabled, the wireless stations will be able to access the Router. Otherwise, wireless stations will not be able to access the Router.
- **Enable SSID Broadcast** - If you select the **Enable SSID Broadcast** checkbox, the wireless router will broadcast its name (SSID) on the air.

Be sure to click the **Save** button to save your settings on this page.

 **Note:**

1. The operating distance or range of your wireless connection varies significantly based on the physical placement of the Router. For best results, place your Router.
  - Near the center of the area in which your wireless stations will operate.
  - In an elevated location such as a high shelf.
  - Away from the potential sources of interference, such as PCs, microwaves, and cordless phones.
  - Away from large metal surfaces.
2. Failure to follow these guidelines can result in significant performance degradation or inability to wirelessly connect to the Router.

## 4.7.2 Wireless Security

Choose menu "**Wireless** → **Wireless Security**", and then you can configure the security settings of your wireless network.

There are three wireless security modes supported by the Router: WPA/WPA2-Personal, WPA/WPA2-Enterprise and WEP (Wired Equivalent Privacy).

Wireless Security

**Disable Security**

**WPA/WPA2 - Personal(Recommended)**

Version:

Encryption:

Wireless Password:

(You can enter ASCII characters between 8 and 63 or Hexadecimal characters between 8 and 64.)

Group Key Update Period:  Seconds

(Keep it default if you are not sure, minimum is 30, 0 means no update)

**WPA/WPA2 - Enterprise**

Version:

Encryption:

Radius Server IP:

Radius Port:  (1-65535, 0 stands for default port 1812)

Radius Password:

Group Key Update Period:  (in second, minimum is 30, 0 means no update)

**WEP**

Type:

WEP Key Format:

Key Selected	WEP Key	Key Type
Key 1: <input checked="" type="radio"/>	<input type="text"/>	<input type="text" value="Disabled"/>
Key 2: <input type="radio"/>	<input type="text"/>	<input type="text" value="Disabled"/>
Key 3: <input type="radio"/>	<input type="text"/>	<input type="text" value="Disabled"/>
Key 4: <input type="radio"/>	<input type="text"/>	<input type="text" value="Disabled"/>

Figure 4-19 Wireless Security

- **Disable Security** - The wireless security function can be enabled or disabled. If disabled, the wireless stations will be able to connect the Router without encryption. But it's strongly recommended to choose one of the following modes to enable security.
- **WPA-PSK/WPA2-Personal** - It's the WPA/WPA2 authentication type based on pre-shared passphrase.
  - **Version** - you can choose the version of the WPA-PSK security on the drop-down list. The default setting is **Automatic**, which can select **WPA-PSK** (Pre-shared key of WPA) or **WPA2-PSK** (Pre-shared key of WPA) automatically based on the wireless station's capability and request.
  - **Encryption** - When **WPA-PSK** or **WPA** is set as the Authentication Type, you can select either **Automatic**, or **TKIP** or **AES** as Encryption.
  - **Wireless Password** - You can enter ASCII or Hexadecimal characters. For Hexadecimal, the length should be between 8 and 64 characters; for ASCII, the length should be between 8 and 63 characters.
  - **Group Key Update Period** - Specify the group key update interval in seconds. The value can be either 0 or at least 30. Enter 0 to disable the update.

 **Note:**

If you check the **WPA-PSK/WPA2-PSK** radio button and choose TKIP encryption, you will find a notice in red as shown.

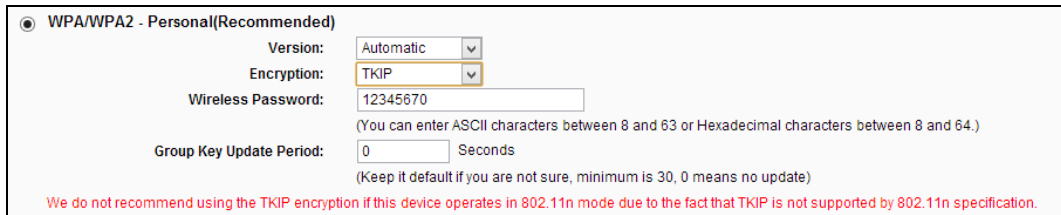

WPA/WPA2 - Personal(Recommended)  
 Version: Automatic  
 Encryption: TKIP  
 Wireless Password: 12345670  
(You can enter ASCII characters between 8 and 63 or Hexadecimal characters between 8 and 64.)  
 Group Key Update Period: 0 Seconds  
(Keep it default if you are not sure, minimum is 30, 0 means no update)  
**We do not recommend using the TKIP encryption if this device operates in 802.11n mode due to the fact that TKIP is not supported by 802.11n specification.**

➤ **WPA /WPA2-Enterprise** - It's based on Radius Server.

- **Version** - you can choose the version of the WPA security from the pull-down list. The default setting is **Automatic**, which can select **WPA** (Wi-Fi Protected Access) or **WPA2** (WPA version 2) automatically based on the wireless station's capability and request.
- **Encryption** - You can select **Automatic**, **TKIP** or **AES**.
- **Radius Server IP** - Enter the IP address of the Radius server.
- **Radius Port** - Enter the port that Radius server used.
- **Radius Password** - Enter the password for the Radius server.
- **Group Key Update Period** - Specify the group key update interval in seconds. The value should be 30 or above. Enter 0 to disable the update.

➤ **WEP** - It is based on the IEEE 802.11 standard.

- **Type** - you can choose the type for the WEP security on the pull-down list. The default setting is **Automatic**, which can select **Shared Key** or **Open System** authentication type automatically based on the wireless station's capability and request.
- **WEP Key Format** - **Hexadecimal** and **ASCII** formats are provided here. **Hexadecimal** format stands for any combination of hexadecimal digits (0-9, a-f, A-F) in the specified length. **ASCII** format stands for any combination of keyboard characters in the specified length.
- **WEP Key (Password)** - Select which of the four keys will be used and enter the matching WEP key that you create. Make sure these values are identical on all wireless stations in your network.
- **Key Type** - You can select the WEP key length (64-bit, or 128-bit, or 152-bit.) for encryption. "Disabled" means this WEP key entry is invalid.
  - 64-bit** - You can enter 10 hexadecimal digits (any combination of 0-9, a-f, A-F, and null key is not permitted) or 5 ASCII characters.
  - 128-bit** - You can enter 26 hexadecimal digits (any combination of 0-9, a-f, A-F, and null key is not permitted) or 13 ASCII characters.

**152-bit** - You can enter 32 hexadecimal digits (any combination of 0-9, a-f, A-F, and null key is not permitted) or 16 ASCII characters.

**Note:**

If you do not set the key, the wireless security function is still disabled even if you have selected Shared Key as Authentication Type.

Be sure to click the **Save** button to save your settings on this page.

### 4.7.3 Wireless MAC Filtering

Choose menu "**Wireless** → **Wireless MAC Filtering**", and then you can control the wireless access by configuring the **Wireless MAC Filtering** function.

Figure 4-20 Wireless MAC Filtering

To filter wireless users by MAC Address, click **Enable**. The default setting is **Disable**.

- **MAC Address** - The wireless station's MAC address that you want to access.
- **Status** - The status of this entry, either **Enabled** or **Disable**.
- **Description** - A simple description of the wireless station.

To Add a Wireless MAC Address filtering entry, click the **Add New...** button. The "**Add or Modify Wireless MAC Address Filtering entry**" page will appear, shown in Figure 4-21:

Figure 4-21 Add or Modify Wireless MAC Address Filtering entry

**To add or modify a MAC Address Filtering entry, follow these instructions:**

1. Enter the appropriate MAC Address into the **MAC Address** field. The format of the MAC Address is XX-XX-XX-XX-XX-XX (X is any hexadecimal digit). For example: 00-0A-EB-B0-00-0B.

2. Give a simple description for the wireless station in the **Description** field. For example: Wireless station A.
3. Select **Enabled** or **Disabled** for this entry on the **Status** pull-down list.
4. Click the **Save** button to save this entry.

**To modify an existing entry:**

1. Click the **Modify** in the entry you want to modify.
2. Modify the information.
3. Click the **Save** button.

Click the **Delete** in the entry you want to delete to delete an existing entry.

Click the **Enable All** button to make all entries enabled

Click the **Disable All** button to make all entries disabled.

Click the **Delete All** button to delete all entries.

Click the **Next** button to go to the next page.

Click the **Previous** button to return to the previous page.

**For example:** If you desire that the wireless station A with MAC address 00-0A-EB-B0-00-0B and the wireless station B with MAC address 00-0A-EB-00-07-5F are able to access the Router, but all the other wireless stations cannot access the Router, you can configure the **Wireless MAC Address Filtering** list by following these steps:

1. Click the **Enabled** button to enable this function.
2. Select the radio button "Allow the stations specified by any enabled entries in the list to access" for **Filtering Rules**.
3. Delete all or disable all entries if there are any entries already.
4. Click the **Add New...** button.
  - 1) Enter the MAC address 00-0A-EB-B0-00-0B/00-0A-EB-00-07-5F in the **MAC Address** field.
  - 2) Enter wireless station A/B in the **Description** field.
  - 3) Select **Enabled** in the **Status** pull-down list.
  - 4) Click the **Save** button.
  - 5) Click the **Back** button.

The filtering rules that configured should be similar to the following list:

**Filtering Rules**

Deny the stations specified by any enabled entries in the list to access.  
 Allow the stations specified by any enabled entries in the list to access.

ID	MAC Address	Status	Description	Modify
1	00-0A-EB-B0-00-0B	Enabled	wireless station A	<a href="#">Modify</a> <a href="#">Delete</a>
2	00-0A-EB-00-07-5F	Enabled	wireless station B	<a href="#">Modify</a> <a href="#">Delete</a>

#### 4.7.4 Wireless Advanced

Choose menu **“Wireless → Wireless Advanced”**, and then you can configure the advanced settings of your wireless network.

**Wireless Advanced**

Transmit Power: High ▼

Beacon Interval : 100 (40-1000)

RTS Threshold: 2346 (256-2346)

Fragmentation Threshold: 2346 (256-2346)

DTIM Interval: 1 (1-255)

Enable WMM  
 Enable Short GI  
 Enable AP Isolation

Save

Figure 4-22 Wireless Advanced

- **Transmit Power** - Here you can specify the transmit power of Router. You can select High, Middle or Low which you would like. High is the default setting and is recommended.
- **Beacon Interval** - Enter a value between 20-1000 milliseconds for Beacon Interval here. The beacons are the packets sent by the Router to synchronize a wireless network. Beacon Interval value determines the time interval of the beacons. The default value is 100.
- **RTS Threshold** - Here you can specify the RTS (Request to Send) Threshold. If the packet is larger than the specified RTS Threshold size, the Router will send RTS frames to a particular receiving station and negotiate the sending of a data frame. The default value is 2346.
- **Fragmentation Threshold** - This value is the maximum size determining whether packets will be fragmented. Setting the Fragmentation Threshold too low may result in poor network performance because of excessive packets. 2346 is the default setting and is recommended.
- **DTIM Interval** - This value determines the interval of the Delivery Traffic Indication Message (DTIM). A DTIM field is a countdown field informing clients of the next window for listening to broadcast and multicast messages. When the Router has buffered broadcast or multicast messages for associated clients, it sends the next DTIM with a DTIM Interval value. You can

specify the value between 1-255 Beacon Intervals. The default value is 1, which indicates the DTIM Interval is the same as Beacon Interval.

- **Enable WMM - WMM** function can guarantee the packets with high-priority messages being transmitted preferentially. It is strongly recommended enabled.
- **Enable Short GI** - This function is recommended for it will increase the data capacity by reducing the guard interval time.
- **Enable AP Isolation** - This function isolate all connected wireless stations so that wireless stations cannot access each other through WLAN. This function will be disabled if WDS/Bridge is enabled.

#### **Note:**

If you are not familiar with the setting items in this page, it's strongly recommended to keep the provided default values; otherwise it may result in lower wireless network performance.

### 4.7.5 Wireless Statistics

Choose menu “**Wireless** → **Wireless Statistics**”, and then you can see the MAC Address, Current Status, Received Packets and Sent Packets for each connected wireless station.

Wireless Statistics					
Current Connected Wireless Stations numbers: 1					<input type="button" value="Refresh"/>
ID	MAC Address	Current Status	Received Packets	Sent Packets	Configure
1	70-73-CB-1F-C8-C9	STA-ASSOC	46	16	<input type="button" value="Allow"/>

Figure 4-23 Wireless Statistics

- **MAC Address** - The connected wireless station's MAC address
- **Current Status** - The connected wireless station's running status, one of **STA-AUTH / STA-ASSOC / STA-JOINED / WPA / WPA-PSK / WPA2 / WPA2-PSK / AP-UP / AP-DOWN / Disconnected**
- **Received Packets** - Packets received by the station
- **Sent Packets** - Packets sent by the station.
- **Configure** - The button is used for loading the item to the **Wireless MAC Filtering** list.
  - **Allow** - If the **Wireless MAC Filtering** function enable, allow the station to access.
  - **Deny** - If the **Wireless MAC Filtering** function enable, deny the station to access.



You cannot change any of the values on this page. To update this page and to show the current connected wireless stations, click on the **Refresh** button.

If the numbers of connected wireless stations go beyond one page, click the **Next** button to go to the next page and click the **Previous** button to return the previous page.

 **Note:**

This page will be refreshed automatically every 5 seconds.

## 4.8 DHCP

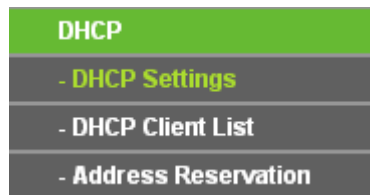
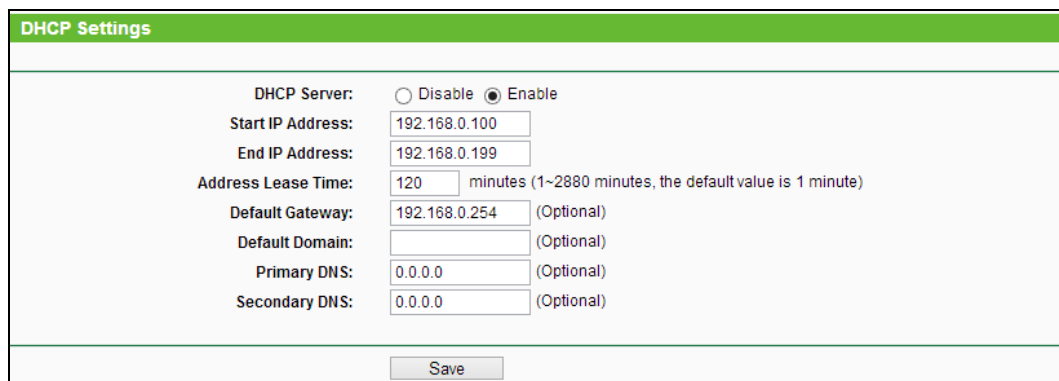

Figure 4-24 The DHCP menu

There are three submenus under the DHCP menu (shown in Figure 4-24), **DHCP Settings**, **DHCP Clients List** and **Address Reservation**. Click any of them, and you will be able to configure the corresponding function.

### 4.8.1 DHCP Settings

Choose menu “**DHCP** → **DHCP Settings**”, and then you can configure the DHCP Server on the page as shown in Figure 4-25. The Router is set up by default as a DHCP (Dynamic Host Configuration Protocol) server, which provides the TCP/IP configuration for all the PC(s) that are connected to the Router on the LAN.



The image shows the 'DHCP Settings' configuration page. It has a green header with the title 'DHCP Settings'. The main content area contains the following settings:

- DHCP Server:** Radio buttons for 'Disable' and 'Enable' (selected).
- Start IP Address:** Text input field containing '192.168.0.100'.
- End IP Address:** Text input field containing '192.168.0.199'.
- Address Lease Time:** Text input field containing '120' followed by 'minutes (1~2880 minutes, the default value is 1 minute)'.
- Default Gateway:** Text input field containing '192.168.0.254' with '(Optional)' to its right.
- Default Domain:** Text input field with '(Optional)' to its right.
- Primary DNS:** Text input field containing '0.0.0.0' with '(Optional)' to its right.
- Secondary DNS:** Text input field containing '0.0.0.0' with '(Optional)' to its right.

At the bottom of the form is a 'Save' button.

Figure 4-25 DHCP Settings

- **DHCP Server - Enable or Disable** the DHCP server. If you disable the Server, you must have another DHCP server within your network or else you must configure the computer manually.
- **Start IP Address** - Specify an IP address for the DHCP Server to start with when assigning IP addresses. 192.168.0.100 is the default start address.

- **End IP Address** - Specify an IP address for the DHCP Server to end with when assigning IP addresses. 192.168.0.199 is the default end address.
- **Address Lease Time** - The **Address Lease Time** is the amount of time a network user will be allowed connection to the Router with their current dynamic IP Address. Enter the amount of time in minutes and the user will be "leased" this dynamic IP Address. After the time is up, the user will be automatically assigned a new dynamic IP address. The range of the time is 1 ~ 2880 minutes. The default value is 120 minutes.
- **Default Gateway** (Optional) - It is suggested to input the IP address of the LAN port of the Router. The default value is 192.168.0.254.
- **Default Domain** (Optional) - Input the domain name of your network.
- **Primary DNS** - (Optional) Input the DNS IP address provided by your ISP or consult your ISP. Or consult your ISP.
- **Secondary DNS** (Optional) - Input the IP address of another DNS server if your ISP provides two DNS servers.

 **Note:**

To use the DHCP server function of the Router, you must configure all computers on the LAN as "Obtain an IP Address automatically".

#### 4.8.2 DHCP Client List

Choose menu "DHCP → DHCP Client List", and then you can view the information about the clients attached to the Router in the screen as shown in Figure 4-26.

DHCP Client List				
ID	Client Name	MAC Address	Assigned IP	Lease Time
1	tplink14129	6C-62-6D-F7-31-8D	192.168.0.100	01:15:47
2	Unknown	70-73-CB-1F-C8-C9	192.168.0.101	01:56:32

Figure 4-26 DHCP Client List

- **Client Name** - The name of the DHCP client
- **MAC Address** - The MAC address of the DHCP client
- **Assigned IP** - The IP address that the Router has allocated to the DHCP client
- **Lease Time** - The time of the DHCP client leased. After the dynamic IP address has expired, a new dynamic IP address will be automatically assigned to the user.

You cannot change any of the values on this page. To update this page and to show the current attached devices, click the **Refresh** button.

### 4.8.3 Address Reservation

Choose menu “**DHCP → Address Reservation**”, and then you can view and add a reserved address for clients via the next screen (shown in Figure 4-27).When you specify a reserved IP address for a PC on the LAN, that PC will always receive the same IP address each time when it accesses the DHCP server. Reserved IP addresses should be assigned to the servers that require permanent IP settings.

ID	MAC Address	Reserved IP Address	Status	Modify
1	00-11-22-33-44-AA	192.168.0.169	Enabled	<a href="#">Modify</a> <a href="#">Delete</a>

Buttons: Add New..., Enable All, Disable All, Delete All

Navigation: Previous, Next

Figure 4-27 Address Reservation

- **MAC Address** - The MAC address of the PC for which you want to reserve an IP address.
- **Reserved IP Address** - The IP address reserved for the PC by the Router.
- **Status** - The status of this entry, either **Enabled** or **Disabled**.
- **Modify** - To modify or delete an existing entry.

#### To Reserve an IP address:

1. Click the **Add New...** button. Then will pop-up.
2. Enter the MAC address (in XX-XX-XX-XX-XX-XX format.) and IP address (in dotted-decimal notation) of the computer for which you want to reserve an IP address.
3. Click the **Save** button.

Form fields:

- MAC Address:
- Reserved IP Address:
- Status:  (dropdown)

Buttons: Save, Back

Figure 4-28 Add or Modify an Address Reservation Entry

#### To modify an existing entry:

1. Click the **Modify** in the entry you want to modify.
2. Modify the information.
3. Click the **Save** button.

Click the **Delete** in the entry you want to delete to delete an existing entry.

Click the **Enable/Disable All** button to make all entries enabled/disabled.

Click the **Delete All** button to delete all entries.

Click the **Next** button to go to the next page and Click the **Previous** button to return the previous page.

## 4.9 USB Settings

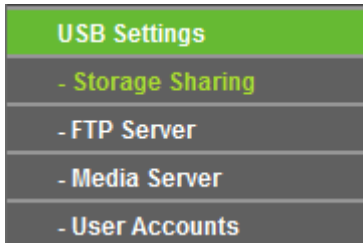

Figure 4-29 The USB Settings menu

There are four submenus under the USB Settings menu (shown in Figure 4-29), **Storage Sharing**, **FTP Server**, **Media Server** and **User Accounts**. Click any of them, and you will be able to configure the corresponding functions.

### 4.9.1 Storage Sharing

Choose menu "**USB Settings**→**Storage Sharing**", you can configure a USB disk drive attached to the router and view volume and share such properties as share name, capacity, used space, and free space on this page as shown below.

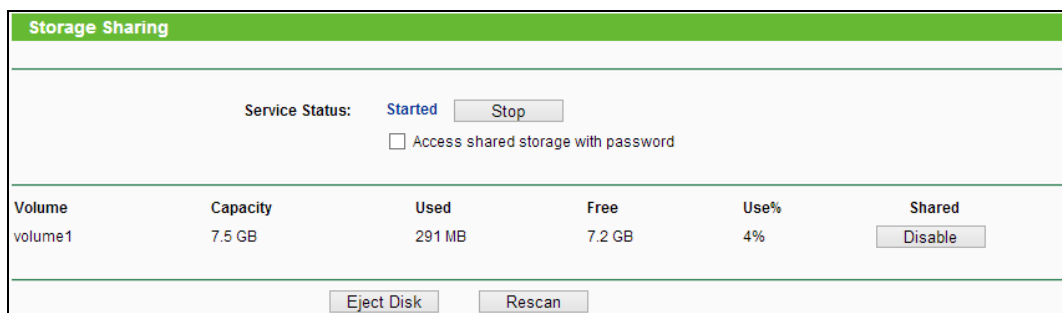

Figure 4-30 Storage Sharing

- **Service Status** - Indicates the Network Sharing service's current status. You can click the **Start** button to start the Storage Sharing service and click the **Stop** button to stop it.
- **Volume** - The volume name of the USB drive the users have access to. Volume 1-8 is mapping to USB port1, and Volume 9-16 is mapping to USB port2.
- **Capacity** - The storage capacity of the USB driver.
- **Used** - The used space of the USB driver.
- **Free** - The available space of the USB driver.
- **Use%** - The percentage of the used space.

- **Shared** - Indicates the shared or non-shared status of the volume. When the volume is shared, you can click the **Disable** to stop sharing the volume; when volume is non-shared, you can click the **Enable** button to share the volume.

Click the **Start** button to start the Network Sharing service.

Click the **Stop** button to stop the Network Sharing service.

Click the **Eject Disk** button to safely remove the USB storage device that is connected to USB port. This takes the drive offline. A message (as shown in Figure 4-31) will appear on your web browser when it is safe to detach the USB disk.

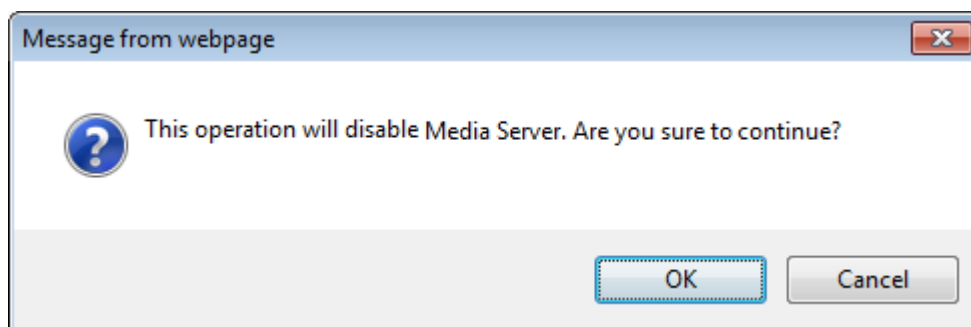

Figure 4-31 Safe Unplug Message

Click the **Rescan** button to start a new scan.

**Follow the instructions below to set up your router as a file server:**

1. Plug an external USB hard disk drive or USB flash drive into this router.
2. Click the **Rescan** button to find the USB drive that has been attached to the router.
3. Click the **Start** button to start the Storage Sharing service.
4. Click the **Enable** button under **Shared** to enable the disk to share.
5. Click the **Open the disk** to visit the sharing disk.

**Note:**

1. The router can automatically locate new USB drive. But to display the information about your USB device, you need to click the **Rescan** button manually.
2. The new settings will not take effect until you restart the service.
3. To unplug the USB drive, click **Eject Disk** button first. Simply pulling USB drive out of the USB port can cause damage to the device and loss of data.
4. Mounted volumes of each USB port are subject to the 8-volume limit. So you cannot access more than 8 volumes on the USB storage device.
5. If you change the storage settings during the storage connection is established, then the changes will not take effect until the router or the client is rebooted.

## 4.9.2 FTP Server

Choose menu “**USB Settings**→**FTP Server**”, you can create an FTP server that can be accessed from the Internet or your local network.

Name	Partition	Folder	Modify
folder1	volume1	volume1	<a href="#">Edit</a> <a href="#">Delete</a>

Figure 4-32 FTP Server Configuration

- **Service Status** - Indicates the FTP Server's current status.
- **Internet Access** - Select enable to allow access of the FTP server from the Internet. Otherwise, select disable to only allow local network access.
- **Service Port** - Enter the FTP Port number to use. The default is 21.
- **Name** - This folder's display name.
- **Partition** - The volume that the folder resides. Volume 1-8 is mapping to USB port1, and Volume 9-16 is mapping to USB port2.
- **Folder** - The real full path of the specified folder.

### To set up your FTP Server, please follow the instructions below:

1. Plug an external USB hard disk drive or USB flash drive into this Router.
2. Click the **Enable/Disable** radio box to enable/disable Internet access to FTP from Internet port.
3. Specify a port for the FTP server to use (The default port number is 21).
4. The **Internet Address** displays the WAN IP address of this router, so that other users can access FTP via this address.
5. If WAN type is PPPoE/PPTP/L2TP, two connections will be available. Therefore, users can access FTP server via two connections. Users in a private LAN can access ftp server via **Public Address** while Internet users can access ftp server via **Internet Address**.
6. Click the **Start** button to start the ftp server.

### To add a new folder, follow the instructions below.

1. Click **Add New Folder** in Figure 4-32.

Figure 4-33 Add or Modify Share Folder

2. Select the **Share entire partition** or a specific folder option.
3. Enter display name of the share folder in **Display Name** field.
4. Click the **Save** button to save the settings.

You can click the **upper** button to go to the upper folder.

You can click the **Back** button to return to the ftp server configuration page.

**Note:**

- 1) The max share folders number is 10. If you want to share a new folder when the number has reached 10, you can delete an existing share folder and then add a new one.
- 2) If you want to change the FTP settings, you need to restart FTP Server to make the changes take effect.

### 4.9.3 Media Server

Choose menu “**USB Settings**→**Media Server**”, you can create media server that allows you to share stored content with other computers and devices on your home network and on the Internet.

Figure 4-34 Media Server Setting

- **Server Name** - The name of this Media Server.
- **Server Status** - Indicates the Media Server’s current status, started or stopped. You can click the **Start** button to start the Media Server and click the **Stop** button to stop it.
- **Name** - The display name of this folder.

- **File System** - The file system type on the partition can be FAT32 or NTFS.
- **Folder** - The real full path of the specified folder.
- **Delete** - You can delete the share folder by click **Delete**.

**To set up your media server, please follow the instructions below:**

1. Plug an external USB hard disk drive or USB flash drive into this router.
2. Click the **Start** button to start the media server.
3. Click the **Add New Folder** button to specify a folder as the search path of media server. The screen will then appear as shown in Figure 4-35.

Figure 4-35 Add New Folder

- **Display Name** - You can enter a display name for the share folder.
  - **Share entire partition** - Choose this option and then the folders contained in this partition will all be shared.
  - **Folder Location**- Displays the location of this folder.
  - **Select** - Check the radio button to select the folder to share.
  - **Folder** - Displays folders that are in current path.
  - **Upper** - Click this button to get into the upper folder.
  - **Save** - Click this button to save your settings and the page will be redirected to the media server configuration page.
  - **Back** - Click this button to discard the settings and just go to the media server configuration page.
4. Click the **Scan All** button to scan all the share folders immediately. You can also select the **Auto-scan**, at same time, select an auto scan interval time by drop-down list. In this case, the media server will auto scan the share folders.



 **Note:**

The max share folders number is 6. If you want share a new folder when the number has been reached to be 6, you can delete a share folder and then add a new one.

#### 4.9.4 User Accounts

You can specify the user name and password for Storage Sharing users on this page. **Storage Sharing** users can use Internet Explorer to access files on the USB drive.

There are two default user accounts that can access the Storage Sharing. They are Administrator and Guest (as shown in Figure 4-36). Administrator has read/write access to Storage Sharing and can access FTP Server while Guest has read-only access to Storage Sharing and cannot access FTP Server.

User Account Management				
<a href="#">Add New User</a>				
User Name	Password	Storage Authority	FTP Access	Modify
admin	admin	Read and Write	Read and Write	<a href="#">Edit</a>

Figure 4-36 User Account Management

Only Administrator can use a Web browser to transfer the files from a PC to the Writable shared volume on the USB drive.

**To add a new user account, please follow the steps below:**

1. Click **Add New User** button, and the screen will appear as shown in Figure 4-37.
2. Self-define a **User Name**.
3. Enter the password in the **Password** field.
4. Choose the Storage Authority from the drop-down list, **Read and Write** or **Read Only**.

Add or Modify User Account	
User Name:	<input type="text" value="admin1"/>
Password:	<input type="text" value="admin"/>
Storage Authority:	<input type="text" value="Read Only"/> ▼
FTP Access:	<input type="text" value="No"/> ▼
<input type="button" value="Save"/> <input type="button" value="Back"/>	

Figure 4-37 Add or Modify User Account

- **User Name** - Type the user name that you want to give access to the USB drive. The user name must be composed of alphanumeric symbols not exceeding 15 characters in length.

- **Password** - Enter the password in the Password field. The password must be composed of alphanumeric symbols not exceeding 15 characters in length. For security purposes, the password for each user account is not displayed.
- **Storage Authority** - Choose **Read and Write** or **Read Only** from the drop-down list to assign access authority of Storage Sharing to the user.
- **Save** - You can click the **Save** button to save your settings.
- **Back** - You can click the **Back** button to discard the settings and just go to the media server configuration page.

 **Note:**

Please restart the service for the new settings to take effect.

If you cannot use the new user name and password to access the shares, press **Windows logo + R** to open the Run dialog box and type **net use \\192.168.0.254 /delete /yes** and press Enter. (192.168.0.254 is your router's LAN IP address. If the LAN IP of the modem connected with your router is 192.168.1.x, the default LAN IP of the router will automatically switch from 192.168.0.254 to 192.168.1.254 to avoid IP conflict; in this case, please try **net use \\192.168.1.254 /delete /yes**.)

## 4.10 Forwarding

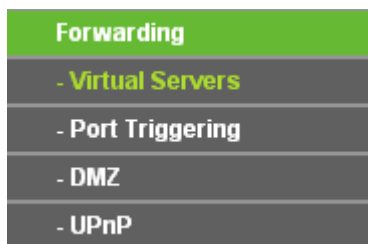

Figure 4-38 The Forwarding menu

There are four submenus under the Forwarding menu (shown in Figure 4-38): **Virtual Servers**, **Port Triggering**, **DMZ** and **UPnP**. Click any of them, and you will be able to configure the corresponding function.

### 4.10.1 Virtual Servers

Choose menu “**Forwarding** → **Virtual Servers**”, and then you can view and add virtual servers in the screen as shown in Figure 4-39. Virtual servers can be used for setting up public services on your LAN, such as DNS, Email and FTP. A virtual server is defined as a service port, and all requests from the Internet to this service port will be redirected to the computer specified by the server IP. Any PC that was used for a virtual server must have a static or reserved IP Address because its IP Address may be changed when using the DHCP function.

Virtual Servers						
ID	Service Port	Internal Port	IP Address	Protocol	Status	Modify
<input type="button" value="Add New..."/> <input type="button" value="Enable All"/> <input type="button" value="Disable All"/> <input type="button" value="Delete All"/>						
<input type="button" value="Previous"/> <input type="button" value="Next"/>						

Figure 4-39 Virtual Servers

- **Service Port** - The numbers of External Ports. You can type a service port or a range of service ports (in XXX - YYY format, XXX is the start port number, YYY is the end port number).
- **Internal Port** - The Internal Service Port number of the PC running the service application. You can leave it blank if the **Internal Port** is the same as the **Service Port**, or enter a specific port number when **Service Port** is a single one.
- **IP Address** - The IP Address of the PC providing the service application.
- **Protocol** - The protocol used for this application, either **TCP**, **UDP**, or **All** (all protocols supported by the Router).
- **Status** - The status of this entry, either **Enabled** or **Disabled**.
- **Modify** - To modify or delete an existing entry.

#### To setup a virtual server entry:

1. Click the **Add New...** button, the next screen will pop-up as shown in Figure 4-40.
2. Select the service port you want to use from the **Common Service Port** list. If the **Common Service Port** list does not have the service that you want to use, type the service port number or service port range in the **Service Port** box.
3. Type the IP Address of the computer in the **IP Address** box.
4. Select the protocol used for this application, either **TCP**, **UDP**, or **All**.
5. Select the **Enabled** to enable the virtual server.
6. Click the **Save** button.

Add or Modify a Virtual Server Entry	
Service Port:	<input type="text"/> (XX-XX or XX)
Internal Port:	<input type="text"/> (XX, Enter a specific port number or leave it blank)
IP Address:	<input type="text"/>
Protocol:	All <input type="button" value="v"/>
Status:	Enabled <input type="button" value="v"/>
Common Service Port:	--Select One-- <input type="button" value="v"/>
<input type="button" value="Save"/> <input type="button" value="Back"/>	

Figure 4-40 Add or Modify a Virtual Server Entry

**Note:**

If your computer or server has more than one type of available service, please select another service, and enter the same IP Address for that computer or server.

**To modify an existing entry:**

1. Click the **Modify** in the entry you want to modify.
2. Modify the information.
3. Click the **Save** button.

Click the **Delete** in the entry you want to delete to delete an existing entry.

Click the **Enable/Disable All** button to make all entries enabled/disabled.

Click the **Delete All** button to delete all entries.

Click the **Next** button to go to the next page and click the **Previous** button to return the previous page.

**Note:**

If you set the service port of the virtual server as 80, you must set the Web management port on “**Security → Remote Management**” page to be any other value except 80 such as 8080. Otherwise there will be a conflict to disable the virtual server.

**4.10.2 Port Triggering**

Choose menu “**Forwarding → Port Triggering**”, and then you can view and add port triggering in the screen as shown in Figure 4-41. Some applications require multiple connections, like Internet games, video conferencing, Internet calling and so on. These applications cannot work with a pure NAT Router. Port Triggering is used for some of these applications that can work with an NAT Router.

Port Triggering						
ID	Trigger Port	Trigger Protocol	Incoming Ports	Incoming Protocol	Status	Modify
<input type="button" value="Add New..."/> <input type="button" value="Enable All"/> <input type="button" value="Disable All"/> <input type="button" value="Delete All"/>						
<input type="button" value="Previous"/> <input type="button" value="Next"/>						

Figure 4-41 Port Triggering

Once the Router is configured, the operation is as follows:

1. A local host makes an outgoing connection using a destination port number defined in the Trigger Port field.
2. The Router records this connection, opens the incoming port or ports associated with this entry in the Port Triggering table, and associates them with the local host.
3. When necessary, the external host will be able to connect to the local host using one of the ports defined in the **Incoming Ports** field.

- **Trigger Port** - The port for outgoing traffic. An outgoing connection using this port will trigger this rule.
- **Trigger Protocol** - The protocol used for Trigger Ports, either **TCP**, **UDP**, or **All** (all protocols supported by the Router).
- **Incoming Ports** - The port or port range used by the remote system when it responds to the outgoing request. A response using one of these ports will be forwarded to the PC that triggered this rule. You can input at most 5 groups of ports (or port sections). Every group of ports must be set apart with ",". For example, 2000-2038, 2050-2051, 2085, 3010-3030.
- **Incoming Protocol** - The protocol used for Incoming Ports Range, either **TCP** or **UDP**, or **ALL** (all protocols supported by the Router).
- **Status** - The status of this entry, either **Enabled** or **Disabled**.
- **Modify** - To modify or delete an existing entry.

**To add a new rule, follow the steps below:**

1. Click the **Add New...** button, the next screen will pop-up as shown in Figure 4-42.
2. Select a common application from the **Common Applications** drop-down list, then the **Trigger Port** field and the **Incoming Ports** field will be automatically filled. If the **Common Applications** do not have the application you need, enter the **Trigger Port** and the **Incoming Ports** manually.
3. Select the protocol used for Trigger Port from the **Trigger Protocol** drop-down list, either **TCP**, **UDP**, or **All**.
4. Select the protocol used for Incoming Ports from the **Incoming Protocol** drop-down list, either **TCP** or **UDP**, or **All**.
5. Select **Enabled** in **Status** field.
6. Click the **Save** button to save the new rule.

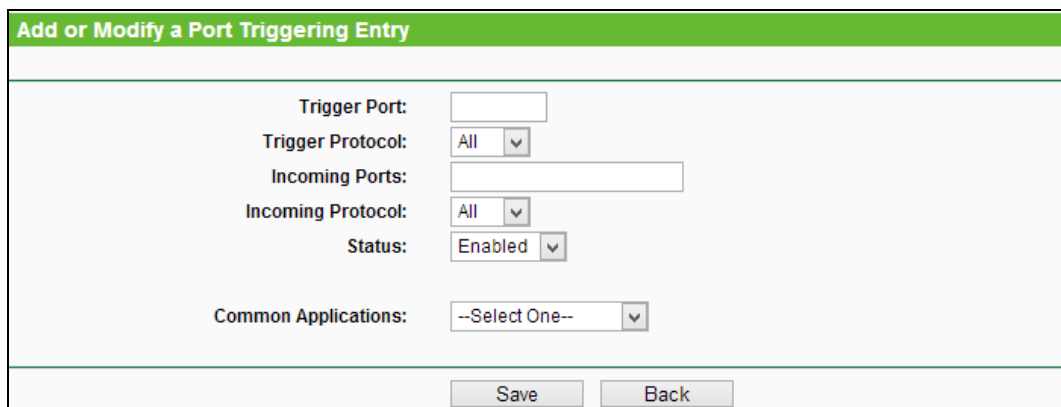

**Add or Modify a Port Triggering Entry**

Trigger Port:

Trigger Protocol: All ▾

Incoming Ports:

Incoming Protocol: All ▾

Status: Enabled ▾

Common Applications: --Select One-- ▾

Save Back

Figure 4-42 Add or Modify a Port Triggering Entry

**To modify an existing entry:**

1. Click the **Modify** in the entry you want to modify.

2. Modify the information.
3. Click the **Save** button.

Click the **Delete** in the entry you want to delete to delete an existing entry.

Click the **Enable All** button to make all entries enabled.

Click the **Disable All** button to make all entries disabled.

Click the **Delete All** button to delete all entries.

 **Note:**

1. When the trigger connection is released, the corresponding opening ports will be closed.
2. Each rule is allowed to be used only by one host on LAN synchronously. The trigger connection of other hosts on LAN will be refused.
3. Incoming Port Range cannot overlap each other.

### 4.10.3 DMZ

Choose menu “**Forwarding** → **DMZ**”, and then you can view and configure DMZ host in the screen as shown in Figure 4-43. The DMZ host feature allows one local host to be exposed to the Internet for a special-purpose service such as Internet gaming or videoconferencing. DMZ host forwards all the ports at the same time. Any PC whose port is being forwarded must have its DHCP client function disabled and should have a new static IP Address assigned to it because its IP Address may be changed when using the DHCP function.

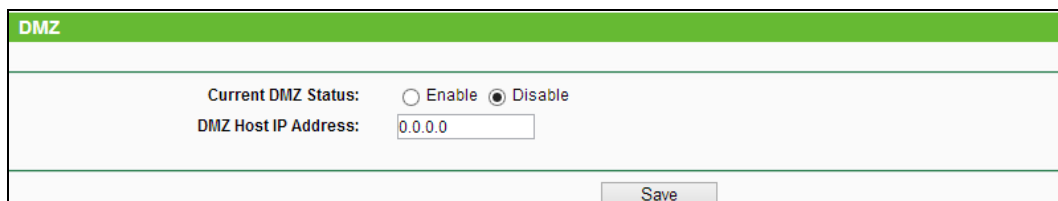

Figure 4-43 DMZ

#### To assign a computer or server to be a DMZ server:

1. Check the **Enable** radio button.
2. Enter the IP Address of a local host in the **DMZ Host IP Address** field.
3. Click the **Save** button.

 **Note:**

After you set the DMZ host, the firewall related to the host will not work.

### 4.10.4 UPnP

Choose menu “**Forwarding** → **UPnP**”, and then you can view the information about **UPnP** (Universal Plug and Play) in the screen as shown in Figure 4-44. The UPnP feature allows the devices, such as Internet computers, to access the local host resources or devices as needed. UPnP devices can be automatically discovered by the UPnP service application on the LAN.



Figure 4-44 UPnP

- **Current UPnP Status** - UPnP can be enabled or disabled by clicking the **Enable** or **Disable** button.
- **Current UPnP Settings List** - This table displays the current UPnP information.
  - **App Description** - The description provided by the application in the UPnP request.
  - **External Port** - The external port the Router opens for the application.
  - **Protocol** - The type of protocol the Router opens for the application.
  - **Internal Port** - The Internal port the Router opens for local host.
  - **IP Address** - The IP address of the UPnP device that is currently accessing the Router.
  - **Status** - The status of the port is displayed here. “Enabled” means that the port is still active. Otherwise, the port is inactive.

Click **Refresh** to update the Current UPnP Settings List.

## 4.11 Security



Figure 4-45 The Security menu

There are four submenus under the Security menu as shown in Figure 4-45: **Basic Security**, **Advanced Security**, **Local Management** and **Remote Management**. Click any of them, and you will be able to configure the corresponding function.

### 4.11.1 Basic Security

Choose menu “**Security** → **Basic Security**”, you can configure the basic security in the screen as shown in Figure 4-46.

Basic Security	
<b>Firewall</b>	
SPI Firewall:	<input checked="" type="radio"/> Enable <input type="radio"/> Disable
<b>VPN</b>	
PPTP Passthrough:	<input checked="" type="radio"/> Enable <input type="radio"/> Disable
L2TP Passthrough:	<input checked="" type="radio"/> Enable <input type="radio"/> Disable
IPSec Passthrough:	<input checked="" type="radio"/> Enable <input type="radio"/> Disable
<b>ALG</b>	
FTP ALG:	<input checked="" type="radio"/> Enable <input type="radio"/> Disable
TFTP ALG:	<input checked="" type="radio"/> Enable <input type="radio"/> Disable
H323 ALG:	<input checked="" type="radio"/> Enable <input type="radio"/> Disable
RTSP ALG:	<input checked="" type="radio"/> Enable <input type="radio"/> Disable
SIP ALG:	<input checked="" type="radio"/> Enable <input type="radio"/> Disable
<input type="button" value="Save"/>	

Figure 4-46 Basic Security

- **Firewall** - A firewall protects your network from the outside world. Here you can enable or disable the Router's firewall.
  - **SPI Firewall** - SPI (Stateful Packet Inspection, also known as dynamic packet filtering) helps to prevent cyber attacks by tracking more state per session. It validates that the traffic passing through the session conforms to the protocol. SPI Firewall is enabled by factory default. If you want all the computers on the LAN exposed to the outside world, you can disable it.
- **VPN** - VPN Passthrough must be enabled if you want to allow VPN tunnels using IPSec, PPTP, or L2TP protocols to pass through the Router's firewall.
  - **PPTP Passthrough** - Point-to-Point Tunneling Protocol (PPTP) allows the Point-to-Point Protocol (PPP) to be tunneled through an IP network. To allow PPTP tunnels to pass through the Router, keep the default, **Enable**.
  - **L2TP Passthrough** - Layer 2 Tunneling Protocol (L2TP) is the method used to enable Point-to-Point sessions via the Internet on the Layer 2 level. To allow L2TP tunnels to pass through the Router, keep the default, **Enable**.
  - **IPSec Passthrough** - Internet Protocol Security (IPSec) is a suite of protocols for ensuring private, secure communications over Internet Protocol (IP) networks, through the use of cryptographic security services. To allow IPSec tunnels to pass through the Router, keep the default, **Enable**.
- **ALG** - It is recommended to enable Application Layer Gateway (ALG) because ALG allows customized Network Address Translation (NAT) traversal filters to be plugged into the gateway to support address and port translation for certain application layer "control/data" protocols such as FTP, TFTP, H323 etc.



- **FTP ALG** - To allow FTP clients and servers to transfer data across NAT, keep the default **Enable**.
- **TFTP ALG** - To allow TFTP clients and servers to transfer data across NAT, keep the default **Enable**.
- **H323 ALG** - To allow Microsoft NetMeeting clients to communicate across NAT, keep the default **Enable**.
- **RTSP ALG** - To allow some media player clients to communicate with some streaming media servers across NAT, click **Enable**.
- **SIP ALG** - To allow some multimedia clients to communicate across NAT, click **Enable**.

Click the **Save** button to save your settings.

#### 4.11.2 Advanced Security

Choose menu “**Security** → **Advanced Security**”, you can protect the Router from being attacked by TCP-SYN Flood, UDP Flood and ICMP-Flood in the screen as shown in Figure 4-47.

Figure 4-47 Advanced Security

- **Packets Statistics Interval (5~60)** - The default value is 10. Select a value between 5 and 60 seconds from the drop-down list. The Packets Statistics Interval value indicates the time section of the packets statistics. The result of the statistics is used for analysis by SYN Flood, UDP Flood and ICMP-Flood.
- **DoS Protection** - Denial of Service protection. Check the Enable or Disable button to enable or disable the DoS protection function. Only when it is enabled, will the flood filters be enabled.

 **Note:**

Dos Protection will take effect only when the **Traffic Statistics** in “**System Tools** → **Traffic Statistics**” is enabled.

- **Enable ICMP-FLOOD Attack Filtering** - Enable or Disable the ICMP-FLOOD Attack Filtering.
- **ICMP-FLOOD Packets Threshold (5~3600)** - The default value is 50. Enter a value between 5 ~ 3600. When the current ICMP-FLOOD Packets number is beyond the set value, the Router will startup the blocking function immediately.
- **Enable UDP-FLOOD Filtering** - Enable or Disable the UDP-FLOOD Filtering.
- **UDP-FLOOD Packets Threshold (5~3600)** - The default value is 500. Enter a value between 5 ~ 3600. When the current UPD-FLOOD Packets number is beyond the set value, the Router will startup the blocking function immediately.
- **Enable TCP-SYN-FLOOD Attack Filtering** - Enable or Disable the TCP-SYN-FLOOD Attack Filtering.
- **TCP-SYN-FLOOD Packets Threshold (5~3600)** - The default value is 50. Enter a value between 5 ~ 3600. When the current TCP-SYN-FLOOD Packets numbers is beyond the set value, the Router will startup the blocking function immediately.
- **Ignore Ping Packet From WAN Port** - Enable or Disable Ignore Ping Packet From WAN Port. The default setting is disabled. If enabled, the ping packet from the Internet cannot access the Router.
- **Forbid Ping Packet From LAN Port** - Enable or Disable Forbid Ping Packet From LAN Port. The default setting is disabled. If enabled, the ping packet from LAN cannot access the Router. This function can be used to defend against some viruses.

Click the **Save** button to save the settings.

Click the **Blocked DoS Host List** button to display the DoS host table by blocking.

### 4.11.3 Local Management

Choose menu “**Security** → **Local Management**”, you can configure the management rule in the screen as shown in Figure 4-48. The management feature allows you to deny computers in LAN from accessing the Router.

Figure 4-48 Local Management

By default, the radio button “**All the PCs on the LAN are allowed to access the Router's Web-Based Utility**” is checked. If you want to allow PCs with specific MAC Addresses to access the Setup page of the Router's Web-Based Utility locally from inside the network, check the radio button “**Only the PCs listed can browse the built-in web pages to perform Administrator tasks**”, and then enter each MAC Address in a separate field. The format for the MAC Address is XX-XX-XX-XX-XX-XX (X is any hexadecimal digit). Only the PCs with MAC address listed can use the password to browse the built-in web pages to perform Administrator tasks while all the others will be blocked.

After click the **Add** button, your PC's MAC Address will be placed in the list above.

Click the **Save** button to save your settings.

#### **Note:**

If your PC is blocked but you want to access the Router again, press and hold the WPS button for more than 5 seconds to reset the Router to factory defaults.

### 4.11.4 Remote Management

You can configure the Remote Management function on this page. This feature allows you to manage your Router from a remote location, via the Internet.

Figure 4-49 Remote Management

- **Web Management Port** - Web browser access normally uses the standard HTTP service port 80. This router's default remote management Web port number is 80. For greater security, you can change the remote management Web interface to a custom port by

entering that number in this box provided. Choose a number between 1024 and 65535, but do not use the number of any common service port.

- **Remote Management IP Address** - This is the current address you will use when accessing your router from the Internet. The default IP Address is 0.0.0.0. It means this function is disabled. To enable this function, change the default IP Address to another IP Address as desired.

To access the router, you will type your router's WAN IP Address into your browser's Address (in IE) or Location (in Navigator) box, followed by a colon and the custom port number. For example, if your Router's WAN address is 202.96.12.8 and you use port number 8080, enter in your browser: <http://202.96.12.8:8080>. You will be asked for the router's password. After successfully entering the password, you will be able to access the router's Web-based utility.

#### **Note:**

Be sure to change the router's default password to a very secure password.

## 4.12 Parental Control

Choose menu “**Parental Control**”, and you can configure the parental control in the screen as shown in Figure 4-50. The Parental Control function can be used to control the internet activities of the child, limit the child to access certain websites and restrict the time of surfing.

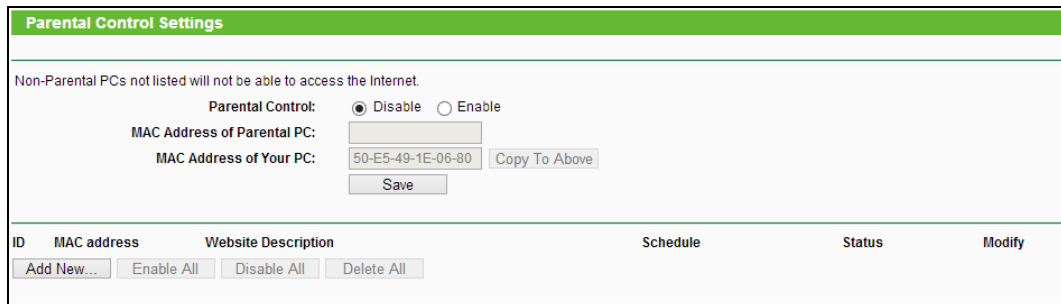

ID	MAC address	Website Description	Schedule	Status	Modify
<input type="button" value="Add New..."/> <input type="button" value="Enable All"/> <input type="button" value="Disable All"/> <input type="button" value="Delete All"/>					

Figure 4-50 Parental Control Settings

- **Parental Control** - Check **Enable** if you want this function to take effect, otherwise check **Disable**.
- **MAC Address of Parental PC** - In this field, enter the MAC address of the controlling PC, or you can make use of the **Copy To Above** button below.
- **MAC Address of Your PC** - This field displays the MAC address of the PC that is managing this Router. If the MAC Address of your adapter is registered, you can click the Copy To Above button to fill this address to the MAC Address of Parental PC field above.
- **Website Description** - Description of the allowed website for the PC controlled.
- **Schedule** - The time period allowed for the PC controlled to access the Internet. For detailed information, please go to “**Access Control**→ **Schedule**”.

- **Modify** - Here you can edit or delete an existing entry.

**To add a new entry, please follow the steps below.**

1. Click the **Add New...** button and the next screen will pop-up as shown in Figure 4-51.
2. Enter the MAC address of the PC (e.g. 00-11-22-33-44-AA) you'd like to control in the MAC Address of Child PC field. Or you can choose the MAC address from the All Address in Current LAN drop-down list.
3. Give a description (e.g. Allow TP-LINK) for the website allowed to be accessed in the Website Description field.
4. Enter the allowed domain name of the website, either the full name or the keywords (e.g. TP-LINK) in the Allowed Domain Name field. Any domain name with keywords in it (e.g. [www.tp-link.com](http://www.tp-link.com)) will be allowed.
5. Select from the Effective Time drop-down list the schedule (e.g. Schedule\_1) you want the entry to take effect. If there are not suitable schedules for you, click the **Schedule** in red below to go to the Advance Schedule Settings page and create the schedule you need.
6. In the Status field, you can select **Enabled** or **Disabled** to enable or disable your entry.
7. Click the **Save** button.

Click the **Enable All** button to enable all the rules in the list.

Click the **Disable All** button to disable all the rules in the list.

Click the **Delete All** button to delete all the entries in the table.

Click the **Next** button to go to the next page, or click the **Previous** button return to the previous page.

**Add or Modify Parental Control Entry**

The Schedule is based on the time of the Router. The time can be set in "System Tools -> [Time settings](#)".

MAC Address of Children's PC:

All MAC Address In Current LAN:

Website Description:

Allowed Website Name:

Effective Time:

The time schedule can be set in "Access Control -> [Schedule](#)"

Status:

Figure 4-51 Add or Modify Parental Control Entry

**For example:** If you desire that the child PC with MAC address 00-11-22-33-44-AA can access www.tp-link.com on Saturday only while the parent PC with MAC address 00-11-22-33-44-BB is without any restriction, you should follow the settings below.

1. Click "**Parental Control**" menu on the left to enter the Parental Control Settings page. Check **Enable** and enter the MAC address 00-11-22-33-44-BB in the MAC Address of Parental PC field.
2. Click "**Access Restriction** → **Schedule**" on the left to enter the Schedule Settings page. Click **Add New...** button to create a new schedule with Schedule Description is Schedule\_1, Day is Sat and Time is all day-24 hours.
3. Click "**Parental Control**" menu on the left to go back to the Add or Modify Parental Control Entry page:
  - Click **Add New...** button.
  - Enter 00-11-22-33-44-AA in the **MAC Address of Child PC** field.
  - Enter "Allow TP-LINK" in the **Website Description** field.
  - Enter "www.tp-link.com" in the **Allowed Domain Name** field.
  - Select "Schedule\_1" you create just now from the **Effective Time** drop-down list.
  - In **Status** field, select **Enable**.
4. Click **Save** to complete the settings.

Then you will go back to the Parental Control Settings page and see the following list, as shown in Figure 4-52.

ID	MAC address	Website Description	Schedule	Status	Modify
1	00-11-22-33-44-AA	Allow TP-LINK	Schedule_1	<input checked="" type="checkbox"/>	<a href="#">Edit</a> <a href="#">Delete</a>

Figure 4-52

## 4.13 Access Control

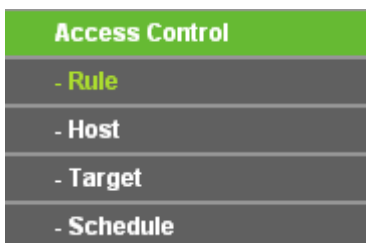

Figure 4-53 The Access Control menu

There are four submenus under the Access Restriction menu as shown in Figure 4-53: **Rule**, **Host**, **Target** and **Schedule**. Click any of them, and you will be able to configure the corresponding function.

### 4.13.1 Rule

Choose menu “**Access Control**→ **Rule**”, you can view and set Access Restriction rules in the screen as shown in Figure 4-54.

Figure 4-54 Access Control Rule Management

- **Enable Internet Access Control** - Select the check box to enable the Internet Access Restriction function, so the Default Filter Policy can take effect.
- **Rule Name** - Here displays the name of the rule and this name is unique.
- **Host** - Here displays the host selected in the corresponding rule.
- **Target** - Here displays the target selected in the corresponding rule.
- **Schedule** - Here displays the schedule selected in the corresponding rule.
- **Status** - This field displays the status of the rule. **Enabled** means the rule will take effect, **Disabled** means the rule will not take effect.
- **Modify** - Here you can edit or delete an existing rule.

**To add a new rule, please follow the steps below.**

1. Click the **Add New...** button and the next screen will pop-up as shown in Figure 4-55.
2. Give a name (e.g. Rule\_1) for the rule in the **Rule Name** field.
3. Select a host from the **Host** drop-down list or choose “**Click Here To Add New Host List**”.
4. Select a target from the **Target** drop-down list or choose “**Click Here To Add New Target List**”.
5. Select a schedule from the **Schedule** drop-down list or choose “**Click Here To Add New Schedule**”.
6. In the **Action** field, select **Deny** or **Allow**.
7. In the **Status** field, select **Enabled** or **Disabled** to enable or disable your entry.
8. Click the **Save** button.

Click the **Enable All** button to enable all the rules in the list.

Click the **Disable All** button to disable all the rules in the list.

Click the **Delete All** button to delete all the entries in the table.

You can change the entry's order as desired. Fore entries are before hind entries. Enter the ID number in the first box you want to move and another ID number in second box you want to move to, and then click the **Move** button to change the entry's order.

Click the **Next** button to go to the next page, or click the **Previous** button return to the previous page.

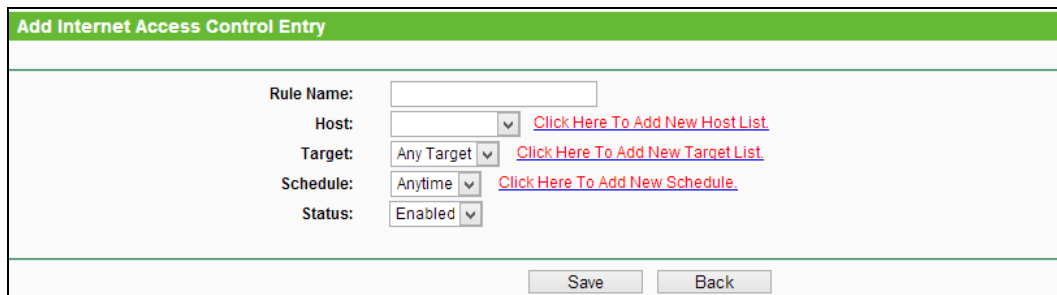

Figure 4-55 Add or Modify Internet Access Restriction Entry

**For example:** If you desire to allow the host with MAC address 00-11-22-33-44-AA to access **www.tp-link.com** only from **18:00** to **20:00** on **Saturday and Sunday**, and forbid other hosts in the LAN to access the Internet, you should follow the settings below:

1. Click "**Access Control** → **Host**" in the left to enter the Host Settings page. Add a new entry with the Host Description is Host\_1 and MAC Address is 00-11-22-33-44-AA.
2. Click "**Access Control** → **Target**" in the left to enter the Target Settings page. Add a new entry with the Target Description is Target\_1 and Domain Name is www.tp-link.com.
3. Click "**Access Control** → **Schedule**" in the left to enter the Schedule Settings page. Add a new entry with the Schedule Description is Schedule\_1, Day is Sat and Sun, Start Time is 1800 and Stop Time is 2000.
4. Click "**Access Control** → **Rule**" in the left to return to the Access Restriction Rule Management page. Select "**Enable Internet Access Restriction**" and choose "Deny the packets not specified by any access Restriction policy to pass through the Router".
5. Click **Add New...** button to add a new rule as follows:
  - In **Rule Name** field, create a name for the rule. Note that this name should be unique, for example Rule\_1.
  - In **Host** field, select Host\_1.
  - In **Target** field, select Target\_1.



- In **Schedule** field, select Schedule\_1.
- In **Action** field, select Allow.
- In **Status** field, select Enabled.
- Click **Save** to complete the settings.

Then you will go back to the Access Restriction Rule Management page and see the following list.

ID	Rule Name	Host	Target	Schedule	Status	Modify
1	Rule_1	<a href="#">Host_1</a>	<a href="#">Target_1</a>	<a href="#">Schedule_1</a>	<input checked="" type="checkbox"/>	<a href="#">Edit</a> <a href="#">Delete</a>

Setup Wizard

Add New... Enable All Disable All Delete All

Figure 4-56 Rule Settings

### 4.13.2 Host

Choose menu “**Access Control → Host**”, you can view and set a Host list in the screen as shown in Figure 4-57. The host list is necessary for the Access Restriction Rule.

Host Settings			
ID	Host Description	Information	Modify
Add New... Delete All			
Previous Next Current No. 1 Page			

Figure 4-57 Host Settings

- **Host Description** - Here displays the description of the host and this description is unique.
- **Information** - Here displays the information about the host. It can be IP or MAC.
- **Modify** - To modify or delete an existing entry.

**To add a new entry, please follow the steps below.**

1. Click the **Add New...** button.
2. In the **Mode** field, select IP Address or MAC Address.
  - If you select IP Address, the screen shown is Figure 4-58.
    - 1) In **Host Description** field, create a unique description for the host (e.g. Host\_1).
    - 2) In **LAN IP Address** field, enter the IP address.
  - If you select MAC Address, the screen shown is Figure 4-59.
    - 1) In **Host Description** field, create a unique description for the host (e.g. Host\_1).
    - 2) In **MAC Address** field, enter the MAC address.
3. Click the **Save** button to complete the settings.

Click the **Delete All** button to delete all the entries in the table.

Click the **Next** button to go to the next page, or click the **Previous** button return to the previous page.

The screenshot shows a web form titled "Add or Modify a Host Entry". It has a green header bar with the title. Below the header, there are three input fields: "Mode" with a dropdown menu set to "IP Address", "Host Description" with a text box, and "LAN IP Address" with two text boxes separated by a hyphen. At the bottom right, there are two buttons: "Save" and "Back".

Figure 4-58 Add or Modify a Host Entry

The screenshot shows the same "Add or Modify a Host Entry" form, but the "Mode" dropdown menu is now set to "MAC Address". The "Host Description" and "MAC Address" fields are visible, with the "MAC Address" field having a text box. The "Save" and "Back" buttons are still present at the bottom right.

Figure 4-59 Add or Modify a Host Entry

**For example:** If you desire to restrict the internet activities of host with MAC address 00-11-22-33-44-AA, you should first follow the settings below:

1. Click **Add New...** button in Figure 4-57 to enter the Add or Modify a Host Entry page.
2. In **Mode** field, select MAC Address from the drop-down list.
3. In **Host Description** field, create a **unique** description for the host (e.g. Host\_1).
4. In **MAC Address** field, enter 00-11-22-33-44-AA.
5. Click **Save** to complete the settings.

Then you will go back to the Host Settings page and see the following list.

The screenshot shows the "Host Settings" page. It has a green header bar with the title. Below the header, there is a table with the following columns: "ID", "Host Description", "Information", and "Modify". The table contains one row with ID "1", Host Description "Host\_1", and Information "MAC: 00-11-22-33-44-AA". Below the table, there are two buttons: "Add New..." and "Delete All". At the bottom, there are three buttons: "Previous", "Next", and "Current No. 1 Page", where "1" is in a dropdown menu.

ID	Host Description	Information	Modify
1	Host_1	MAC: 00-11-22-33-44-AA	<a href="#">Edit</a> <a href="#">Delete</a>

Figure 4-60 Host Settings

### 4.13.3 Target

Choose menu "**Access Control** → **Target**", you can view and set a Target list in the screen as shown in Figure 4-61. The target list is necessary for the Access Restriction Rule.

Target Settings			
ID	Target Description	Information	Modify
<input type="button" value="Add New..."/> <input type="button" value="Delete All"/>			
<input type="button" value="Previous"/> <input type="button" value="Next"/> Current No. <input type="text" value="1"/> Page			

Figure 4-61 Target Settings

- **Target Description** - Here displays the description about the target and this description is unique.
- **Information** - The target can be IP address, port, or domain name.
- **Modify** - To modify or delete an existing entry.

**To add a new entry, please follow the steps below.**

1. Click the **Add New...** button.
2. In **Mode** field, select IP Address or Domain Name.
  - If you select **IP Address**, the screen shown is Figure 4-62.
    - 1) In **Target Description** field, create a unique description for the target (e.g. Target\_1).
    - 2) In **IP Address** field, enter the IP address of the target.
    - 3) Select a common service from **Common Service Port** drop-down list, so that the **Target Port** will be automatically filled. If the **Common Service Port** drop-down list doesn't have the service you want, specify the **Target Port** manually.
    - 4) In **Protocol** field, select TCP, UDP, ICMP or ALL.
  - If you select **Domain Name**, the screen shown is Figure 4-63.
    - 1) In **Target Description** field, create a unique description for the target (e.g. Target\_1).
    - 2) In **Domain Name** field, enter the domain name, either the full name or the keywords (for example TP-LINK) in the blank. Any domain name with keywords in it (e.g. [www.tp-link.com](http://www.tp-link.com)) will be blocked or allowed. You can enter 4 domain names.
3. Click the **Save** button.

Click the **Delete All** button to delete all the entries in the table.

Click the **Next** button to go to the next page, or click the **Previous** button return to the previous page.

**Add or Modify an Access Target Entry**

Mode: IP Address

Target Description:

IP Address:  -

Target Port:  -

Protocol: All

Common Service Port: --Please Select--

Save Back

Figure 4-62 Add or Modify an Access Target Entry

**Add or Modify an Access Target Entry**

Mode: Domain Name

Target Description:

Domain Name:

Save Back

Figure 4-63 Add or Modify an Access Target Entry

**For example:** If you desire to restrict the internet activities of host with MAC address 00-11-22-33-44-AA in the LAN to access www.tp-link.com only, you should first follow the settings below:

1. Click **Add New...** button in Figure 4-61 to enter the Add or Modify an Access Target Entry page.
2. In **Mode** field, select Domain Name from the drop-down list.
3. In **Target Description** field, create a unique description for the target (e.g. Target\_1).
4. In **Domain Name** field, enter www.tp-link.com.
5. Click **Save** to complete the settings.

Then you will go back to the Target Settings page and see the following list,

ID	Target Description	Information	Modify
1	Target_1	www.tp-link.com	<a href="#">Edit</a> <a href="#">Delete</a>

Figure 4-64 Target Settings

#### 4.13.4 Schedule

Choose menu “**Access Control** → **Schedule**”, you can view and set a Schedule list in the next screen as shown in Figure 4-65. The Schedule list is necessary for the Access Restriction Rule.

ID	Schedule Description	Day	Time	Modify
<input type="button" value="Add New..."/> <input type="button" value="Delete All"/>				
<input type="button" value="Previous"/> <input type="button" value="Next"/> Current No. <input type="text" value="1"/> Page				

Figure 4-65 Schedule Settings

- **Schedule Description** - Here displays the description of the schedule and this description is unique.
- **Day** - Here displays the day(s) in a week.
- **Time** - Here displays the time period in a day.
- **Modify** - Here you can edit or delete an existing schedule.

**To add a new schedule, follow the steps below.**

1. Click **Add New...** button shown in Figure 4-65 and the next screen will pop-up as shown in Figure 4-66.
2. In **Schedule Description** field, create a unique description for the schedule (e.g. Schedule\_1).
3. In **Day** field, select the day or days you need.
4. In **Time** field, you can select all day-24 hours or you may enter the Start Time and Stop Time in the corresponding field.
5. Click **Save** to complete the settings.

Click the **Delete All** button to delete all the entries in the table.

Click the **Next** button to go to the next page, or click the **Previous** button return to the previous page.

**Advance Schedule Settings**

Note: The Schedule is based on the time of the Router.

Schedule Description:

Day:  Everyday  Select Days

Mon  Tue  Wed  Thu  Fri  Sat  Sun

Time: all day-24 hours:

Start Time:  (HHMM)

Stop Time:  (HHMM)

Figure 4-66 Advanced Schedule Settings

**For example:** If you desire to restrict the internet activities of host with MAC address 00-11-22-33-44-AA to access www.tp-link.com only from **18:00 to 20:00** on **Saturday** and **Sunday**, you should first follow the settings below:

1. Click **Add New...** button shown in Figure 4-65 to enter the Advanced Schedule Settings page.
2. In **Schedule Description** field, create a unique description for the schedule (e.g. Schedule\_1).
3. In **Day** field, check the Select Days radio button and then select Sat and Sun.
4. In **Time** field, enter 1800 in Start Time field and 2000 in Stop Time field.
5. Click **Save** to complete the settings.

Then you will go back to the Schedule Settings page and see the following list.

Schedule Settings					
ID	Schedule Description	Day	Time	Modify	
1	Schedule_1	Sat Sun	18:00 - 20:00	<a href="#">Edit</a> <a href="#">Delete</a>	
<input type="button" value="Add New..."/> <input type="button" value="Delete All"/>					
<input type="button" value="Previous"/> <input type="button" value="Next"/> Current No. <input type="text" value="1"/> Page					

Figure 4-67 Schedule Settings

## 4.14 Advanced Routing

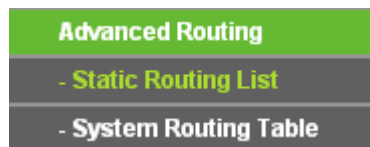

Figure 4-68 The Advanced Routing Menu

There are two submenus under the Network menu (shown in Figure 4-68): **Static Routing List** and **System Routing Table**. Click any of them, and you will be able to configure the corresponding function.

### 4.14.1 Static Routing List

Choose menu “**Static Routing**”, and you can configure the static route in the next screen, shown in Figure 4-69. A static route is a pre-determined path that network information must travel to reach a specific host or network.

Static Routing						
ID	Destination Network	Subnet Mask	Default Gateway	Status	Modify	
<input type="button" value="Add New..."/> <input type="button" value="Enable All"/> <input type="button" value="Disable All"/> <input type="button" value="Delete All"/>						
<input type="button" value="Previous"/> <input type="button" value="Next"/>						

Figure 4-69 Static Routing

**To add static routing entries, follow the steps below.**

1. Click **Add New...** shown in Figure 4-69, you will see the following screen Figure 4-70.

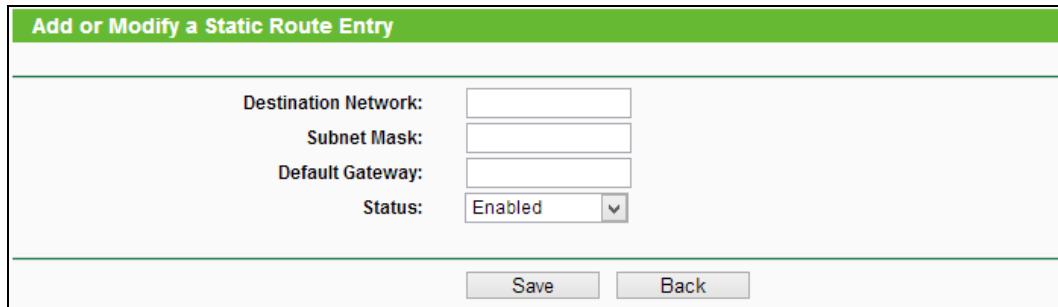

The screenshot shows a web interface for adding or modifying a static route entry. The title bar is green and contains the text "Add or Modify a Static Route Entry". Below the title bar, there are four input fields: "Destination Network:", "Subnet Mask:", "Default Gateway:", and "Status:". The "Status:" field is a dropdown menu with "Enabled" selected. At the bottom of the form, there are two buttons: "Save" and "Back".

Figure 4-70 Add or Modify a Static Route Entry

2. Enter the following data.
  - **Destination Network** - The **Destination IP Address** is the address of the network or host that you want to assign to a static route.
  - **Subnet Mask** - The **Subnet Mask** determines which portion of an IP Address is the network portion, and which portion is the host portion.
  - **Default Gateway** - This is the IP Address of the gateway device that allows for contact between the Router and the network or host.
3. Select **Enabled** or **Disabled** for this entry on the **Status** drop-down list.
4. Click the **Save** button to make the entry take effect.
  - Click the **Delete** button to delete the entry.
  - Click the **Enable All** button to enable all the entries.
  - Click the **Disable All** button to disable all the entries.
  - Click the **Delete All** button to delete all the entries.
  - Click the **Previous** button to view the information in the previous screen, click the **Next** button to view the information in the next screen.

#### 4.14.2 System Routing Table

Choose menu “**Advanced Routing** → **System Routing Table**”, and you can view all of the valid route entries in use. The Destination IP address, Subnet Mask, Gateway, and Interface will be displayed for each entry.

System Routing Table				
ID	Destination Network	Subnet Mask	Gateway	Interface
1	192.168.1.0	255.255.255.0	0.0.0.0	WAN
2	192.168.0.0	255.255.255.0	0.0.0.0	LAN & WLAN
3	239.0.0.0	255.0.0.0	0.0.0.0	LAN & WLAN
4	0.0.0.0	0.0.0.0	192.168.1.161	WAN

Figure 4-71 Routing Table

- **Destination Network** - The Destination IP Address is the address of the network or host to which the static route is assigned.
- **Subnet Mask** - The Subnet Mask determines which portion of an IP address is the network portion, and which portion is the host portion.
- **Gateway** - This is the IP address of the gateway device that allows for contact between the Router and the network or host.
- **Interface** - This interface tells you whether the Destination IP Address is on the **LAN & WLAN** (internal wired and wireless networks), the **WAN (Internet)**.

Click the **Refresh** button to refresh the data displayed.

## 4.15 Bandwidth Control

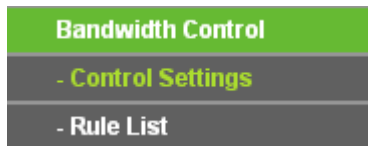

Figure 4-72 The Bandwidth Control menu

There are two submenus under the Bandwidth Control menu as shown in Figure 4-72. Click any of them, and you will be able to configure the corresponding function. The detailed explanations for each submenu are provided below.

### 4.15.1 Control Settings

Choose menu "**Bandwidth Control** → **Control Settings**", you can configure the Egress Bandwidth and Ingress Bandwidth in the next screen. Their values you configure should be less than 100000Kbps. For optimal control of the bandwidth, please select the right Line Type and ask your ISP for the total bandwidth of the egress and ingress.



Figure 4-73 Bandwidth Control Settings

- **Enable Bandwidth Control** - Check this box so that the Bandwidth Control settings can take effect.
- **Line Type** - Select the right type for you network connection. If you don't know how to choose, please ask your ISP for the information.
- **Egress Bandwidth** - The upload speed through the WAN port.
- **Ingress Bandwidth** - The download speed through the WAN port.

#### 4.15.2 Rule List

Choose menu "**Bandwidth Control** → **Rule List**", you can view and configure the Bandwidth Control rules in the screen below.

ID	Description	Egress Bandwidth(Kbps)		Ingress Bandwidth(Kbps)		Enable	Modify
		Min	Max	Min	Max		
The current list is empty.							

Current No.  Page

Figure 4-74 Bandwidth Control Rule List

- **Description** - This is the information about the rules such as address range.
- **Egress Bandwidth** - This field displays the max and mix upload bandwidth through the WAN port, the default is 0.
- **Ingress Bandwidth** - This field displays the max and mix download bandwidth through the WAN port, the default is 0.
- **Enable** - This displays the status of the rule.
- **Modify** - Click **Modify** to edit the rule. Click **Delete** to delete the rule.

**To add/modify a Bandwidth Control rule, follow the steps below.**

**Step 1:** Click **Add New...** shown in Figure 4-74, you will see a new screen shown in Figure 4-75.

**Step 2:** Enter the information like the screen shown below.

Figure 4-75 Bandwidth Control Rule Settings

- **Enable** - Enable or disable the rule.
- **IP Range** - Interior PC address range. If both are blank (or 0.0.0.0), the domain is no effective.
- **Port Range** - The port range which the Interior PC access the outside PC. If all are blank (or 0), the domain is no effective.
- **Protocol** - Transport layer protocol, here there are All, TCP, UDP.
- **Egress Bandwidth** - The max and the min upload speed which through the WAN port, default number is 0.
- **Ingress Bandwidth** - The max and the min download speed through the WAN port, default number is 0.

**Step 3:** Click the **Save** button.

## 4.16 IP & MAC Binding

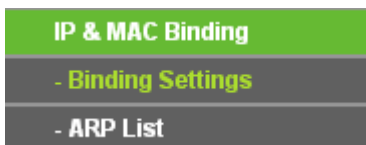

Figure 4-76 The IP &amp; MAC Binding menu

There are two submenus under the IP & MAC Binding menu: **Binding Setting** and **ARP List**. Click any of them, and you will be able to scan or configure the corresponding function. The detailed explanations for each submenu are provided below.

### 4.16.1 Binding Setting

This page displays the IP & MAC Binding Setting table; you can operate it in accord with your desire.

Figure 4-77 IP &amp; MAC Binding Setting

- **MAC Address** - The MAC address of the controlled computer in the LAN.
- **IP Address** - The assigned IP address of the controlled computer in the LAN.
- **Bind** - Whether or not enable the ARP binding.
- **Modify** - Edit or delete item.

When you want to add or modify an IP & MAC Binding entry, you can click the **Add New** button or **Modify** button, and then you will go to the next page. This page is used for adding or modifying an IP & MAC Binding entry.

Figure 4-78 IP &amp; MAC Binding Setting (Add &amp; Modify)

#### To add IP & MAC Binding entries:

1. Click the **Add New...** button.
2. Enter the MAC Address and IP Address.
3. Select the Bind checkbox.
4. Click the **Save** button to save it.

#### To modify or delete an existing entry:

1. Find the desired entry in the table.
2. Click **Modify** or **Delete** as desired on the **Modify** column.

To find an existing entry:

1. Click the **Find** button (shown in Figure 4-77).
2. Enter the MAC Address or IP Address.
3. Enter the **Find** button in the next page (shown in Figure 4-79).

ID	MAC Address	IP Address	Bind Link
1	00-0A-EB-00-07-BE	192.168.0.173	<input checked="" type="checkbox"/> <a href="#">To page</a>

Figure 4-79 Find IP & MAC Binding Entry

Click the **Enable All** button to make all entries enabled.

Click the **Delete All** button to delete all entries.

#### 4.16.2 ARP List

To manage the computer, you could observe the computers in the LAN by checking the relationship of MAC address and IP address on the ARP list, and you could configure the items on the ARP list also. This page displays the ARP List; it shows all the existing IP & MAC Binding entries.

ID	MAC Address	IP Address	Status	Configure
1	6C-62-6D-F7-31-8D	192.168.0.100	Unbound	<a href="#">Load Delete</a>
2	00-0A-EB-00-07-BE	192.168.0.173	Bound	<a href="#">Load Delete</a>

Figure 4-80 ARP List

- **MAC Address** - The MAC address of the controlled computer in the LAN.
- **IP Address** - The assigned IP address of the controlled computer in the LAN.
- **Status** - Enabled or Disabled of the MAC address and IP address binding.
- **Configure** - Load or delete item.
- **Load** - Load the item to the IP & MAC Binding list.

➤ **Delete** - Delete the item.

Click the **Bind All** button to bind all the current items, available after enable.

Click the **Load All** button to load all items to the IP & MAC Binding list.

Click the **Refresh** button to refresh all items.

 **Note:**

An item could not be loaded to the IP & MAC Binding list if the IP address of the item has been loaded before. Error warning will prompt as well. Likewise, "Load All" only loads the items without interference to the IP & MAC Binding list.

## 4.17 Dynamic DNS

The Router offers the **DDNS** (Dynamic Domain Name System) feature, which allows the hosting of a website, FTP server, or e-mail server with a fixed domain name (named by yourself) and a dynamic IP address, and then your friends can connect to your server by entering your domain name no matter what your IP address is. Before using this feature, you need to sign up for DDNS service providers such as [www.noip.com](http://www.noip.com), [www.comexe.cn](http://www.comexe.cn), or [www.dyn.com](http://www.dyn.com). The Dynamic DNS client service provider will give you a password or key.

### 4.17.1 No-IP DDNS

If the dynamic DNS **Service Provider** you select is [www.noip.com](http://www.noip.com), the page will appear as shown in Figure 4-81.

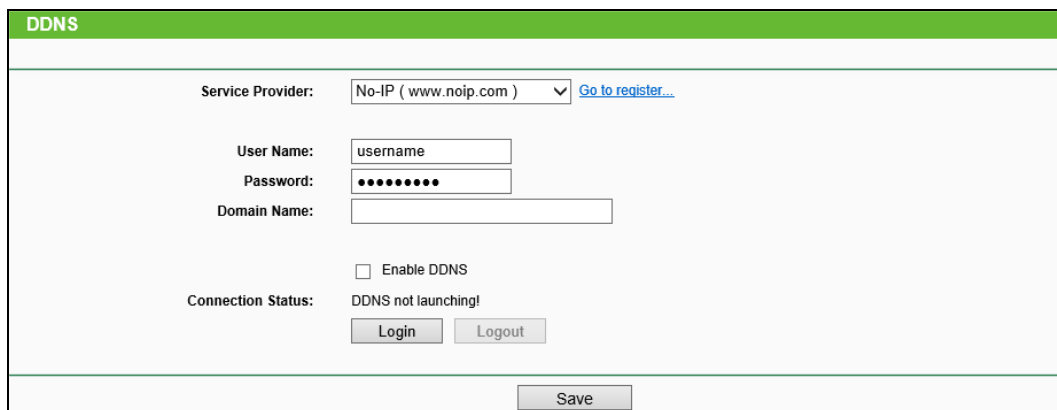

Figure 4-81 No-IP DDNS Settings

**To set up for DDNS, follow these instructions:**

1. Type the **User Name** for your DDNS account.
2. Type the **Password** for your DDNS account.
3. Type the **Domain Name** you received from dynamic DNS service provider.
4. Click the **Login** button to log in the DDNS service.

**Connection Status** - The status of the DDNS service connection is displayed here.

Click **Logout** to log out the DDNS service.

 **Note:**

If you want to login again with another account after a successful login, please click the **Logout** button, then input your new username and password and click the **Login** button.

#### 4.17.2 Comexe DDNS

If the dynamic DNS **Service Provider** you select is [www.comexe.cn](http://www.comexe.cn), the page will appear as shown in Figure 4-82.

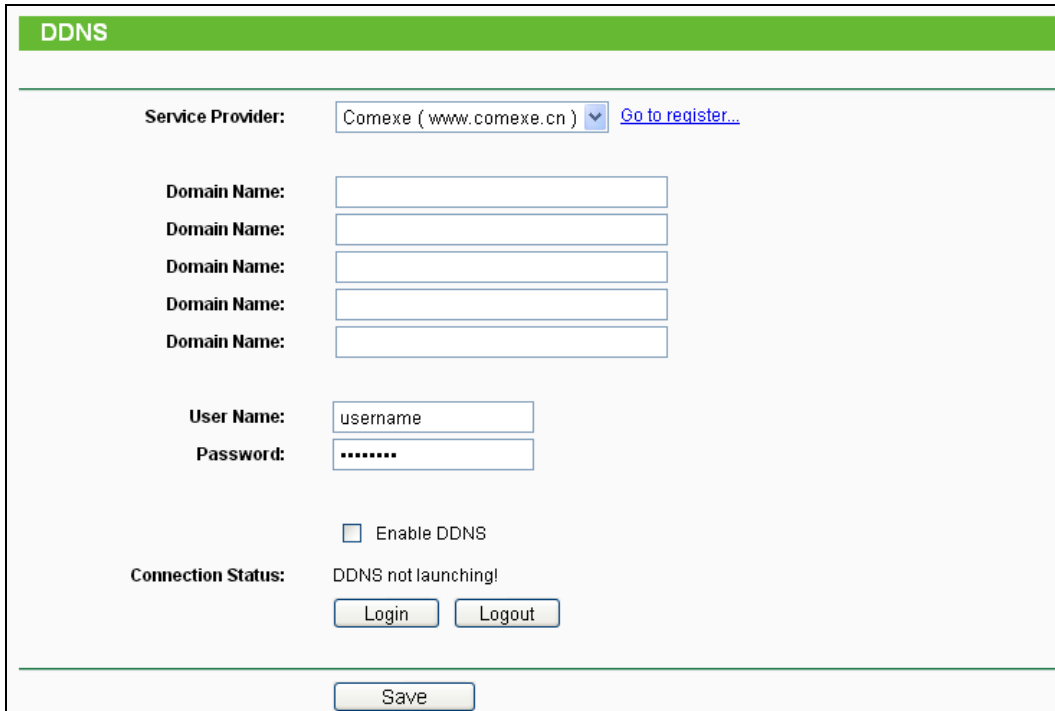

The screenshot shows the DDNS configuration interface. At the top, a green bar contains the text "DDNS". Below this, the "Service Provider" is set to "Comexe ( www.comexe.cn )" with a "Go to register..." link. There are five "Domain Name" input fields. Below these are "User Name" (with "username" entered) and "Password" (with "\*\*\*\*\*" entered) fields. There is an "Enable DDNS" checkbox which is unchecked. The "Connection Status" is "DDNS not launching!". At the bottom are "Login" and "Logout" buttons, and a "Save" button at the very bottom.

Figure 4-82 Comexe DDNS Settings

**To set up for DDNS, follow these instructions:**

1. Type the **Domain Name** received from your dynamic DNS service provider.
2. Type the **User Name** for your DDNS account.
3. Type the **Password** for your DDNS account.
4. Click the **Login** button to log in to the DDNS service.

**Connection Status** -The status of the DDNS service connection is displayed here.

Click **Logout** to log out of the DDNS service.

#### 4.17.3 DynDNS DDNS

If the dynamic DNS **Service Provider** you select is [www.dyn.com](http://www.dyn.com), the page will appear as shown in Figure 4-83.

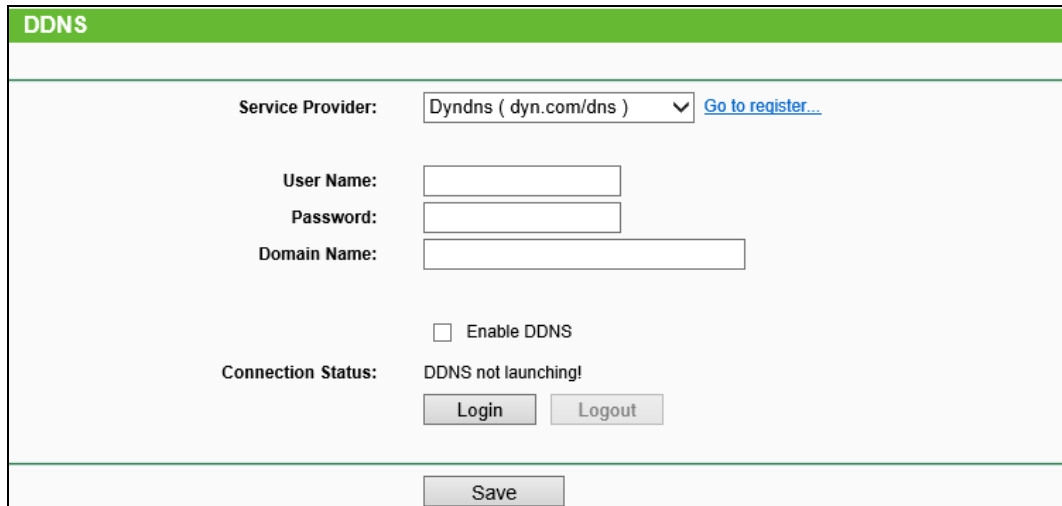

**DDNS**

Service Provider: Dyndns ( dyn.com/dns ) [Go to register...](#)

User Name:

Password:

Domain Name:

Enable DDNS

Connection Status: DDNS not launching!

Login Logout

Save

Figure 4-83 Dyndns DDNS Settings

To set up for DDNS, follow these instructions:

1. Type the **User Name** for your DDNS account.
2. Type the **Password** for your DDNS account.
3. Type the **Domain Name** you received from dynamic DNS service provider here.
4. Click the **Login** button to log in to the DDNS service.

**Connection Status** -The status of the DDNS service connection is displayed here.

Click **Logout** to logout of the DDNS service.

## 4.18 System Tools



Figure 4-84 The System Tools menu

There are nine submenus under the System Tools menu: **Time Settings**, **Diagnostic**, **Firmware Upgrade**, **Factory Defaults**, **Backup & Restore**, **Reboot**, **Password**, **System Log** and

**Statistics.** Click any of them, and you will be able to configure the corresponding function. The detailed explanations for each submenu are provided below.

### 4.18.1 Time Settings

You can set time manually or get GMT from the Internet for the router on this page:

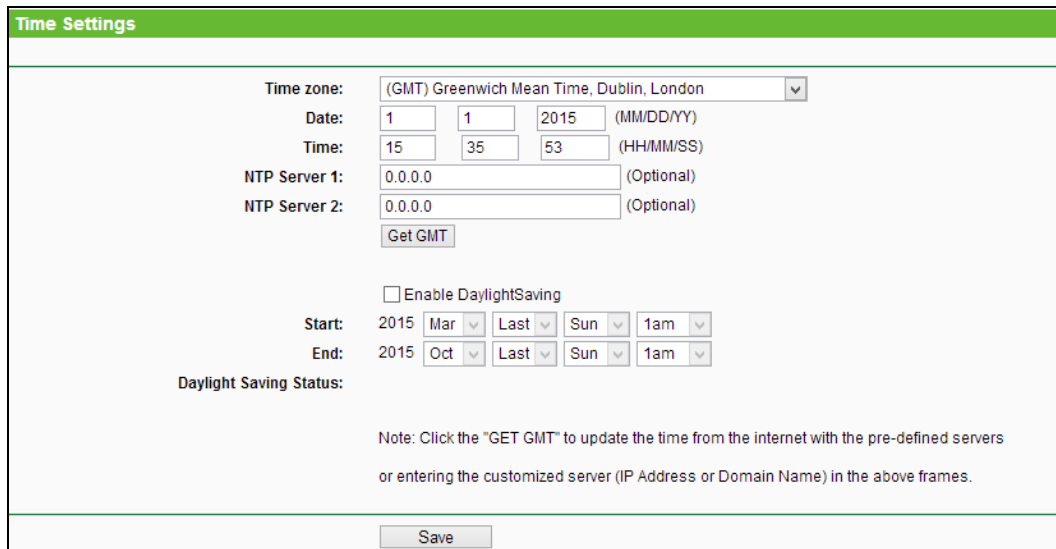

Figure 4-85 Time Settings

- **Time Zone** - Select your local time zone from this pull-down list.
- **Date** - Enter your local date in MM/DD/YY into the right blanks.
- **Time** - Enter your local time in HH/MM/SS into the right blanks.

To set time manually, follow the steps below:

1. Select your local time zone.
2. Enter the **Date** in Month/Day/Year format.
3. Enter the **Time** in Hour/Minute/Second format.
4. Click **Save**.

For automatic time synchronization:

1. Enter the address of the **NTP Server 1** or **NTP Server 2**.
2. Click the **Get GMT** button to get GMT time from Internet if you have connected to Internet.

 **Note:**

This setting will be used for some time-based functions such as firewall. You must specify your time zone once you login to the router successfully, if not, the time limited on these functions will not take effect.

- The time will be lost if the router is turned off.
- The router will obtain GMT automatically from Internet if it has already connected to Internet.



## 4.18.2 Diagnostic

Choose menu “**System Tools** → **Diagnostic**”, you can transact Ping or Traceroute function to check connectivity of your network in the following screen.

**Diagnostic Tools**

**Diagnostic Parameters**

Diagnostic Tool:  Ping  Traceroute

IP Address/ Domain Name:

Ping Count:  (1-50)

Ping Packet Size:  (4-1472 Bytes)

Ping Timeout:  (100-2000 Milliseconds)

Traceroute Max TTL:  (1-30)

**Diagnostic Results**

This device is ready.

Start

Figure 4-86 Diagnostic Tools

- **Diagnostic Tool** - Check the radio button to select one diagnostic tool.
  - **Ping** - This diagnostic tool troubleshoots connectivity, reachability, and name resolution to a given host or gateway.
  - **Traceroute** - This diagnostic tool tests the performance of a connection.

 **Note:**

You can use ping/traceroute to test both numeric IP address or domain name. If pinging/tracerouting the IP address is successful, but pinging/tracerouting the domain name is not, you might have a name resolution problem. In this case, ensure that the domain name you are specifying can be resolved by using Domain Name System (DNS) queries.

- **IP Address/Domain Name** - Type the destination IP address (such as 202.108.22.5) or Domain name (such as www.baidu.com).
- **Pings Count** - The number of Ping packets for a Ping connection.
- **Ping Packet Size** - The size of Ping packet.
- **Ping Timeout** - Set the waiting time for the reply of each Ping packet. If there is no reply in the specified time, the connection is overtime.
- **Traceroute Max TTL** - The max number of hops for a Traceroute connection.

Click **Start** to check the connectivity of the Internet.

The **Diagnostic Results** page displays the result of diagnosis.

If the result is similar to the following screen, the connectivity of the Internet is fine.

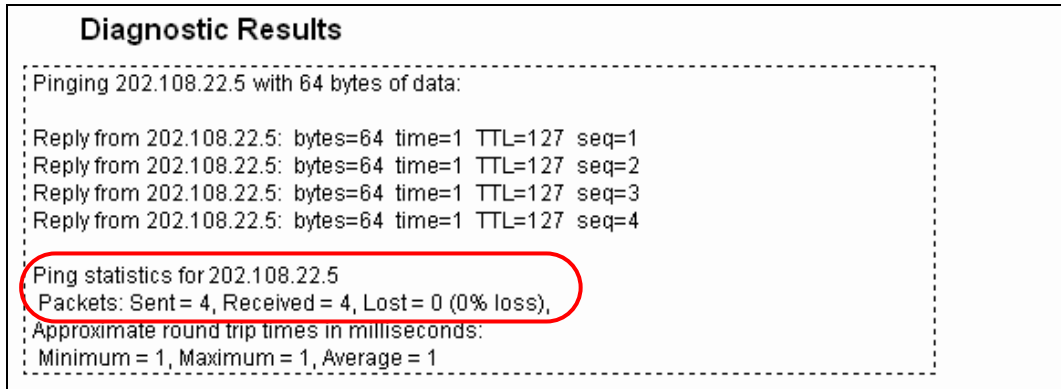

Figure 4-87 Diagnostic Results

**Note:**

Only one user can use this tool at one time. "Ping Count", "Ping Packet Size" and "Ping Timeout" are Ping Parameters. "Traceroute Max TTL" is Traceroute Parameter.

### 4.18.3 Firmware Upgrade

The page allows you to upgrade the latest version firmware to keep your router up-to-date.

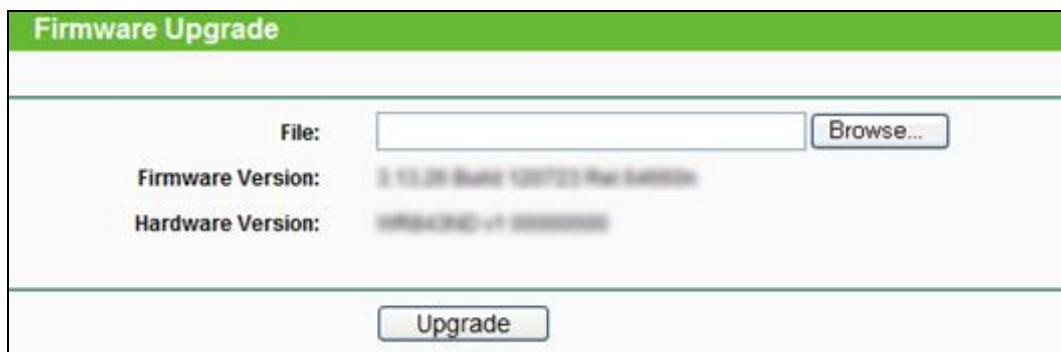

Figure 4-88 Firmware Upgrade

New firmware is posted at [www.tp-link.com](http://www.tp-link.com) and can be downloaded for free. If the router is not experiencing difficulties, there is no need to upgrade firmware, unless the new firmware supports a new feature you need.

**Note:**

1. When you upgrade the router's firmware, you will lose current configuration settings, so make sure you backup the router's settings before you upgrade its firmware.
2. Make sure that your computer is connected to the Internet through the cable when you upgrade the firmware. To upgrade through wireless connection is not allowed.
3. Set your IP address as static IP before upgrading.

To upgrade the router's firmware, follow these instructions:

1. Download the latest firmware upgrade file from our website <http://www.tp-link.com>.
  2. Enter or select the path name where you save the downloaded file on the computer into the **File** blank.
  3. Click the **Upgrade** button.
- **Firmware Version** - Displays the current firmware version.
  - **Hardware Version** - Displays the current hardware version. The hardware version of the upgrade file must accord with the current hardware version.

 **Note:**

The firmware version must correspond to the hardware. The upgrade process takes a few minutes and the Router will restart automatically when the upgrade is completed. It is important to keep power on during the entire process. Loss of power during the upgrade could damage the Router.

#### 4.18.4 Factory Defaults

This page allows you to restore the factory default settings for the router.

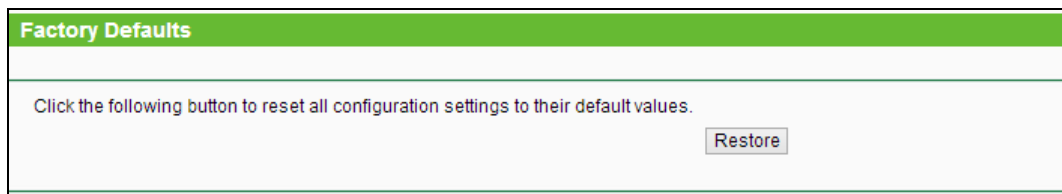

Figure 4-89 Restore Factory Default

Click the **Restore** button to reset all configuration settings to their default values.

- The default User Name: admin
- The default Password: admin
- The default access: tplinkwifi.net

 **Note:**

Any settings you have saved will be lost when the default settings are restored.

#### 4.18.5 Backup & Restore

This page allows you to save current configuration of router as backup or restore the configuration file you saved before.

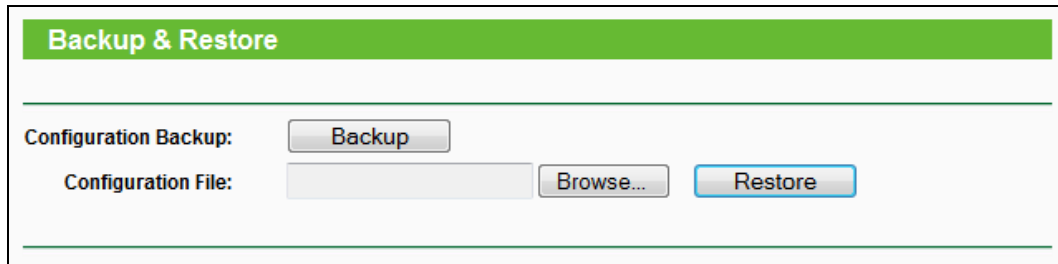

Figure 4-90 Backup & Restore Configuration

- Click the **Backup** button to save all configuration settings as a backup file in your local computer.
- To restore the router's configuration, follow these instructions:
  - Click the **Browse** button to select the backup file which you want to restore.
  - Click the **Restore** button.

 **Note:**

The current configuration will be covered with the uploading configuration file. The restoration process lasts for 20 seconds and the router will restart automatically. Keep the router on during the restoring process to prevent any damage.

#### 4.18.6 Reboot

This page allows you to reboot the router.

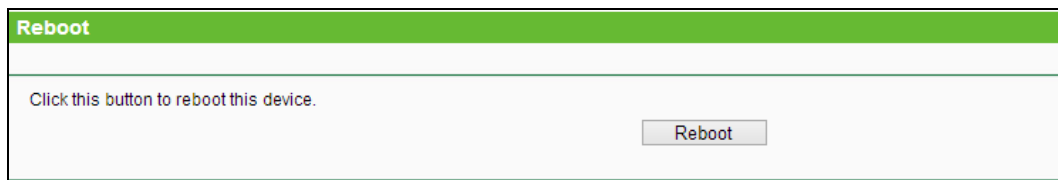

Figure 4-91 Reboot the router

Click the **Reboot** button to reboot the router.

Some settings of the router will take effect only after rebooting, which include:

- Change LAN IP Address. (System will reboot automatically)
- MAC Clone (system will reboot automatically)
- DHCP service function.
- Static address assignment of DHCP server.
- Web Service Port of the router.
- Upgrade the firmware of the router (system will reboot automatically).
- Restore the router's settings to factory default (system will reboot automatically).

### 4.18.7 Password

This page allows you to change the factory default user name and password of the router.

Figure 4-92 Password

It is recommended strongly that you change the factory default user name and password of the router. All users who try to access the router's Web-based utility or Quick Setup will be prompted

#### Note:

The new user name and password must not exceed 14 characters in length and must not include any spaces. Enter the new Password twice to confirm it.

Click the **Save** button when finished.

Click the **Clear All** button to clear all.

### 4.18.8 System Log

This page allows you to query the logs of the router.

Figure 4-93 System Log

- **Refresh** - Refresh the page to show the latest log list.
- **Save Log** - Click to save all the logs in a txt file.
- **Mail Log** - Click to send an email of current logs manually according to the address and validation information set in Mail Settings. The result will be shown in the later log soon.
- **Clear Log** - All the logs will be deleted from this device permanently, not just from the page.

### 4.18.9 Statistics

The Statistics page displays the network traffic of each PC in LAN, including total traffic and traffic of the last **Packets Statistic interval** seconds.

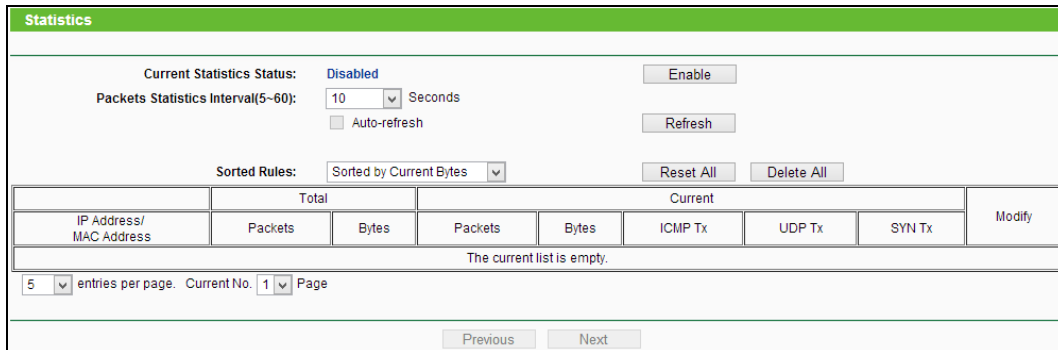

Figure 4-94 Statistics

- **Current Statistics Status** - Enable or Disable. The default value is disabled. To enable, click the **Enable** button. If disabled, the function of DoS protection in Security settings will be ineffective.
- **Packets Statistics Interval** - The default value is 10. Select a value between 5 and 60 seconds in the pull-down list. The Packets Statistic interval indicates the time section of the packets statistic.
- **Sorted Rules** - Here displays sort as desired.

**Statistics Table:**

IP Address		The IP Address displayed with statistics
<b>Total</b>	<b>Packets</b>	The total amount of packets received and transmitted by the router.
	<b>Bytes</b>	The total amount of bytes received and transmitted by the router.
<b>Current</b>	<b>Packets</b>	The total amount of packets received and transmitted in the last <b>Packets Statistic interval</b> seconds.
	<b>Bytes</b>	The total amount of bytes received and transmitted in the last <b>Packets Statistic interval</b> seconds.
	<b>ICMP Tx</b>	The total amount of the ICMP packets transmitted to WAN in the last <b>Packets Statistic interval</b> seconds.
	<b>UDP Tx</b>	The total amount of the UDP packets transmitted to WAN in the last <b>Packets Statistic interval</b> seconds.
	<b>TCP SYN Tx</b>	The total amount of the TCP SYN packets transmitted to WAN in the last <b>Packets Statistic interval</b> seconds.

Click the **Save** button to save the **Packets Statistic interval** value.

Click the **Auto-refresh** checkbox to refresh automatically.

Click the **Refresh** button to refresh immediately.

## Chapter 5. Configuration for Access Point Mode

This chapter will show each Web page's key functions and the configuration way for Access Point Mode of TL-WR810N.

### 5.1 Login

After your successful login, you can configure and manage the device. There are main menus on the left of the web-based utility. Submenus will be available after you click one of the main menus. On the right, there are the corresponding explanations and instructions.



Status
Quick Setup
WPS
Working Mode
Network
Wireless
DHCP
USB Settings
System Tools
Logout

Figure 5-1

The detailed explanations for each Web page's key function are listed below.

### 5.2 Status

The Status page provides the current status information about the Router on Access Point Mode. All information is read-only.

Status		
Firmware Version:	3.10.5 Build 150810 Rev.424526	
Hardware Version:	WR810N v1 00000000	
<b>Wired</b>		
MAC Address:	00-0A-EB-13-09-19	
IP Address:	192.168.0.254	
Subnet Mask:	255.255.255.0	
<b>Wireless</b>		
Working Mode:	<a href="#">Access Point</a>	
Wireless Network Name:	TP-LINK_0919	
Channel:	Auto (Current channel 8)	
Mode:	11bgn mixed	
Channel Width:	Automatic	
Max Tx Rate:	300Mbps	
MAC Address:	00-0A-EB-13-09-19	
<b>Traffic Statistics</b>		
	Received	Sent
Bytes:	0	0
Packets:	0	0
System Up Time:	0 days 00:06:30	
		<input type="button" value="Refresh"/>

Figure 5-2 Status

- **Firmware Version** - The version information of the Router's firmware.
- **Hardware Version** - The version information of the Router's hardware.
- **Wired** - This field displays the current settings or information for the LAN, you can configure them in the **Network > LAN** page.
  - **MAC address** - The physical address of the Router, as seen from the LAN.
  - **IP address** - The LAN IP address of the Router.
  - **Subnet Mask** - The subnet mask associated with LAN IP address.
- **Wireless** - This field displays basic information or status for wireless function, you can configure them in the **Wireless > Wireless Settings** page.
  - **Working Mode** - The current wireless working mode in use.
  - **Wireless Network Name** - The SSID of the AP.
  - **Channel** - The current wireless channel in use.
  - **Mode** - The current wireless mode which the Router works on.
  - **Channel Width** - The current wireless channel width in use.
  - **MAC Address** - The physical address of the Router, as seen from the WLAN.
- **Traffic Statistics** - The Router's traffic statistics.



- **Received (Bytes)** - Traffic that counted in bytes has been received out from the WAN port.
  - **Received (Packets)** - Traffic that counted in packets has been received out from the WAN port.
  - **Sent (Bytes)** - Traffic that counted in bytes has been sent out from the WAN port.
  - **Sent (Packets)** - Traffic that counted in packets has been sent out from the WAN port.
- **System Up Time** - The length of the time since the Router was last powered on or reset.

Click the **Refresh** button to get the latest status and settings of the Router.

## 5.3 Quick Setup

Please refer to [Section 3.2: Quick Installation Guide](#).

## 5.4 WPS

**WPS (Wi-Fi Protected Setup)** can help you to quickly and securely connect to a network. This section will guide you to add a new wireless device to an existing network quickly by function. The WPS function is only available when the Operation Mode is set to Access Point. Select menu “**WPS**”, you will see the next screen shown in Figure 5-3.

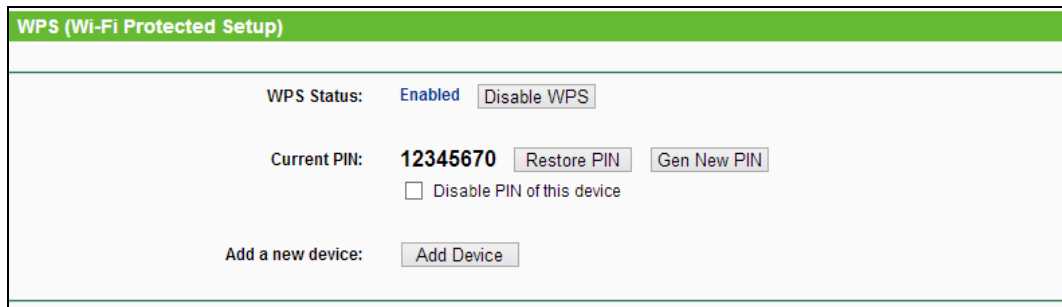

WPS (Wi-Fi Protected Setup)

WPS Status: **Enabled**

Current PIN: **12345670**

Disable PIN of this device

Add a new device:

Figure 5-3 WPS

- **WPS Status** - To enable or disable the WPS function here.
- **Current PIN** - The current value of the device's PIN is displayed here. The default PIN of the device can be found in the label or User Guide.
- **Restore PIN** - Restore the PIN of the device to its default.
- **Gen New PIN** - Click this button, and then you can get a new random value for the device's PIN. You can ensure the network security by generating a new PIN.
- **Disable PIN of this Device** - WPS external registrar of entering the device's PIN can be disabled or enabled manually. If the device receives multiple failed attempts to authenticate an external Registrar, this function will be disabled automatically.
- **Add Device** - You can add a new device to the existing network manually by clicking this button.

**To add a new device:**

If the wireless adapter supports Wi-Fi Protected Setup (WPS), you can establish a wireless connection between wireless adapter and device using either Push Button Configuration (PBC) method or PIN method.

**Note:**

To build a successful connection by WPS, you should also do the corresponding configuration of the new device for WPS function meanwhile.

For the configuration of the new device, here takes the Wireless Adapter of our company for example.

**II. By PBC**

If the wireless adapter supports Wi-Fi Protected Setup and the Push Button Configuration (PBC) method, you can add it to the network by PBC with the following two methods.

**Method One:**

Step 1: Keep the WPS Status as **Enabled** and click the **Add Device** button in Figure 5-3, then the following screen will appear.

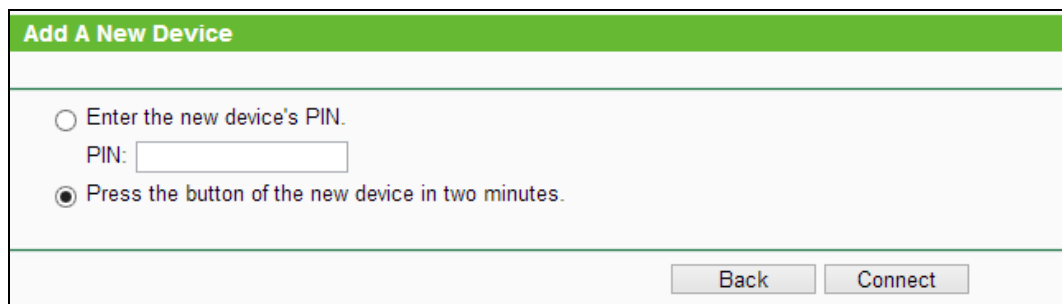
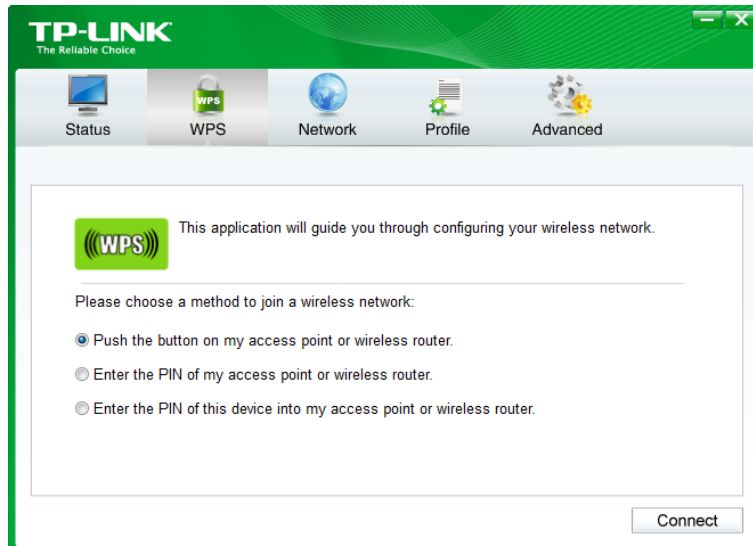

Figure 5-4 Add A New Device

Step 2: Choose “**Press the button of the new device in two minutes**” and click **Connect**.

Step 3: For the configuration of the wireless adapter, please choose “**Push the button on my access point or wireless router**” in the configuration utility of the WPS as below, and click **Connect**.



The WPS Configuration Screen of Wireless Adapter

Step 4: Wait for a while until the next screen appears. Click **OK** to complete the WPS configuration.



The WPS Configuration Screen of Wireless Adapter

**Method Two:** Enter the PIN into my AP

Step 1: For the configuration of the wireless adapter, please choose “**Enter the PIN of this device into my access point or wireless router**” in the configuration utility of the WPS as below, and click **Connect**.



The WPS Configuration Screen of Wireless Adapter

**Note:**

In this example, the default PIN code of this adapter is 16952898 as the above figure shown.

Step 2: Keep the WPS Status as **Enabled** and click the **Add Device** button in Figure 5-3.

Step 3: Choose “**Enter the new device's PIN**” and enter the PIN code (take 16952898 for example) of the wireless adapter in the field after **PIN** as shown in the figure below. Then click **Connect**.

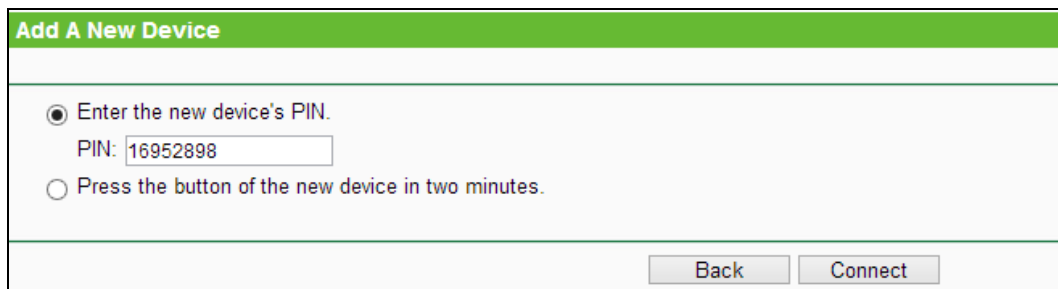

Figure 5-5 Add A New Device

**Method Three:** Enter the PIN from my AP

Step 1: Get the Current PIN code of the AP in Figure 5-3 (each AP has its unique PIN code. Here takes the PIN code 12345670 of this AP for example).

Step 2: For the configuration of the wireless adapter, please choose “**Enter the PIN of my access point or wireless router**” in the configuration utility of the WPS as below, and enter the PIN code of the AP into the field after “**Access Point PIN**”. Then click **Connect**.



The WPS Configuration Screen of Wireless Adapter

**Note:**

The default PIN code of the AP can be found in its label or the WPS configuration screen.

You will see the **Connect successfully** screen when the new device has successfully connected to the network.

**Note:**

- 1) The WPS LED on the AP will light green for five minutes if the device has been successfully added to the network.
- 2) The WPS function cannot be configured if the Wireless function of the AP is disabled. Please make sure the Wireless function is enabled before configuring the WPS.

## 5.5 Working Mode

The Router supports five operation mode types: **Wireless Router**, **Access Point**, **Repeater**, **Client** and **Wireless Client Router**. Please select one you want. Click **Save** to save your choice, which is shown as Figure 5-6.

Working Mode	
<input type="radio"/> Standard Wireless Router	- Enable multiple users to share Internet connection via ADSL/Cable Modem
<input checked="" type="radio"/> Access Point	- Transform your existing wired network to a wireless network
<input type="button" value="Save"/>	

Figure 5-6 Working Mode Settings

- **Standard Wireless Router** - In this mode, the device enables multiple users to share the Internet connection via ADSL/Cable Modem. The LAN devices share the same IP from ISP through Wireless port. While connecting to Internet, the LAN/WAN Ethernet port works as a WAN port at Standard Wireless Router mode.

- **Access Point** - In this mode, this device can be connected to a wired network and transform the wired access into wireless that multiple devices can share together, especially for a home, office or hotel where only wired network is available.

## 5.6 Network



Figure 5-7 The Network menu

There is only one submenu under the Network menu (shown in Figure 5-7): **LAN**.

### 5.6.1 LAN

Choose menu “**Network** → **LAN**”, and then you can configure the IP parameters of the LAN on the screen as below.

The screenshot shows the LAN configuration interface. It has a green header 'LAN'. Below it, there are fields for 'MAC Address: 00-0A-EB-13-09-19', 'Type: Smart IP(DHCP)', 'IP Address: 192.168.0.254', 'Subnet Mask: 255.255.255.0', and 'Gateway: 0.0.0.0'. There is a checkbox for 'Allow remote access' which is unchecked. A note at the bottom states: 'Note: The IP parameters cannot be configured if you have chosen Smart IP (DHCP) (In this situation the device will help you configure the IP parameters automatically as you need)'. A 'Save' button is at the bottom.

Figure 5-8 LAN

- **MAC Address** - The physical address of the LAN ports, as seen from the LAN. The value can not be changed.
- **Type** - Choosing Smart IP (DHCP) to get IP address from DHCP server, or choosing static IP to config IP address manually.
- **IP Address** - Enter the IP address of your system in dotted-decimal notation (factory default - 192.168.0.254).
- **Subnet Mask** - An address code that determines the size of the network. Normally 255.255.255.0 is used as the subnet mask.
- **Gateway** - The gateway should be in the same subnet as your IP address.
- **Allow remote access** - Allow remote devices to access the AP device by inputting the IP address in browser.

#### **Note:**

1. If you change the IP address, you must use the new IP address to login the system.

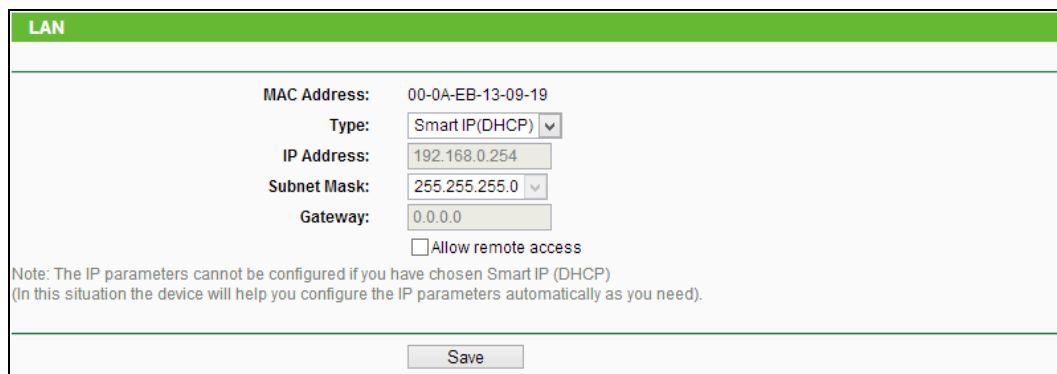
2. If you select the type of Smart IP (DHCP), the DHCP server in this device will not startup.
3. If the new IP address you set is not in the same subnet, the IP Address pool in the DHCP server will not take effect, until they are re-configured.
4. This device will reboot automatically after you click the **Save** button.

Click the **Save** button to save your settings.

 **Note:**

When you choose the Smart IP (DHCP) mode, the DHCP Server function will be disabled.

## 5.7 Wireless

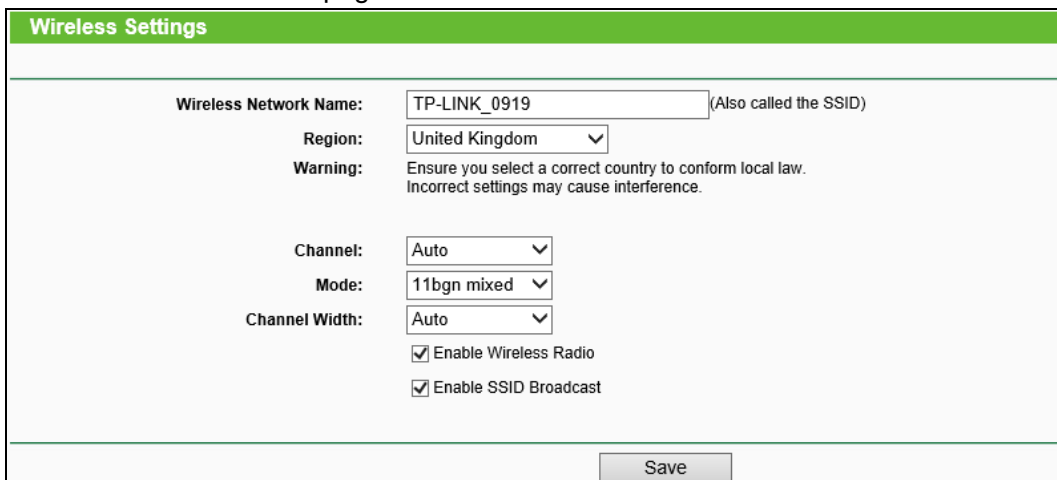

Figure 5-9 Wireless menu

There are six submenus under the Wireless menu (shown in Figure 5-9): **Wireless Settings**, **Wireless Security**, **Wireless MAC Filtering**, **Wireless Advanced**, **Wireless Statistics** and **Throughput Monitor**. Click any of them, and you will be able to configure the corresponding function.

### 5.7.1 Wireless Settings

Choose menu “**Wireless** → **Wireless Settings**”, and then you can configure the basic settings for the wireless network on this page.



Wireless Settings	
Wireless Network Name:	<input type="text" value="TP-LINK_0919"/> (Also called the SSID)
Region:	<input type="text" value="United Kingdom"/>
Warning:	Ensure you select a correct country to conform local law. Incorrect settings may cause interference.
Channel:	<input type="text" value="Auto"/>
Mode:	<input type="text" value="11bgn mixed"/>
Channel Width:	<input type="text" value="Auto"/>
	<input checked="" type="checkbox"/> Enable Wireless Radio
	<input checked="" type="checkbox"/> Enable SSID Broadcast
<input type="button" value="Save"/>	

Figure 5-10 Wireless Settings - AP

- **Wireless Network Name** - Enter a string of up to 32 characters. The same name of SSID (Service Set Identification) must be assigned to all wireless devices in your network. The default SSID is set to be TP-LINK\_XXXX (XXXX indicates the last unique four numbers of each Router's MAC address). But it is recommended strongly that you change your networks name (SSID) to a different value. This value is case-sensitive. For example, *TEST* is NOT the same as *test*.
- **Region** - Select your region from the pull-down list. This field specifies the region where the wireless function of the Router can be used. It may be illegal to use the wireless function of the Router in a region other than one of those specified in this field. If your country or region is not listed, please contact your local government agency for assistance.
- **Channel** - This field determines which operating frequency will be used. The default channel is set to **Auto**. It is not necessary to change the wireless channel unless you notice interference problems with another nearby access point.
- **Mode** - Select the desired mode. The default setting is 11bgn mixed.
  - **11bg mixed** - Select if you are using both 802.11b and 802.11g wireless clients.
  - **11bgn mixed** - Select if you are using a mix of 802.11b, 11g, and 11n wireless clients.

When 11bg mixed mode is selected, only 11bg mixed wireless stations can connect to the Router. It is strongly recommended that you set the Mode to 11bgn mixed, and all of 802.11b/g/n wireless stations can connect to the Router.

 **Note:**

If **11bg mixed mode** is selected in the **Mode** field, the **Channel Width** selecting field will turn grey and the value will become 20M, which is unable to be changed.

- **Channel Width** - Select any channel width from the pull-down list. The default setting is automatic, which can automatically adjust the channel width for your clients.
- **Enable Wireless Radio** - The wireless radio of the Router can be enabled or disabled to allow wireless stations access. If enabled, the wireless stations will be able to access the Router. Otherwise, wireless stations will not be able to access the Router.
- **Enable SSID Broadcast** - If you select the **Enable SSID Broadcast** checkbox, the wireless router will broadcast its name (SSID) on the air.

Be sure to click the **Save** button to save your settings on this page.

 **Note:**

1. The operating distance or range of your wireless connection varies significantly based on the physical placement of the Router. For best results, place your Router.
  - Near the center of the area in which your wireless stations will operate.
  - In an elevated location such as a high shelf.



- Away from the potential sources of interference, such as PCs, microwaves, and cordless phones.
  - Away from large metal surfaces.
2. Failure to follow these guidelines can result in significant performance degradation or inability to wirelessly connect to the Router.

### 5.7.2 Wireless Security

Choose menu “**Wireless** → **Wireless Security**”, and then you can configure the security settings of your wireless network.

There are three wireless security modes supported by the Router: WPA/WPA2-Personal, WPA/WPA2-Enterprise and WEP (Wired Equivalent Privacy).

Figure 5-11 Wireless Security

- **Disable Security** - The wireless security function can be enabled or disabled. If disabled, the wireless stations will be able to connect the Router without encryption. But it's strongly recommended to choose one of the following modes to enable security.
- **WPA-PSK/WPA2-Personal** - It's the WPA/WPA2 authentication type based on pre-shared passphrase.
  - **Version** - you can choose the version of the WPA-PSK security on the drop-down list. The default setting is **Automatic**, which can select **WPA-PSK** (Pre-shared key of WPA) or **WPA2-PSK** (Pre-shared key of WPA) automatically based on the wireless station's capability and request.

- **Encryption** - When **WPA-PSK** or **WPA** is set as the Authentication Type, you can select either **Automatic**, or **TKIP** or **AES** as Encryption.
- **Wireless Password** - You can enter ASCII or Hexadecimal characters. For Hexadecimal, the length should be between 8 and 64 characters; for ASCII, the length should be between 8 and 63 characters.
- **Group Key Update Period** - Specify the group key update interval in seconds. The value can be either 0 or at least 30. Enter 0 to disable the update.

 **Note:**

If you check the **WPA/WPA2-Personal** radio button and choose TKIP encryption, you will find a notice in red.

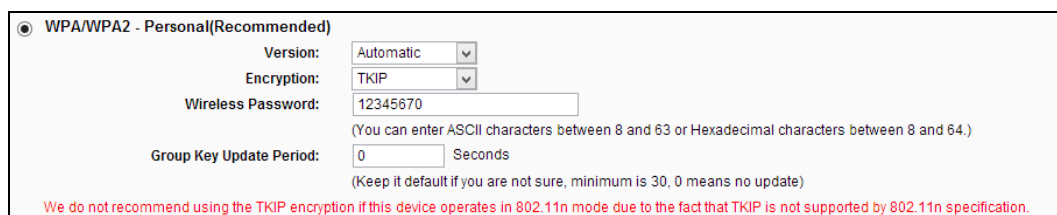

WPA/WPA2 - Personal(Recommended)

Version: Automatic

Encryption: TKIP

Wireless Password: 12345670  
(You can enter ASCII characters between 8 and 63 or Hexadecimal characters between 8 and 64.)

Group Key Update Period: 0 Seconds  
(Keep it default if you are not sure, minimum is 30, 0 means no update)

We do not recommend using the TKIP encryption if this device operates in 802.11n mode due to the fact that TKIP is not supported by 802.11n specification.

➤ **WPA /WPA2-Enterprise** - It's based on Radius Server.

- **Version** - you can choose the version of the WPA security from the pull-down list. The default setting is **Automatic**, which can select **WPA** (Wi-Fi Protected Access) or **WPA2** (WPA version 2) automatically based on the wireless station's capability and request.
- **Encryption** - You can select **Automatic**, **TKIP** or **AES**.
- **Radius Server IP** - Enter the IP address of the Radius server.
- **Radius Port** - Enter the port that Radius server used.
- **Radius Password** - Enter the password for the Radius server.
- **Group Key Update Period** - Specify the group key update interval in seconds. The value should be 30 or above. Enter 0 to disable the update.

➤ **WEP** - It is based on the IEEE 802.11 standard.

- **Type** - you can choose the type for the WEP security on the pull-down list. The default setting is **Automatic**, which can select **Shared Key** or **Open System** authentication type automatically based on the wireless station's capability and request.
- **WEP Key Format** - **Hexadecimal** and **ASCII** formats are provided here. **Hexadecimal** format stands for any combination of hexadecimal digits (0-9, a-f, A-F) in the specified length. **ASCII** format stands for any combination of keyboard characters in the specified length.

- **WEP Key (Password)** - Select which of the four keys will be used and enter the matching WEP key that you create. Make sure these values are identical on all wireless stations in your network.
- **Key Type** - You can select the WEP key length (64-bit, or 128-bit, or 152-bit.) for encryption. "Disabled" means this WEP key entry is invalid.
  - 64-bit** - You can enter 10 hexadecimal digits (any combination of 0-9, a-f, A-F, and null key is not permitted) or 5 ASCII characters.
  - 128-bit** - You can enter 26 hexadecimal digits (any combination of 0-9, a-f, A-F, and null key is not permitted) or 13 ASCII characters.
  - 152-bit** - You can enter 32 hexadecimal digits (any combination of 0-9, a-f, A-F, and null key is not permitted) or 16 ASCII characters.

 **Note:**

If you do not set the key, the wireless security function is still disabled even if you have selected Shared Key as Authentication Type.

### 5.7.3 Wireless MAC Filtering

Choose menu “**Wireless** → **Wireless MAC Filtering**”, and then you can control the wireless access by configuring the **Wireless MAC Filtering** function, as shown in Figure 5-12.

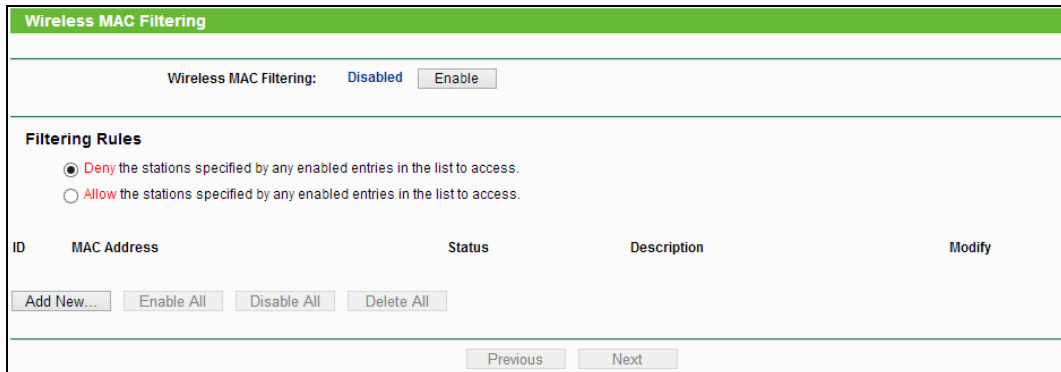
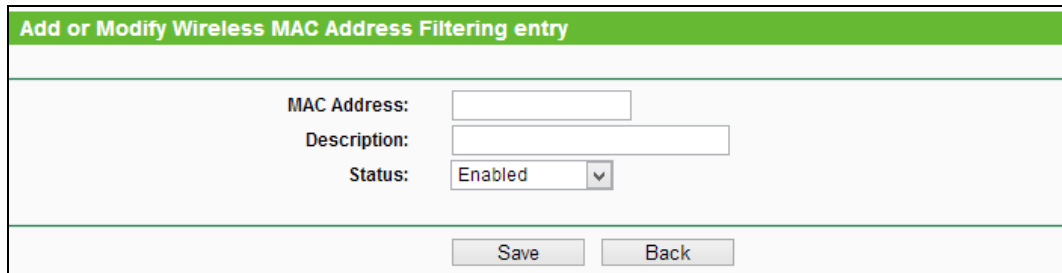

Figure 5-12 Wireless MAC Filtering

To filter wireless users by MAC Address, click **Enabled**. The default setting is **Disabled**.

- **MAC Address** - The wireless station's MAC address that you want to access.
- **Status** - The status of this entry, either **Enabled** or **Disabled**.
- **Description** - A simple description of the wireless station.

To Add a Wireless MAC Address filtering entry, click the **Add New...** button. The "**Add or Modify Wireless MAC Address Filtering entry**" page will appear, shown in Figure 5-13:



Add or Modify Wireless MAC Address Filtering entry	
MAC Address:	<input type="text"/>
Description:	<input type="text"/>
Status:	Enabled <input type="button" value="v"/>
<input type="button" value="Save"/> <input type="button" value="Back"/>	

Figure 5-13 Add or Modify Wireless MAC Address Filtering entry

**To add or modify a MAC Address Filtering entry, follow these instructions:**

1. Enter the appropriate MAC Address into the **MAC Address** field. The format of the MAC Address is XX-XX-XX-XX-XX-XX (X is any hexadecimal digit). For example: 00-0A-EB-B0-00-0B.
2. Give a simple description for the wireless station in the **Description** field. For example: Wireless station A.
3. Select **Enabled** or **Disabled** for this entry on the **Status** pull-down list.
4. Click the **Save** button to save this entry.

**To modify an existing entry:**

1. Click the **Modify** in the entry you want to modify.
2. Modify the information.
3. Click the **Save** button.

Click the **Delete** in the entry you want to delete to delete an existing entry.

Click the **Enable All** button to make all entries enabled

Click the **Disable All** button to make all entries disabled.

Click the **Delete All** button to delete all entries.

Click the **Next** button to go to the next page.

Click the **Previous** button to return to the previous page.

**For example:** If you desire that the wireless station A with MAC address 00-0A-EB-B0-00-0B and the wireless station B with MAC address 00-0A-EB-00-07-5F are able to access the Router, but all the other wireless stations cannot access the Router, you can configure the **Wireless MAC Address Filtering** list by following these steps:

1. Click the **Enable** button to enable this function.
2. Select the radio button "Allow the stations specified by any enabled entries in the list to access" for **Filtering Rules**.
3. Delete all or disable all entries if there are any entries already.
4. Click the **Add New...** button.

- Enter the MAC address 00-0A-EB-B0-00-0B/00-0A-EB-00-07-5F in the **MAC Address** field.
- Enter wireless station A/B in the **Description** field.
- Select **Enabled** in the **Status** pull-down list.
- Click the **Save** button.
- Click the **Back** button.

The filtering rules that configured should be similar to the following list:

Filtering Rules				
<input type="radio"/> Deny the stations specified by any enabled entries in the list to access.				
<input checked="" type="radio"/> Allow the stations specified by any enabled entries in the list to access.				
ID	MAC Address	Status	Description	Modify
1	00-0A-EB-B0-00-0B	Enabled	wireless station A	<a href="#">Modify</a> <a href="#">Delete</a>
2	00-0A-EB-00-07-5F	Enabled	wireless station B	<a href="#">Modify</a> <a href="#">Delete</a>

## 5.7.4 Wireless Advanced

Choose menu "**Wireless** → **Wireless Advanced**", and then you can configure the advanced settings of your wireless network.

Wireless Advanced	
Transmit Power:	High <input type="button" value="v"/>
Beacon Interval :	<input type="text" value="100"/> (40-1000)
RTS Threshold:	<input type="text" value="2346"/> (256-2346)
Fragmentation Threshold:	<input type="text" value="2346"/> (256-2346)
DTIM Interval:	<input type="text" value="1"/> (1-255)
	<input checked="" type="checkbox"/> Enable WMM
	<input checked="" type="checkbox"/> Enable Short GI
	<input type="checkbox"/> Enable AP Isolation
<input type="button" value="Save"/>	

Figure 5-14 Wireless Advanced

- **Transmit Power** - Here you can specify the transmit power of Router. You can select High, Middle or Low which you would like. High is the default setting and is recommended.
- **Beacon Interval** - Enter a value between 20-1000 milliseconds for Beacon Interval here. The beacons are the packets sent by the Router to synchronize a wireless network. Beacon Interval value determines the time interval of the beacons. The default value is 100.
- **RTS Threshold** - Here you can specify the RTS (Request to Send) Threshold. If the packet is larger than the specified RTS Threshold size, the Router will send RTS frames to a particular receiving station and negotiate the sending of a data frame. The default value is 2346.
- **Fragmentation Threshold** - This value is the maximum size determining whether packets will be fragmented. Setting the Fragmentation Threshold too low may result in poor network

performance because of excessive packets. 2346 is the default setting and is recommended.

- **DTIM Interval** - This value determines the interval of the Delivery Traffic Indication Message (DTIM). A DTIM field is a countdown field informing clients of the next window for listening to broadcast and multicast messages. When the Router has buffered broadcast or multicast messages for associated clients, it sends the next DTIM with a DTIM Interval value. You can specify the value between 1-255 Beacon Intervals. The default value is 1, which indicates the DTIM Interval is the same as Beacon Interval.
- **Enable WMM - WMM** function can guarantee the packets with high-priority messages being transmitted preferentially. It is strongly recommended enabled.
- **Enable Short GI** - This function is recommended for it will increase the data capacity by reducing the guard interval time.
- **Enable AP Isolation** - This function isolate all connected wireless stations so that wireless stations cannot access each other through WLAN. This function will be disabled if WDS/Bridge is enabled.

 **Note:**

If you are not familiar with the setting items in this page, it's strongly recommended to keep the provided default values; otherwise it may result in lower wireless network performance.

### 5.7.5 Wireless Statistics

Choose menu “**Wireless** → **Wireless Statistics**”, and then you can see the MAC Address, Current Status, Received Packets and Sent Packets for each connected wireless station.

Wireless Statistics					
Current Connected Wireless Stations numbers: 1					<input type="button" value="Refresh"/>
ID	MAC Address	Current Status	Received Packets	Sent Packets	Configure
1	70-73-CB-1F-C8-C9	STA-ASSOC	46	16	<input type="button" value="Allow"/>

Figure 5-15 Wireless Statistics

- **MAC Address** - The connected wireless station's MAC address
- **Current Status** - The connected wireless station's running status, one of **STA-AUTH** / **STA-ASSOC** / **STA-JOINED** / **WPA** / **WPA-PSK** / **WPA2** / **WPA2-PSK** / **AP-UP** / **AP-DOWN** / **Disconnected**
- **Received Packets** - Packets received by the station

- **Sent Packets** - Packets sent by the station
- **Configure** - The button is used for loading the item to the **Wireless MAC Filtering** list.
  - **Allow** - If the **Wireless MAC Filtering** function enable, allow the station to access.
  - **Deny** - If the **Wireless MAC Filtering** function enable, deny the station to access.

To update this page and to show the current connected wireless stations, click on the **Refresh** button.

If the numbers of connected wireless stations go beyond one page, click the **Next** button to go to the next page and click the **Previous** button to return the previous page.

 **Note:**

This page will be refreshed automatically every 5 seconds.

### 5.7.6 Throughput Monitor

Choose menu “**Wireless** → **Throughput Monitor**”, and then you can see the wireless throughput info.

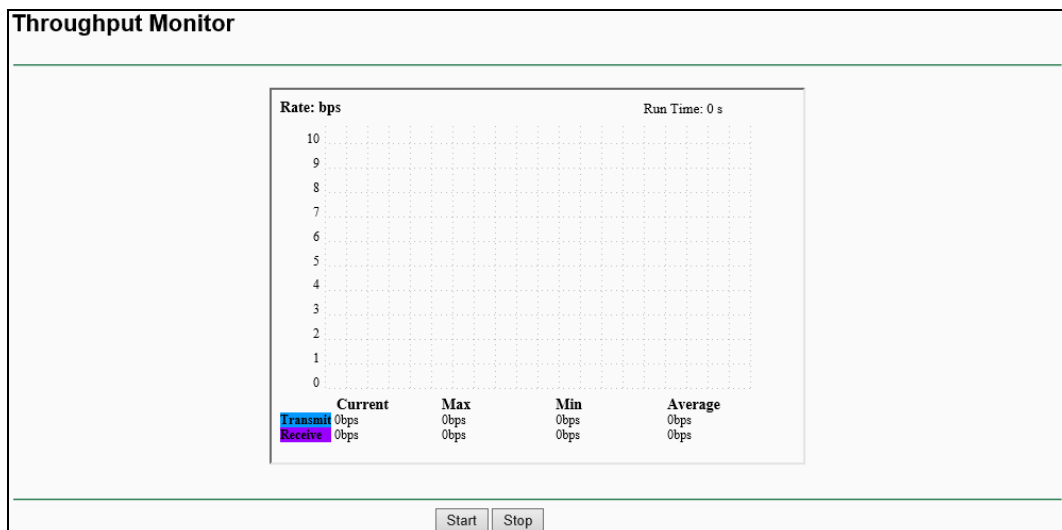

Figure 5-16 Wireless Statistics

- **Rate** - The Throughput unit.
- **Run Time** - How long this function is running.
- **Transmit** - Wireless transmit rate information.
- **Receive** - Wireless receive rate information.

Click the **Start** button to start wireless throughput monitor.

Click the **Stop** button to stop wireless throughput monitor.

## 5.8 DHCP

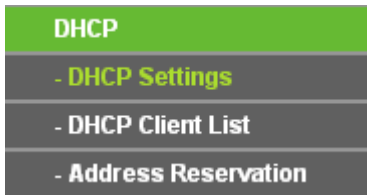

Figure 5-17 The DHCP menu

There are three submenus under the DHCP menu (shown in Figure 5-17), **DHCP Settings**, **DHCP Client List** and **Address Reservation**. Click any of them, and you will be able to configure the corresponding function.

### 5.8.1 DHCP Settings

Choose menu "**DHCP** → **DHCP Settings**", and then you can configure the DHCP Server on the page as shown in Figure 5-18. The Router is set up by default as a DHCP (Dynamic Host Configuration Protocol) server, which provides the TCP/IP configuration for all the PC(s) that are connected to the Router in the LAN.

 A screenshot of a web configuration page titled "DHCP Settings". The page has a green header bar. Below the header, there are several configuration options:
 

- DHCP Server:** Radio buttons for "Disable" and "Enable". The "Enable" option is selected.
- Start IP Address:** A text input field containing "192.168.0.100".
- End IP Address:** A text input field containing "192.168.0.199".
- Address Lease Time:** A text input field containing "120" followed by the text "minutes (1~2880 minutes, the default value is 1 minute)".
- Default Gateway:** A text input field containing "192.168.0.254" with "(Optional)" to its right.
- Default Domain:** An empty text input field with "(Optional)" to its right.
- Primary DNS:** A text input field containing "0.0.0.0" with "(Optional)" to its right.
- Secondary DNS:** A text input field containing "0.0.0.0" with "(Optional)" to its right.

 At the bottom of the form is a "Save" button.

Figure 5-18 DHCP Settings

- **DHCP Server - Enable or Disable** the DHCP server. If you disable the Server, you must have another DHCP server within your network or else you must configure the computer manually.
- **Start IP Address** - Specify an IP address for the DHCP Server to start with when assigning IP addresses. 192.168.0.100 is the default start address.
- **End IP Address** - Specify an IP address for the DHCP Server to end with when assigning IP addresses. 192.168.0.199 is the default end address.
- **Address Lease Time** - The **Address Lease Time** is the amount of time a network user will be allowed connection to the Router with their current dynamic IP Address. Enter the amount of time in minutes and the user will be "leased" this dynamic IP Address. After the



time is up, the user will be automatically assigned a new dynamic IP address. The range of the time is 1 ~ 2880 minutes. The default value is 120 minutes.

- **Default Gateway** (Optional) - It is suggested to input the IP address of the LAN port of the Router. The default value is 192.168.0.254.
- **Default Domain** (Optional) - Input the domain name of your network.
- **Primary DNS** - (Optional) Input the DNS IP address provided by your ISP or consult your ISP.
- **Secondary DNS** (Optional) - Input the IP address of another DNS server if your ISP provides two DNS servers.

 **Note:**

1. To use the DHCP server function of the Router, you must configure all computers on the LAN as "Obtain an IP Address automatically".
2. When you choose the **Smart IP (DHCP)** mode in **Network** → **LAN**, the DHCP Server function will be disabled.

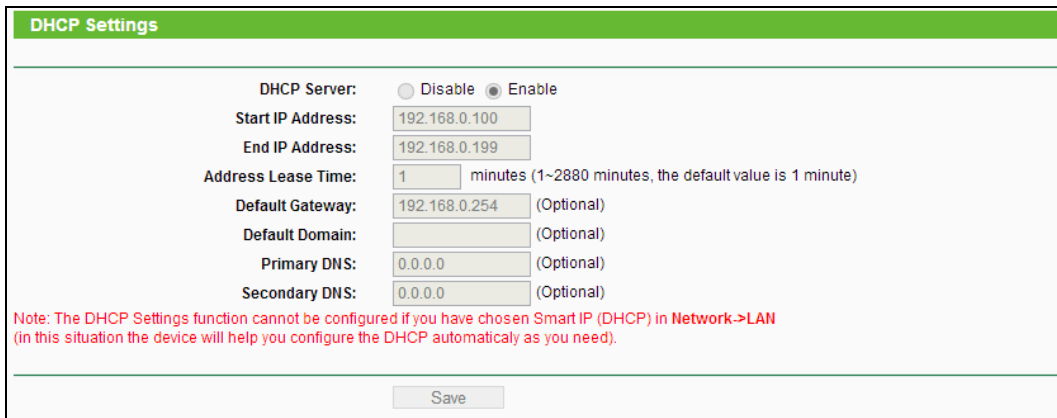

**DHCP Settings**

DHCP Server:  Disable  Enable

Start IP Address:

End IP Address:

Address Lease Time:  minutes (1~2880 minutes, the default value is 1 minute)

Default Gateway:  (Optional)

Default Domain:  (Optional)

Primary DNS:  (Optional)

Secondary DNS:  (Optional)

Note: The DHCP Settings function cannot be configured if you have chosen Smart IP (DHCP) in Network->LAN (in this situation the device will help you configure the DHCP automatically as you need).

Figure 5-19 DHCP Settings

Click the **Save** button to save your settings.

## 5.8.2 DHCP Client List

Choose menu "DHCP → DHCP Clients List", and then you can view the information about the clients attached to the Router in the screen as shown in Figure 5-20.

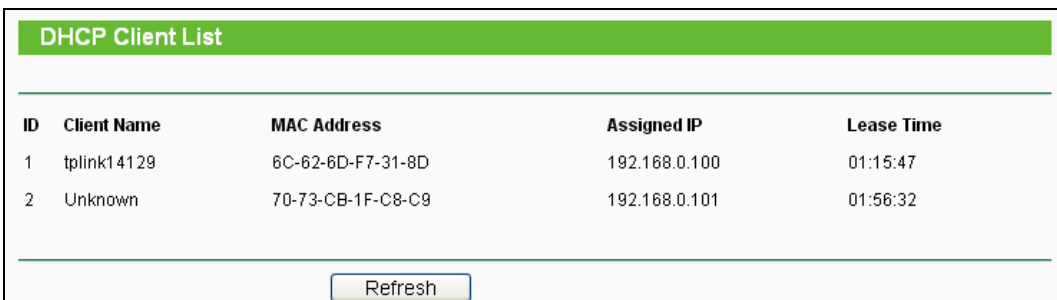

**DHCP Client List**

ID	Client Name	MAC Address	Assigned IP	Lease Time
1	tpplink14129	6C-62-6D-F7-31-8D	192.168.0.100	01:15:47
2	Unknown	70-73-CB-1F-C8-C9	192.168.0.101	01:56:32

Figure 5-20 DHCP Client List

- **Client Name** - The name of the DHCP client
- **MAC Address** - The MAC address of the DHCP client
- **Assigned IP** - The IP address that the Router has allocated to the DHCP client
- **Lease Time** - The time of the DHCP client leased. After the dynamic IP address has expired, a new dynamic IP address will be automatically assigned to the user.

You cannot change any of the values on this page. To update this page and to show the current attached devices, click the **Refresh** button.

### 5.8.3 Address Reservation

Choose menu “**DHCP → Address Reservation**”, and then you can view and add a reserved address for clients via the next screen (shown in Figure 5-21). When you specify a reserved IP address for a PC on the LAN, that PC will always receive the same IP address each time when it accesses the DHCP server. Reserved IP addresses should be assigned to the servers that require permanent IP settings.

Address Reservation				
ID	MAC Address	Reserved IP Address	Status	Modify
1	00-11-22-33-44-AA	192.168.0.169	Enabled	<a href="#">Modify</a> <a href="#">Delete</a>

Figure 5-21 Address Reservation

- **MAC Address** - The MAC address of the PC for which you want to reserve an IP address.
- **Reserved IP Address** - The IP address reserved for the PC by the Router.
- **Status** - The status of this entry either **Enabled** or **Disabled**.
- **Modify** - To modify or delete an existing entry.

#### To Reserve an IP address:

1. Click the **Add New...** button. Then Figure 5-22 will pop-up.
2. Enter the MAC address (in XX-XX-XX-XX-XX-XX format.) and IP address (in dotted-decimal notation) of the computer for which you want to reserve an IP address.
3. Click the **Save** button.

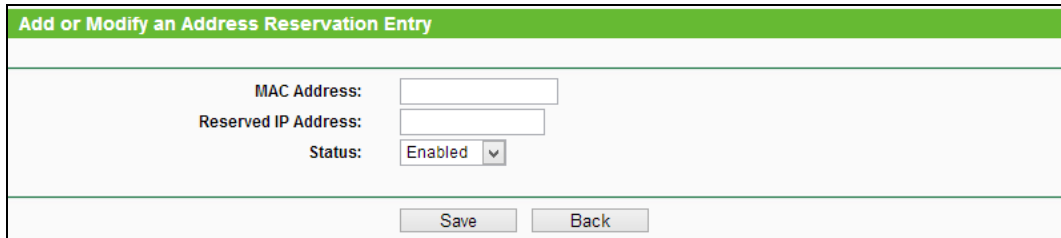

Add or Modify an Address Reservation Entry	
MAC Address:	<input type="text"/>
Reserved IP Address:	<input type="text"/>
Status:	Enabled ▾
<input type="button" value="Save"/> <input type="button" value="Back"/>	

Figure 5-22 Add or Modify an Address Reservation Entry

#### To modify or delete an existing entry:

1. Click the **Modify** in the entry you want to modify. If you want to delete the entry, click the **Delete**.
2. Modify the information.
3. Click the **Save** button.

Click the **Enable/Disable All** button to make all entries enabled/disabled

Click the **Delete All** button to delete all entries.

Click the **Next** button to go to the next page and Click the **Previous** button to return the previous page.

## 5.9 USB Settings

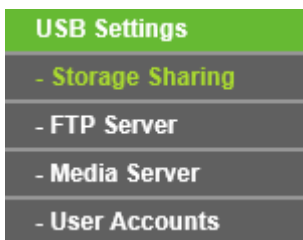

Figure 5-23 The USB Settings menu

There are three submenus under the USB Settings menu (shown in Figure 5-23), **Storage Sharing**, **Media Server** and **User Accounts**. Click any of them, and you will be able to configure the corresponding functions.

### 5.9.1 Storage Sharing

Choose menu “**USB Settings**→**Storage Sharing**”, you can configure a USB disk drive attached to the router and view volume and share such properties as share name, capacity, used space, and free space on this page as shown below.

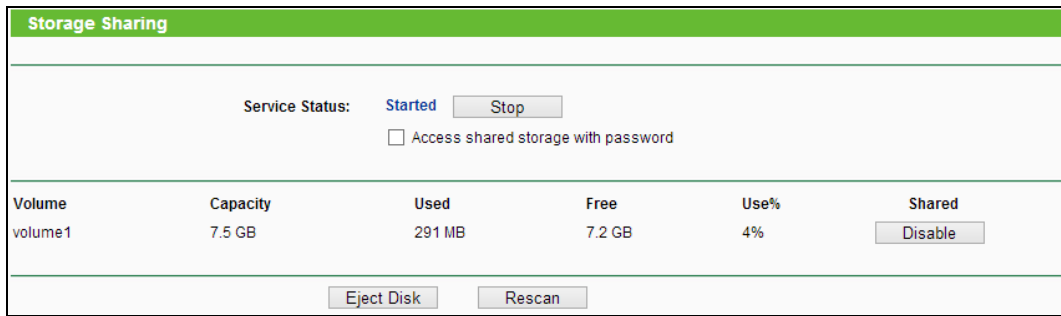

Figure 5-24 Storage Sharing

- **Service Status** - Indicates the Network Sharing service's current status. You can click the **Start** button to start the Storage Sharing service and click the **Stop** button to stop it.
- **Volume** - The volume name of the USB drive the users have access to. Volume 1-8 is mapping to USB port1, and Volume 9-16 is mapping to USB port2.
- **Capacity** - The storage capacity of the USB driver.
- **Used** - The used space of the USB driver.
- **Free** - The available space of the USB driver.
- **Use%** - The percentage of the used space.
- **Shared** - Indicates the shared or non-shared status of the volume. When the volume is shared, you can click the **Disable** to stop sharing the volume; when volume is non-shared, you can click the **Enable** button to share the volume.

Click the **Start** button to start the Network Sharing service.

Click the **Stop** button to stop the Network Sharing service.

Click the **Eject Disk** button to safely remove the USB storage device that is connected to USB port. This takes the drive offline. A message (as shown in Figure 5-25) will appear on your web browser when it is safe to detach the USB disk.

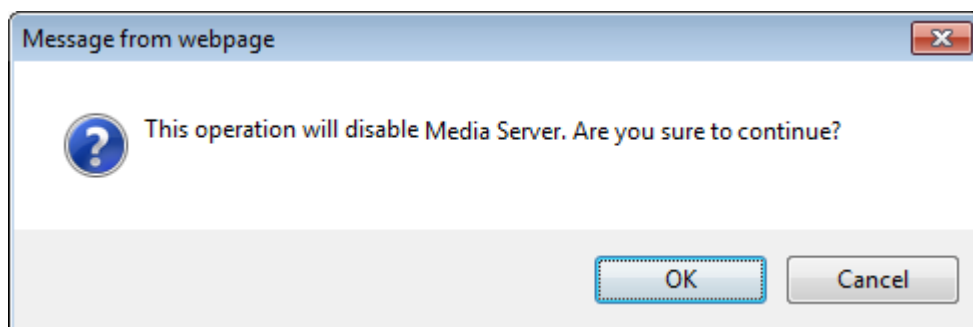

Figure 5-25 Safe Unplug Message

Click the **Rescan** button to start a new scan.

### Follow the instructions below to set up your router as a file server:

1. Plug an external USB hard disk drive or USB flash drive into this router.
2. Click the **Rescan** button to find the USB drive that has been attached to the router.
3. Click the **Start** button to start the Storage Sharing service.
4. Click the **Enable** button under **Shared** to enable the disk to share.
5. Click the **Open the disk** to visit the sharing disk.

#### Note:

1. The router can automatically locate new USB drive. But to display the information about your USB device, you need to click the **Rescan** button manually.
2. The new settings will not take effect until you restart the service.
3. To unplug the USB drive, click **Eject Disk** button first. Simply pulling USB drive out of the USB port can cause damage to the device and loss of data.
4. Mounted volumes of each USB port are subject to the 8-volume limit. So you cannot access more than 8 volumes on the USB storage device.
5. If you change the storage settings during the storage connection is established, then the changes will not take effect until the router or the client is rebooted.

## 5.9.2 FTP Server

Choose menu “**USB Settings**→**FTP Server**”, you can create an FTP server that can be accessed from the Internet or your local network.

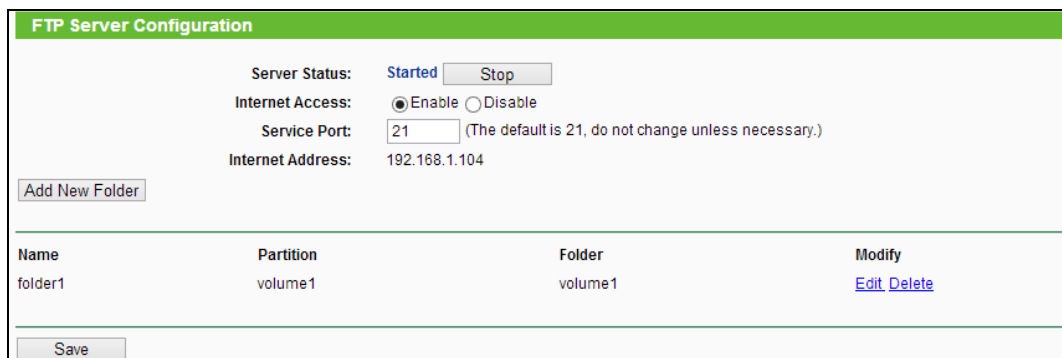

Name	Partition	Folder	Modify
folder1	volume1	volume1	<a href="#">Edit</a> <a href="#">Delete</a>

Figure 5-26 FTP Server Configuration

- **Service Status** - Indicates the FTP Server's current status.
- **Internet Access** - Select enable to allow access of the FTP server from the Internet. Otherwise, select disable to only allow local network access.
- **Service Port** - Enter the FTP Port number to use. The default is 21.
- **Name** - This folder's display name.

- **Partition** - The volume that the folder resides. Volume 1-8 is mapping to USB port1, and Volume 9-16 is mapping to USB port2.
- **Folder** - The real full path of the specified folder.

**To set up your FTP Server, please follow the instructions below:**

1. Plug an external USB hard disk drive or USB flash drive into this Router.
2. Click the **Enable/Disable** radio box to enable/disable Internet access to FTP from Internet port.
3. Specify a port for the FTP server to use (The default port number is 21).
4. The **Internet Address** displays the WAN IP address of this router, so that other users can access FTP via this address.
5. If WAN type is PPPoE/PPTP/L2TP, two connections will be available. Therefore, users can access FTP server via two connections. Users in a private LAN can access ftp server via **Public Address** while Internet users can access ftp server via **Internet Address**.
6. Click the **Start** button to start the ftp server.

**To add a new folder, follow the instructions below.**

1. Click **Add New Folder** in Figure 6-23.

Figure 5-27 Add or Modify Share Folder

2. Select the **Share entire partition** or a specific folder option.
3. Enter display name of the share folder in **Display Name** filed.
4. Click the **Save** button to save the settings.

You can click the **upper** button to go to the upper folder.

You can click the **Back** button to return to the ftp server configuration page.

 **Note:**

The max share folders number is 10. If you want to share a new folder when the number has reached 10, you can delete an existing share folder and then add a new one.

If you want to change the FTP settings, you need to restart FTP Server to make the changes take effect.

### 5.9.3 Media Server

Choose menu “**USB Settings→Media Server**”, you can create media server that allows you to share stored content with other computers and devices on your home network and on the Internet.

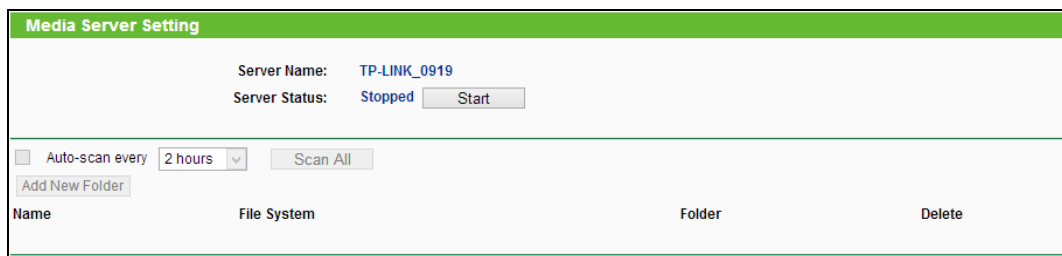

Name	File System	Folder	Delete

Figure 5-28 Media Server Setting

- **Server Name** - The name of this Media Server.
- **Server Status** - Indicates the Media Server’s current status, started or stopped. You can click the **Start** button to start the Media Server and click the **Stop** button to stop it.
- **Name** - The display name of this folder.
- **File System** - The file system type on the partition can be FAT32 or NTFS.
- **Folder** - The real full path of the specified folder.
- **Delete** - You can delete the share folder by click **Delete**.

**To set up your media server, please follow the instructions below:**

1. Plug an external USB hard disk drive or USB flash drive into this router, and then the screen will appear.
2. Click the **Start** button to start the media server.
3. Click the **Add New Folder** button to specify a folder as the search path of media server. The screen will then appear as shown.

Figure 5-29 Add New Folder

- **Display Name** - You can enter a display name for the share folder.
  - **Share entire partition** - Choose this option and then the folders contained in this partition will all be shared.
  - **Folder Location**- Displays the location of this folder.
  - **Select** - Check the radio button to select the folder to share.
  - **Folder** - Displays folders that are in current path.
  - **Upper** - Click this button to get into the upper folder.
  - **Save** - Click this button to save your settings and the page will be redirected to the media server configuration page.
  - **Back** - Click this button to discard the settings and just go to the media server configuration page.
4. Click the **Scan All** button to scan all the share folders immediately. You can also select the **Auto-scan**, at same time, select an auto scan interval time by drop-down list. In this case, the media server will auto scan the share folders.

 **Note:**

The max share folders number is 6. If you want share a new folder when the number has been reached to be 6, you can delete a share folder and then add a new one.

#### 5.9.4 User Accounts

You can specify the user name and password for Storage Sharing users on this page. **Storage Sharing** users can use Internet Explorer to access files on the USB drive.

There are two default user accounts that can access the Storage Sharing. They are Administrator and Guest (as shown in Figure 5-30). Administrator has read/write access to Storage Sharing and



can access FTP Server while Guest has read-only access to Storage Sharing and cannot access FTP Server.

User Account Management				
<a href="#">Add New User</a>				
User Name	Password	Storage Authority	FTP Access	Modify
admin	admin	Read and Write	Read and Write	<a href="#">Edit</a>

Figure 5-30 User Account Management

Only Administrator can use a Web browser to transfer the files from a PC to the Writable shared volume on the USB drive.

**To add a new user account, please follow the steps below:**

1. Click **Add New User** button, and the screen will appear as shown in Figure 5-31.
2. Self-define a **User Name**.
3. Enter the password in the **Password** field.
4. Choose the Storage Authority from the drop-down list, **Read and Write** or **Read Only**.

Add or Modify User Account	
User Name:	<input type="text" value="admin1"/>
Password:	<input type="text" value="admin"/>
Storage Authority:	<input type="text" value="Read Only"/> ▼
FTP Access:	<input type="text" value="No"/> ▼
<input type="button" value="Save"/> <input type="button" value="Back"/>	

Figure 5-31 Add or Modify User Account

- **User Name** - Type the user name that you want to give access to the USB drive. The user name must be composed of alphanumeric symbols not exceeding 15 characters in length.
- **Password** - Enter the password in the Password field. The password must be composed of alphanumeric symbols not exceeding 15 characters in length. For security purposes, the password for each user account is not displayed.
- **Storage Authority** - Choose **Read and Write** or **Read Only** from the drop-down list to assign access authority of Storage Sharing to the user.
- **Save** - You can click the **Save** button to save your settings.
- **Back** - You can click the **Back** button to discard the settings and just go to the media server configuration page.

**Note:**

Please restart the service for the new settings to take effect.

If you cannot use the new user name and password to access the shares, press **Windows logo + R** to open the Run dialog box and type **net use \\192.168.0.254 /delete /yes** and press Enter. (192.168.0.254 is your router's LAN IP address. If the LAN IP of the modem connected with your router is 192.168.1.x, the default LAN IP of the router will automatically switch from 192.168.0.254 to 192.168.1.254 to avoid IP conflict; in this case, please try **net use \\192.168.1.254 /delete / yes.**)

## 5.10 System Tools



Figure 5-32 The System Tools menu

Choose menu "**System Tools**", and then you can see the submenus under the main menu: **Diagnostic**, **Ping Watch Dog**, **Factory Defaults**, **Backup & Restore**, **Reboot**, **Password**, and **System Log**. Click any of them, and you will be able to configure the corresponding function. The detailed explanations for each submenu are provided below.

### 5.10.1 Diagnostic

Choose menu "**System Tools** → **Diagnostic**", and then you can transact Ping or Traceroute function to check connectivity of your network in the following screen.

**Diagnostic Tools**

**Diagnostic Parameters**

Diagnostic Tool:  Ping  Traceroute

IP Address/ Domain Name:

Ping Count:  (1-50)

Ping Packet Size:  (4-1472 Bytes)

Ping Timeout:  (100-2000 Milliseconds)

Traceroute Max TTL:  (1-30)

**Diagnostic Results**

This device is ready.

Start

Figure 5-33 Diagnostic Tools

- **Diagnostic Tool** - Check the radio button to select one diagnostic tool.
  - **Ping** - This diagnostic tool troubleshoots connectivity, reachability, and name resolution to a given host or gateway.
  - **Traceroute** - This diagnostic tool tests the performance of a connection.

**Note:**

You can use ping/traceroute to test both numeric IP address or domain name. If pinging/tracerouting the IP address is successful, but pinging/tracerouting the domain name is not, you might have a name resolution problem. In this case, ensure that the domain name you are specifying can be resolved by using Domain Name System (DNS) queries.

- **IP Address/Domain Name** - Type the destination IP address (e.g. 202.108.22.5) or Domain name (e.g. http://www.tp-link.com).
- **Pings Count** - The number of Ping packets for a Ping connection. The default is 4.
- **Ping Packet Size** - The size of Ping packet. The default is 64.
- **Ping Timeout** - Set the waiting time for the reply of each Ping packet. If there is no reply in the specified time, the connection is overtime. The default is 800.
- **Traceroute Max TTL** - The max number of hops for a Traceroute connection. The default is 20.

Click **Start** to check the connectivity of the Internet.

The **Diagnostic Results** page displays the result of diagnosis.

If the result is similar to the following screen, the connectivity of the Internet is fine.

```

Diagnostic Results

Pinging 202.108.22.5 with 64 bytes of data:

Reply from 202.108.22.5: bytes=64 time=1 TTL=127 seq=1
Reply from 202.108.22.5: bytes=64 time=1 TTL=127 seq=2
Reply from 202.108.22.5: bytes=64 time=1 TTL=127 seq=3
Reply from 202.108.22.5: bytes=64 time=1 TTL=127 seq=4

Ping statistics for 202.108.22.5
Packets: Sent = 4, Received = 4, Lost = 0 (0% loss),
Approximate round trip times in milliseconds:
Minimum = 1, Maximum = 1, Average = 1

```

Figure 5-34 Diagnostic Results

**Note:**

Only one user can use this tool at one time. Options “Number of Pings”, “Ping Size” and “Ping Timeout” are used for **Ping** function. Option “Tracert Hops” are used for **Tracert** function.

**5.10.2 Ping Watch Dog**

Choose menu “**System Tools** → **Ping Watch Dog**”, and then you can see the following screen.

Ping Watch Dog Utility	
Enable:	<input checked="" type="checkbox"/>
IP Address:	<input type="text"/>
Interval:	<input type="text" value="300"/> (10-300) seconds
Delay:	<input type="text" value="300"/> (60-300) seconds
Fail Count:	<input type="text" value="3"/> (1-65535)
<input type="button" value="Save"/>	

Figure 5-35 Ping Watch Dog Utility

The **Ping Watch Dog** is dedicated for continuous monitoring of the particular connection to remote host using the Ping tool. It makes this device continuously ping a user defined IP address (it can be the internet gateway for example). If it is unable to ping under the user defined constraints, this device will automatically reboot.

- **Enable** - Turn on/off Ping Watch Dog.
- **IP Address** - The IP address of the target host where the Ping Watch Dog Utility is sending ping packets.
- **Interval** - Time interval between two ping packets which are sent out continuously.
- **Delay** - Time delay before first ping packet is sent out when this device is restarted.
- **Fail Count** - Upper limit of the ping packet this device can drop continuously. If this value is overrun, this device will restart automatically.

Be sure to click the **Save** button to make your settings in operation.

### 5.10.3 Firmware Upgrade

Choose menu “**System Tools** → **Firmware Upgrade**”, and then you can update the latest version of firmware for the Router on the following screen.

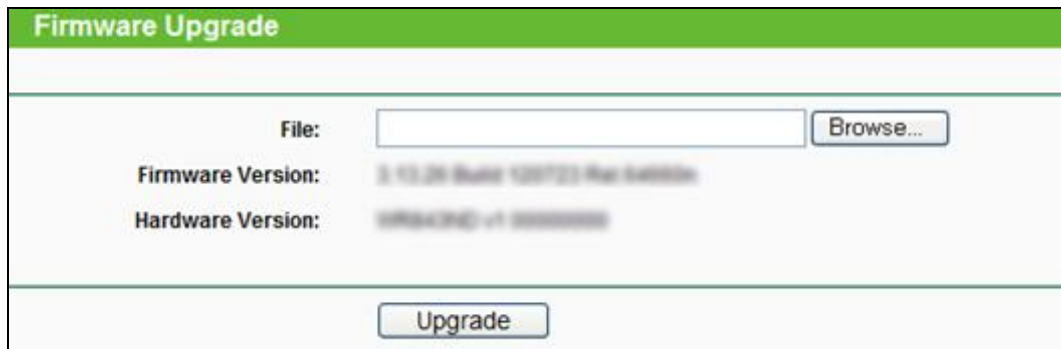

Figure 5-36 Firmware Upgrade

- **Firmware Version** - This displays the current firmware version.
- **Hardware Version** - This displays the current hardware version. The hardware version of the upgrade file must accord with the Router’s current hardware version.

**To upgrade the Router's firmware, follow these instructions below:**

1. Download a more recent firmware upgrade file from the TP-LINK website <http://www.tp-link.com>.
2. Type the path and file name of the update file into the **File** field, or click the **Browse** button to locate the update file.
3. Click the **Upgrade** button.

**Note:**

1. New firmware versions are posted at <http://www.tp-link.com> and can be downloaded for free. There is no need to upgrade the firmware unless the new firmware has a new feature you want to use. However, when experiencing problems caused by the Router rather than the configuration, you can try to upgrade the firmware.
2. When you upgrade the Router's firmware, you may lose its current configurations, so before upgrading the firmware please write down some of your customized settings to avoid losing important settings.
3. Do not turn off the Router or press the Reset button while the firmware is being upgraded, otherwise, the Router may be damaged.
4. The Router will reboot after the upgrading has been finished.

### 5.10.4 Factory Defaults

Choose menu “**System Tools** → **Factory Defaults**”, and you can restore the configurations of the Router to factory defaults on the following screen.

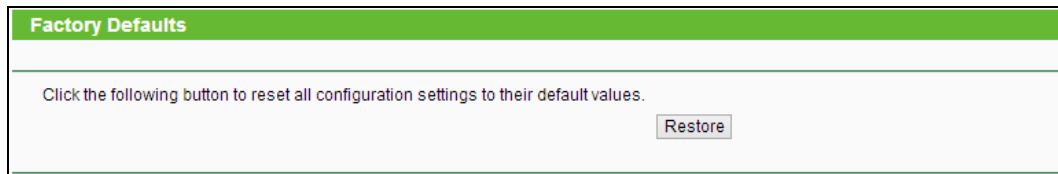

Figure 5-37 Restore Factory Default

Click the **Restore** button to reset all configuration settings to their default values.

- The default **User Name**: admin
- The default **Password**: admin
- The default **IP Address**: 192.168.0.254
- The default **Subnet Mask**: 255.255.255.0

**Note:**

All changed settings will be lost when defaults are restored.

### 5.10.5 Backup & Restore

Choose menu “**System Tools** → **Backup & Restore**”, and then you can save the current configuration of the Router as a backup file and restore the configuration via a backup file as shown in Figure 5-38.

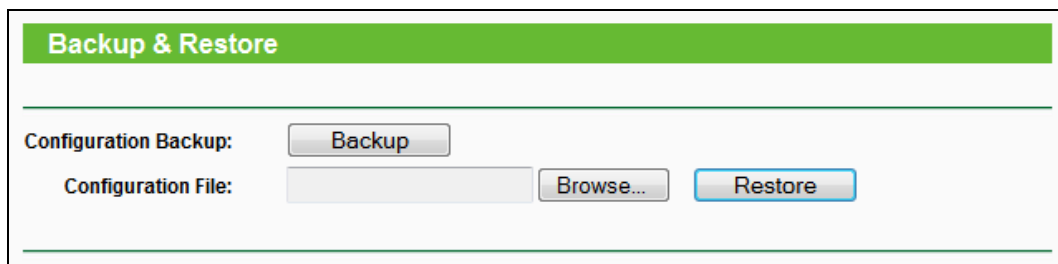

Figure 5-38 Backup &amp; Restore Configuration

- Click the **Backup** button to save all configuration settings as a backup file in your local computer.
- To upgrade the Router's configuration, follow these instructions.
  - Click the **Browse...** button to locate the update file for the Router, or enter the exact path to the Setting file in the text box.
  - Click the **Restore** button.

**Note:**

The current configuration will be covered by the uploading configuration file. The upgrade process lasts for 20 seconds and the Router will restart automatically. Keep the Router on during the upgrading process to prevent any damage.

### 5.10.6 Reboot

Choose menu “**System Tools** → **Reboot**”, and then you can click the **Reboot** button to reboot the Router via the next screen.

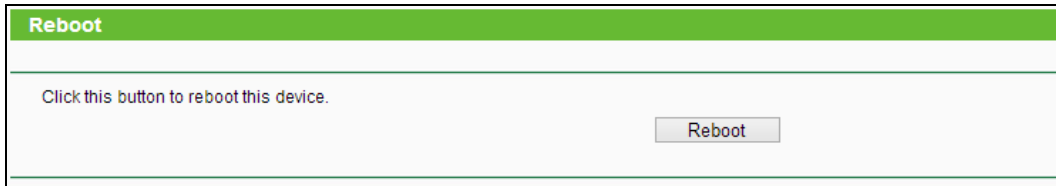

Figure 5-39 Reboot the Router

Some settings of the Router will take effect only after rebooting, which include:

- Change the LAN IP Address (system will reboot automatically).
- Change the DHCP Settings.
- Change the Wireless configurations.
- Change the Web Management Port.
- Upgrade the firmware of the Router (system will reboot automatically).
- Restore the Router's settings to factory defaults (system will reboot automatically).
- Update the configuration with the file (system will reboot automatically).

### 5.10.7 Password

Choose menu “**System Tools** → **Password**”, and then you can change the factory default user name and password of the Router in the next screen as shown in Figure 5-40.

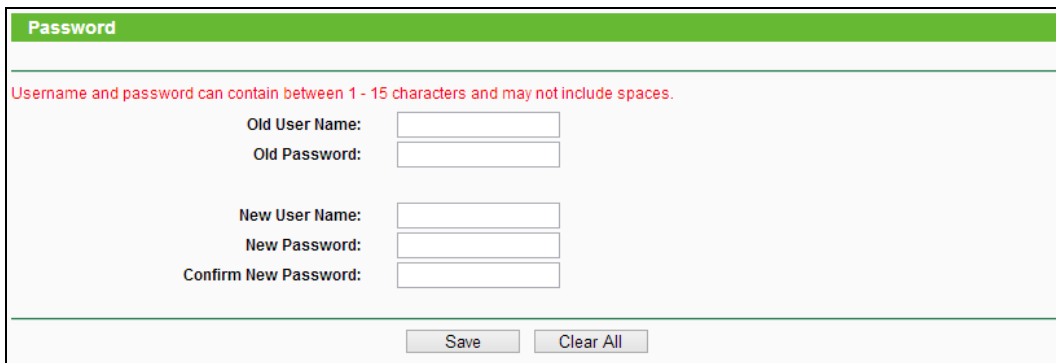

Figure 5-40 Password

It is strongly recommended that you should change the factory default user name and password of the Router, because all users who try to access the Router's Web-based utility or Quick Setup will be prompted for the Router's default user name and password.

 **Note:**

The new user name and password must not exceed 14 characters in length and not include any spaces. Enter the new Password twice to confirm.

Click the **Save** button when finished.

Click the **Clear All** button to clear all.

### 5.10.8 System Log

Choose menu “**System Tools** → **System Log**”, and then you can view the logs of the Router.

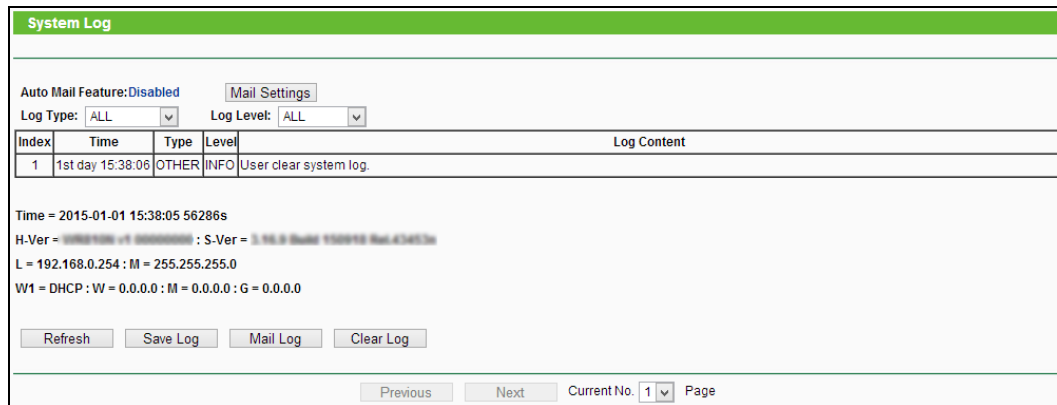

The screenshot shows the 'System Log' page. At the top, there is a green header with the text 'System Log'. Below the header, there is a section for 'Auto Mail Feature: Disabled' with a 'Mail Settings' button. Underneath, there are two dropdown menus: 'Log Type: ALL' and 'Log Level: ALL'. A table with the following content is displayed:

Index	Time	Type	Level	Log Content
1	1st day 15:38:06	OTHER	INFO	User clear system log.

Below the table, there is a block of system information: 'Time = 2015-01-01 15:38:05 56286s', 'H-Ver = ... : S-Ver = ...', 'L = 192.168.0.254 : M = 255.255.255.0', and 'W1 = DHCP : W = 0.0.0.0 : M = 0.0.0.0 : G = 0.0.0.0'. At the bottom of the log area, there are four buttons: 'Refresh', 'Save Log', 'Mail Log', and 'Clear Log'. At the very bottom of the page, there are navigation buttons: 'Previous', 'Next', 'Current No. 1', and 'Page'.

Figure 5-41 System Log

- **Refresh** - Refresh the page to show the latest log list.
- **Save Log** - Click to save all the logs in a txt file.
- **Mail Log** - Click to send an email of current logs manually according to the address and validation information set in Mail Settings. The result will be shown in the later log soon.
- **Clear Log** - All the logs will be deleted from this device permanently, not just from the page.



## Chapter 6. Configuration for Repeater Mode

This chapter will show each Web page's key functions and the configuration way for Repeater Mode of TL-WR810N.

### 6.1 Login

After your successful login, you can configure and manage the device. There are main menus on the left of the web-based utility. Submenus will be available after you click one of the main menus. On the right, there are the corresponding explanations and instructions.

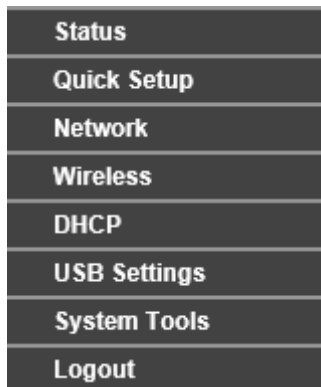

Status
Quick Setup
Network
Wireless
DHCP
USB Settings
System Tools
Logout

Figure 6-1

The detailed explanations for each Web page's key function are listed below.

### 6.2 Status

The Status page provides the current status information about the Router on Repeater Mode. All information is read-only.

Status		
Firmware Version:	3.10.3 Build 150919 Rel.42473n	
Hardware Version:	V04R10N v1 00000000	
<b>Wired</b>		
MAC Address:	00-0A-EB-13-09-19	
IP Address:	192.168.0.254	
Subnet Mask:	255.255.255.0	
<b>Wireless</b>		
Working Mode:	Repeater	
Wireless Name of Root AP:	TP-LINK_E837	
Channel:	6	
Mode:	11bgn mixed	
Channel Width:	Automatic	
Max Tx Rate:	300Mbps	
MAC Address:	00-0A-EB-13-09-19	
<b>Traffic Statistics</b>		
	Received	Sent
Bytes:	10,047	686
Packets:	89	2
System Up Time:	0 days 00:04:48	
		<input type="button" value="Refresh"/>

Figure 6-2 Status

- **Firmware Version** - The version information of the Router's firmware.
- **Hardware Version** - The version information of the Router's hardware.
- **Wired** - This field displays the current settings or information for the LAN, you can configure them in the **Network > LAN** page.
  - **MAC address** - The physical address of the Router, as seen from the LAN.
  - **IP address** - The LAN IP address of the Router.
  - **Subnet Mask** - The subnet mask associated with LAN IP address.
- **Wireless** - This field displays basic information or status for wireless function, you can configure them in the **Wireless > Wireless Settings** page.
  - **Working Mode** - The current wireless working mode in use.
  - **Wireless Name of Root AP** - The SSID of Root AP.
  - **Channel** - The current wireless channel in use.
  - **Mode** - The current wireless mode which the Router works on.
  - **Channel Width** - The current wireless channel width in use.
  - **MAC Address** - The physical address of the Router, as seen from the WLAN.
- **Traffic Statistics** - The Router's traffic statistics.

- **Received (Bytes)** - Traffic that counted in bytes has been received out from the WAN port.
  - **Received (Packets)** - Traffic that counted in packets has been received out from the WAN port.
  - **Sent (Bytes)** - Traffic that counted in bytes has been sent out from the WAN port.
  - **Sent (Packets)** - Traffic that counted in packets has been sent out from the WAN port.
- **System Up Time** - The length of the time since the Router was last powered on or reset.

Click the **Refresh** button to get the latest status and settings of the Router.

## 6.3 Quick Setup

Please refer to [Section 3.2: Quick Installation Guide](#).

## 6.4 Network



Figure 6-3 The Network menu

There is only one submenu under the Network menu (shown in Figure 6-3): **LAN**.

### 6.4.1 LAN

Choose menu "**Network** → **LAN**", and then you can configure the IP parameters of the LAN on the screen as below.

 A screenshot of the LAN configuration page. At the top is a green header with the text 'LAN'. Below it, the following fields are visible:
 

- MAC Address:** 00-0A-EB-13-09-19
- Type:** Smart IP(DHCP) (dropdown menu)
- IP Address:** 192.168.0.254
- Subnet Mask:** 255.255.255.0 (dropdown menu)
- Gateway:** 0.0.0.0
- Allow remote access

 A note at the bottom reads: "Note: The IP parameters cannot be configured if you have chosen Smart IP (DHCP) (In this situation the device will help you configure the IP parameters automatically as you need)." A 'Save' button is located at the bottom center.

Figure 6-4 LAN

- **MAC Address** - The physical address of the LAN ports, as seen from the LAN. The value can not be changed.
- **Type** - Choosing Smart IP(DHCP) to get IP address from DHCP server, or choosing static IP to config IP address manually.
- **IP Address** - Enter the IP address of your system in dotted-decimal notation (factory default - 192.168.0.254).

- **Subnet Mask** - An address code that determines the size of the network. Normally 255.255.255.0 is used as the subnet mask.
- **Gateway** - The gateway should be in the same subnet as your IP address.
- **Allow remote access** - Allow remote devices to access the AP device by inputting the IP address in browser.

 **Note:**

1. If you change the IP address, you must use the new IP address to login the system.
2. If you select the type of Smart IP (DHCP), the DHCP server in this device will not startup.
3. If the new IP address you set is not in the same subnet, the IP Address pool in the DHCP server will not take effect, until they are re-configured.
4. This device will reboot automatically after you click the **Save** button.

Click the **Save** button to save your settings.

 **Note:**

When you choose the Smart IP (DHCP) mode, the DHCP Server function will be disabled.

## 6.5 Wireless



Figure 6-5 Wireless menu

There are six submenus under the Wireless menu (shown in Figure 6-5): **Wireless Settings**, **Wireless Security**, **MAC Filtering**, **Wireless Advanced**, **Wireless Statistics** and **Throughput Monitor**. Click it, and you will be able to configure the corresponding function.

### 6.5.1 Wireless Settings

Choose menu “**Wireless** → **Wireless Settings**”, and then you can configure the basic settings for the wireless network on this page.

Figure 6-6 Wireless Settings - Repeater

- **Wireless Name of Root AP** - The SSID of AP that you want to access.
- **MAC Address of Root AP** - The MAC address of AP that you want to access.
- **Region** - Select your region from the pull-down list. This field specifies the region where the wireless function of the Router can be used. It may be illegal to use the wireless function of the Router in a region other than one of those specified in this field. If your country or region is not listed, please contact your local government agency for assistance.
- **Mode** - Select the desired mode. The default setting is 11bgn mixed.
  - **11bg mixed** - Select if you are using both 802.11b and 802.11g wireless clients.
  - **11bgn mixed** - Select if you are using a mix of 802.11b, 11g, and 11n wireless clients.

When 11bg mixed mode is selected, only 11bg mixed wireless stations can connect to the Router. It is strongly recommended that you set the Mode to 11bgn mixed, and all of 802.11b/g/n wireless stations can connect to the Router.

**Note:**

If **11bg mixed mode** is selected in the **Mode** field, the **Channel Width** selecting field will turn grey and the value will become 20M, which is unable to be changed.
- **Channel Width** - Select any channel width from the pull-down list. The default setting is automatic, which can automatically adjust the channel width for your clients.
- **WDS Mode** - This field determines which WDS Mode will be used. It is not necessary to change the WDS Mode unless you notice network communication problems with root AP. If you select Auto, then Router will choose the appropriate WDS Mode automatically.

- **Enable Wireless Radio** - The wireless radio of the Router can be enabled or disabled to allow wireless stations access. If enabled, the wireless stations will be able to access the Router. Otherwise, wireless stations will not be able to access the Router.
- **Survey** - Click this button, you can search the AP which runs in the environment.

Click **Survey** button on the Wireless page as shown in Figure 6-6, and then AP List page will appear as shown in Figure 6-7. Find the SSID of the Access Point you want to access, and click **Connect** in the corresponding row. For example, the third item is selected. The target network's SSID will be automatically filled into the corresponding box which is shown as the Figure 6-6.

AP List						
AP Count: 16						
ID	BSSID	SSID	Signal	Channel	Security	Choose
1	6C-E8-73-CA-EE-68		68dB	4	None	<a href="#">Connect</a>
2	94-0C-6D-2F-3C-BE	TP-LINK_Network	47dB	4	WPA2-PSK	<a href="#">Connect</a>
3	84-1B-5E-D7-64-F2	TP-LINK_4234CC	31dB	1	WPA2-PSK	<a href="#">Connect</a>
4	4C-60-DE-32-63-8C	TP-LINK_18F710	30dB	11	WPA2-PSK	<a href="#">Connect</a>
5	6C-E8-73-CA-EE-6A	TP-LINK_D0A761	27dB	4	None	<a href="#">Connect</a>
6	14-E6-E4-E3-87-6A	TP-LINK_TEST	16dB	6	WPA2-PSK	<a href="#">Connect</a>

Back Refresh

Figure 6-7 AP List

Be sure to click the **Save** button to save your settings on this page.

**Note:**

1. The operating distance or range of your wireless connection varies significantly based on the physical placement of the Router. For best results, place your Router.
  - Near the center of the area in which your wireless stations will operate.
  - In an elevated location such as a high shelf.
  - Away from the potential sources of interference, such as PCs, microwaves, and cordless phones.
  - Away from large metal surfaces.
2. Failure to follow these guidelines can result in significant performance degradation or inability to wirelessly connect to the Router.

## 6.5.2 Wireless Security

Choose menu **“Wireless → Wireless Security”**, and then you can configure the security settings of your wireless network.

There are three wireless security modes supported by the Router: WPA/WPA2-Personal, WPA/WPA2-Enterprise and WEP (Wired Equivalent Privacy).

Figure 6-8 Wireless Security

- **Disable Security** - The wireless security function can be enabled or disabled. If disabled, the wireless stations will be able to connect the Router without encryption. But it's strongly recommended to choose one of the following modes to enable security.
- **WPA-PSK/WPA2-Personal** - It's the WPA/WPA2 authentication type based on pre-shared passphrase.
  - **Version** - you can choose the version of the WPA-PSK security on the drop-down list. The default setting is **Automatic**, which can select **WPA-PSK** (Pre-shared key of WPA) or **WPA2-PSK** (Pre-shared key of WPA) automatically based on the wireless station's capability and request.
  - **Encryption** - When **WPA-PSK** or **WPA** is set as the Authentication Type, you can select either **Automatic**, or **TKIP** or **AES** as Encryption.
  - **Wireless Password** - You can enter ASCII or Hexadecimal characters. For Hexadecimal, the length should be between 8 and 64 characters; for ASCII, the length should be between 8 and 63 characters.
  - **Group Key Update Period** - Specify the group key update interval in seconds. The value can be either 0 or at least 30. Enter 0 to disable the update.

 **Note:**

If you check the **WPA/WPA2-Personal** radio button and choose TKIP encryption, you will find a notice in red.

<input checked="" type="radio"/> WPA/WPA2 - Personal(Recommended)	
Version:	Automatic
Encryption:	TKIP
Wireless Password:	12345670
<small>(You can enter ASCII characters between 8 and 63 or Hexadecimal characters between 8 and 64.)</small>	
Group Key Update Period:	0 Seconds
<small>(Keep it default if you are not sure, minimum is 30, 0 means no update)</small>	
<small>We do not recommend using the TKIP encryption if this device operates in 802.11n mode due to the fact that TKIP is not supported by 802.11n specification.</small>	

➤ **WPA /WPA2-Enterprise** - It's based on Radius Server.

- **Version** - you can choose the version of the WPA security from the pull-down list. The default setting is **Automatic**, which can select **WPA** (Wi-Fi Protected Access) or **WPA2** (WPA version 2) automatically based on the wireless station's capability and request.
- **Encryption** - You can select **Automatic**, **TKIP** or **AES**.
- **Radius Server IP** - Enter the IP address of the Radius server.
- **Radius Port** - Enter the port that Radius server used.
- **Radius Password** - Enter the password for the Radius server.
- **Group Key Update Period** - Specify the group key update interval in seconds. The value should be 30 or above. Enter 0 to disable the update.

➤ **WEP** - It is based on the IEEE 802.11 standard.

- **Type** - you can choose the type for the WEP security on the pull-down list. The default setting is **Automatic**, which can select **Shared Key** or **Open System** authentication type automatically based on the wireless station's capability and request.
- **WEP Key Format** - **Hexadecimal** and **ASCII** formats are provided here. **Hexadecimal** format stands for any combination of hexadecimal digits (0-9, a-f, A-F) in the specified length. **ASCII** format stands for any combination of keyboard characters in the specified length.
- **WEP Key (Password)** - Select which of the four keys will be used and enter the matching WEP key that you create. Make sure these values are identical on all wireless stations in your network.
- **Key Type** - You can select the WEP key length (64-bit, or 128-bit, or 152-bit.) for encryption. "Disabled" means this WEP key entry is invalid.
  - 64-bit** - You can enter 10 hexadecimal digits (any combination of 0-9, a-f, A-F, and null key is not permitted) or 5 ASCII characters.
  - 128-bit** - You can enter 26 hexadecimal digits (any combination of 0-9, a-f, A-F, and null key is not permitted) or 13 ASCII characters.
  - 152-bit** - You can enter 32 hexadecimal digits (any combination of 0-9, a-f, A-F, and null key is not permitted) or 16 ASCII characters.



 **Note:**

If you do not set the key, the wireless security function is still disabled even if you have selected Shared Key as Authentication Type.

### 6.5.3 Wireless MAC Filtering

Choose menu **“Wireless → Wireless MAC Filtering”**, and then you can control the wireless access by configuring the **Wireless MAC Filtering** function, as shown in Figure 6-9.

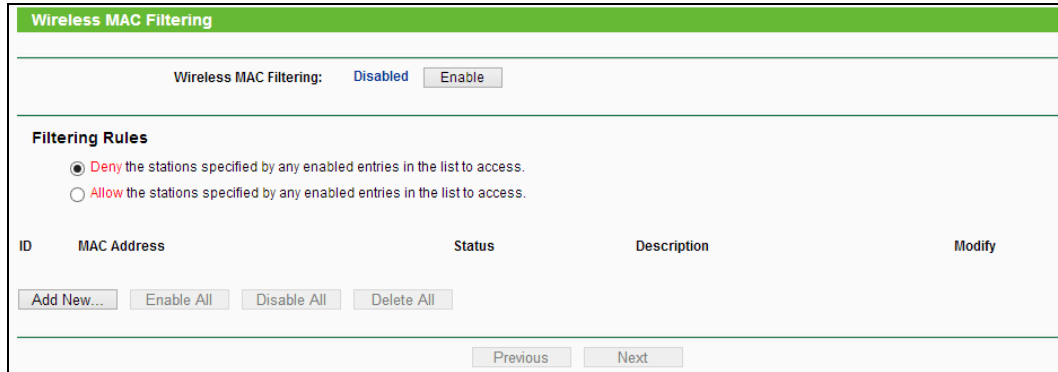

Figure 6-9 Wireless MAC Filtering

To filter wireless users by MAC Address, click **Enable**. The default setting is **Disabled**.

- **MAC Address** - The wireless station's MAC address that you want to access.
- **Status** - The status of this entry, either **Enabled** or **Disabled**.
- **Description** - A simple description of the wireless station.

To Add a Wireless MAC Address filtering entry, click the **Add New...** button. The **"Add or Modify Wireless MAC Address Filtering entry"** page will appear, shown in Figure 6-10:

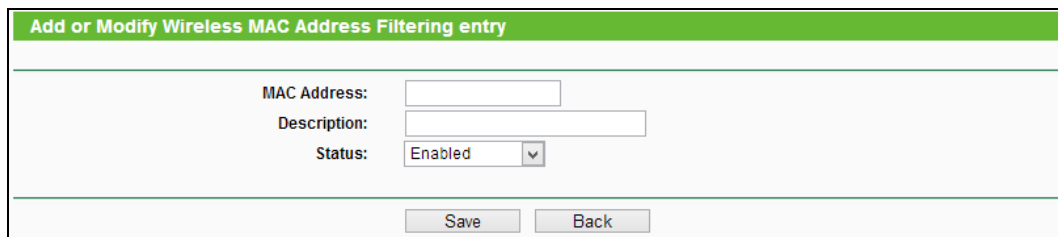

Figure 6-10 Add or Modify Wireless MAC Address Filtering entry

**To add or modify a MAC Address Filtering entry, follow these instructions:**

1. Enter the appropriate MAC Address into the **MAC Address** field. The format of the MAC Address is XX-XX-XX-XX-XX-XX (X is any hexadecimal digit). For example: 00-0A-EB-B0-00-0B.
2. Give a simple description for the wireless station in the **Description** field. For example: Wireless station A.
3. Select **Enabled** or **Disabled** for this entry on the **Status** pull-down list.

4. Click the **Save** button to save this entry.

**To modify an existing entry:**

1. Click the **Modify** in the entry you want to modify.
2. Modify the information.
3. Click the **Save** button.

Click the **Delete** in the entry you want to delete to delete an existing entry.

Click the **Enable All** button to make all entries enabled

Click the **Disable All** button to make all entries disabled.

Click the **Delete All** button to delete all entries.

Click the **Next** button to go to the next page.

Click the **Previous** button to return to the previous page.

**For example:** If you desire that the wireless station A with MAC address 00-0A-EB-B0-00-0B and the wireless station B with MAC address 00-0A-EB-00-07-5F are able to access the Router, but all the other wireless stations cannot access the Router, you can configure the **Wireless MAC Address Filtering** list by following these steps:

1. Click the **Enable** button to enable this function.
2. Select the radio button “Allow the stations specified by any enabled entries in the list to access” for **Filtering Rules**.
3. Delete all or disable all entries if there are any entries already.
4. Click the **Add New...** button.
  - Enter the MAC address 00-0A-EB-B0-00-0B/00-0A-EB-00-07-5F in the **MAC Address** field.
  - Enter wireless station A/B in the **Description** field.
  - Select **Enabled** in the **Status** pull-down list.
  - Click the **Save** button.
  - Click the **Back** button.

The filtering rules that configured should be similar to the following list:

Filtering Rules				
<input type="radio"/> Deny the stations specified by any enabled entries in the list to access.				
<input checked="" type="radio"/> Allow the stations specified by any enabled entries in the list to access.				
ID	MAC Address	Status	Description	Modify
1	00-0A-EB-B0-00-0B	Enabled	wireless station A	<a href="#">Modify</a> <a href="#">Delete</a>
2	00-0A-EB-00-07-5F	Enabled	wireless station B	<a href="#">Modify</a> <a href="#">Delete</a>

## 6.5.4 Wireless Advanced

Choose menu “**Wireless** → **Wireless Advanced**”, and then you can configure the advanced settings of your wireless network.

Figure 6-11 Wireless Advanced

- **Transmit Power** - Here you can specify the transmit power of Router. You can select High, Middle or Low which you would like. High is the default setting and is recommended.
- **Beacon Interval** - Enter a value between 20-1000 milliseconds for Beacon Interval here. The beacons are the packets sent by the Router to synchronize a wireless network. Beacon Interval value determines the time interval of the beacons. The default value is 100.
- **RTS Threshold** - Here you can specify the RTS (Request to Send) Threshold. If the packet is larger than the specified RTS Threshold size, the Router will send RTS frames to a particular receiving station and negotiate the sending of a data frame. The default value is 2346.
- **Fragmentation Threshold** - This value is the maximum size determining whether packets will be fragmented. Setting the Fragmentation Threshold too low may result in poor network performance because of excessive packets. 2346 is the default setting and is recommended.
- **DTIM Interval** - This value determines the interval of the Delivery Traffic Indication Message (DTIM). A DTIM field is a countdown field informing clients of the next window for listening to broadcast and multicast messages. When the Router has buffered broadcast or multicast messages for associated clients, it sends the next DTIM with a DTIM Interval value. You can specify the value between 1-255 Beacon Intervals. The default value is 1, which indicates the DTIM Interval is the same as Beacon Interval.
- **Enable WMM** - **WMM** function can guarantee the packets with high-priority messages being transmitted preferentially. It is strongly recommended enabled.
- **Enable Short GI** - This function is recommended for it will increase the data capacity by reducing the guard interval time.

- **Enable AP Isolation** - This function isolate all connected wireless stations so that wireless stations cannot access each other through WLAN. This function will be disabled if WDS/Bridge is enabled.

**Note:**

If you are not familiar with the setting items in this page, it's strongly recommended to keep the provided default values; otherwise it may result in lower wireless network performance.

### 6.5.5 Wireless Statistics

Choose menu "**Wireless** → **Wireless Statistics**", and then you can see the MAC Address, Current Status, Received Packets and Sent Packets for each connected wireless station.

Wireless Statistics						
Current Connected Wireless Stations numbers:					1	<input type="button" value="Refresh"/>
ID	MAC Address	Current Status	Received Packets	Sent Packets	Configure	
1	70-73-CB-1F-C8-C9	STA-ASSOC	46	16	<input type="button" value="Allow"/>	

Figure 6-12 Wireless Statistics

- **MAC Address** - The connected wireless station's MAC address
- **Current Status** - The connected wireless station's running status, one of **STA-AUTH** / **STA-ASSOC** / **STA-JOINED** / **WPA** / **WPA-PSK** / **WPA2** / **WPA2-PSK** / **AP-UP** / **AP-DOWN** / **Disconnected**
- **Received Packets** - Packets received by the station
- **Sent Packets** - Packets sent by the station
- **Configure** - The button is used for loading the item to the **Wireless MAC Filtering** list.
  - **Allow** - If the **Wireless MAC Filtering** function enable, allow the station to access.
  - **Deny** - If the **Wireless MAC Filtering** function enable, deny the station to access.

You cannot change any of the values on this page. To update this page and to show the current connected wireless stations, click on the **Refresh** button.

If the numbers of connected wireless stations go beyond one page, click the **Next** button to go to the next page and click the **Previous** button to return the previous page.

**Note:**

This page will be refreshed automatically every 5 seconds.

## 6.5.6 Throughput Monitor

Choose menu “**Wireless** → **Throughput Monitor**”, and then you can see the wireless throughput info.

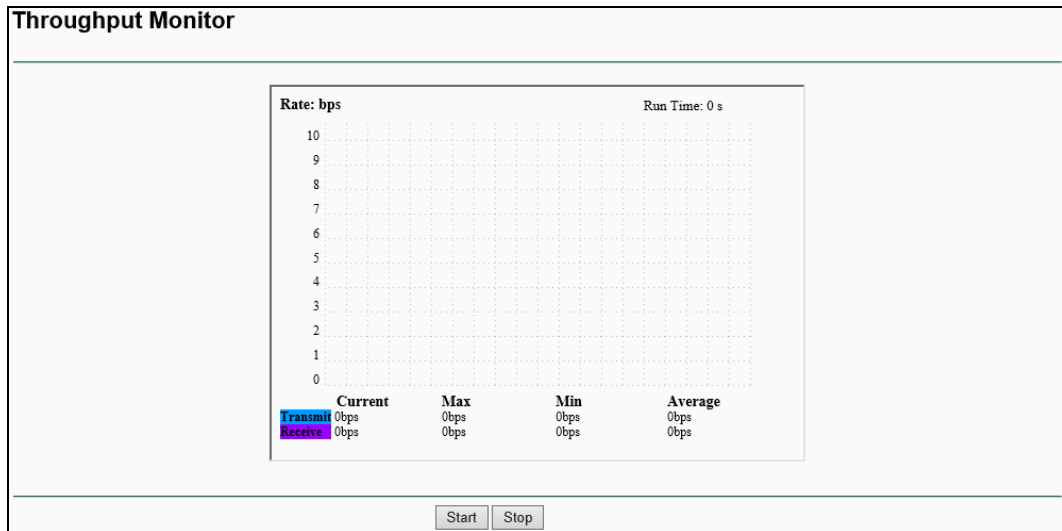

Figure 6-13 Wireless Statistics

- **Rate** - The Throughput unit.
- **Run Time** - How long this function is running.
- **Transmit** - Wireless transmit rate information.
- **Receive** - Wireless receive rate information.

Click the **Start** button to start wireless throughput monitor.

Click the **Stop** button to stop wireless throughput monitor.

## 6.6 DHCP

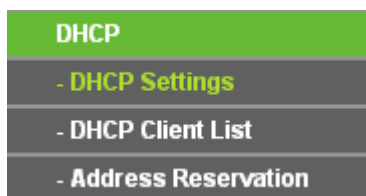

Figure 6-14 The DHCP menu

There are three submenus under the DHCP menu (shown in Figure 6-14), **DHCP Settings**, **DHCP Client List** and **Address Reservation**. Click any of them, and you will be able to configure the corresponding function.

### 6.6.1 DHCP Settings

Choose menu “**DHCP** → **DHCP Settings**”, and then you can configure the DHCP Server on the page as shown in Figure 6-15. The Router is set up by default as a DHCP (Dynamic Host

Configuration Protocol) server, which provides the TCP/IP configuration for all the PC(s) that are connected to the Router in the LAN.

Figure 6-15 DHCP Settings

- **DHCP Server - Enable or Disable** the DHCP server. If you disable the Server, you must have another DHCP server within your network or else you must configure the computer manually.
- **Start IP Address** - Specify an IP address for the DHCP Server to start with when assigning IP addresses. 192.168.0.100 is the default start address.
- **End IP Address** - Specify an IP address for the DHCP Server to end with when assigning IP addresses. 192.168.0.199 is the default end address.
- **Address Lease Time** - The **Address Lease Time** is the amount of time a network user will be allowed connection to the Router with their current dynamic IP Address. Enter the amount of time in minutes and the user will be "leased" this dynamic IP Address. After the time is up, the user will be automatically assigned a new dynamic IP address. The range of the time is 1 ~ 2880 minutes. The default value is 120 minutes.
- **Default Gateway** (Optional) - It is suggested to input the IP address of the LAN port of the Router. The default value is 192.168.0.254.
- **Default Domain** (Optional) - Input the domain name of your network.
- **Primary DNS** - (Optional) Input the DNS IP address provided by your ISP or consult your ISP.
- **Secondary DNS** (Optional) - Input the IP address of another DNS server if your ISP provides two DNS servers.

 **Note:**

1. To use the DHCP server function of the Router, you must configure all computers on the LAN as "Obtain an IP Address automatically".
2. When you choose the Smart IP (DHCP) mode in Network → LAN, the DHCP Server function will be disabled. You will see the page as below.

**DHCP Settings**

DHCP Server:  Disable  Enable

Start IP Address:

End IP Address:

Address Lease Time:  minutes (1~2880 minutes, the default value is 120)

Default Gateway:  (Optional)

Default Domain:  (Optional)

Primary DNS:  (Optional)

Secondary DNS:  (Optional)

Note: The DHCP Settings function cannot be configured if you have chosen Smart IP (DHCP) in Network->LAN (in this situation the device will help you configure the DHCP automatically as you need).

Figure 6-16 DHCP Settings

### 6.6.2 DHCP Client List

Choose menu “**DHCP → DHCP Client List**”, and then you can view the information about the clients attached to the Router in the screen as shown in Figure 6-17.

ID	Client Name	MAC Address	Assigned IP	Lease Time
1	tplink14129	6C-62-6D-F7-31-8D	192.168.0.100	01:15:47
2	Unknown	70-73-CB-1F-C8-C9	192.168.0.101	01:56:32

Figure 6-17 DHCP Client List

- **Client Name** - The name of the DHCP client
- **MAC Address** - The MAC address of the DHCP client
- **Assigned IP** - The IP address that the Router has allocated to the DHCP client
- **Lease Time** - The time of the DHCP client leased. After the dynamic IP address has expired, a new dynamic IP address will be automatically assigned to the user.

You cannot change any of the values on this page. To update this page and to show the current attached devices, click the **Refresh** button.

### 6.6.3 Address Reservation

Choose menu “**DHCP → Address Reservation**”, and then you can view and add a reserved address for clients via the next screen (shown in Figure 6-18). When you specify a reserved IP address for a PC on the LAN, that PC will always receive the same IP address each time when it accesses the DHCP server. Reserved IP addresses should be assigned to the servers that require permanent IP settings.

Address Reservation				
ID	MAC Address	Reserved IP Address	Status	Modify
1	00-11-22-33-44-AA	192.168.0.169	Enabled	<a href="#">Modify</a> <a href="#">Delete</a>

Figure 6-18 Address Reservation

- **MAC Address** - The MAC address of the PC for which you want to reserve an IP address.
- **Reserved IP Address** - The IP address reserved for the PC by the Router.
- **Status** - The status of this entry either **Enabled** or **Disabled**.
- **Modify** - To modify or delete an existing entry.

**To Reserve an IP address:**

1. Click the **Add New...** button. Then Figure 6-18 will pop-up.
2. Enter the MAC address (in XX-XX-XX-XX-XX-XX format) and IP address (in dotted-decimal notation) of the computer for which you want to reserve an IP address.
3. Click the **Save** button.

Add or Modify an Address Reservation Entry	
MAC Address:	<input type="text"/>
Reserved IP Address:	<input type="text"/>
Status:	Enabled <input type="button" value="v"/>
<input type="button" value="Save"/> <input type="button" value="Back"/>	

Figure 6-19 Add or Modify an Address Reservation Entry

**To modify or delete an existing entry:**

1. Click the **Modify** in the entry you want to modify. If you want to delete the entry, click the **Delete**.
2. Modify the information.
3. Click the **Save** button.

Click the **Enable/Disable All** button to make all entries enabled/disabled.

Click the **Delete All** button to delete all entries.

Click the **Next** button to go to the next page and Click the **Previous** button to return the previous page.



## 6.7 USB Settings

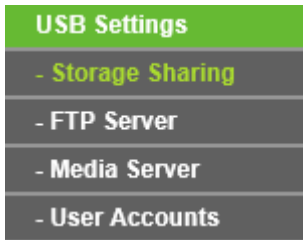

Figure 6-20 The USB Settings menu

There are three submenus under the USB Settings menu (shown in Figure 6-20), **Storage Sharing**, **Media Server** and **User Accounts**. Click any of them, and you will be able to configure the corresponding functions.

### 6.7.1 Storage Sharing

Choose menu “**USB Settings**→**Storage Sharing**”, you can configure a USB disk drive attached to the router and view volume and share such properties as share name, capacity, used space, and free space on this page as shown below.

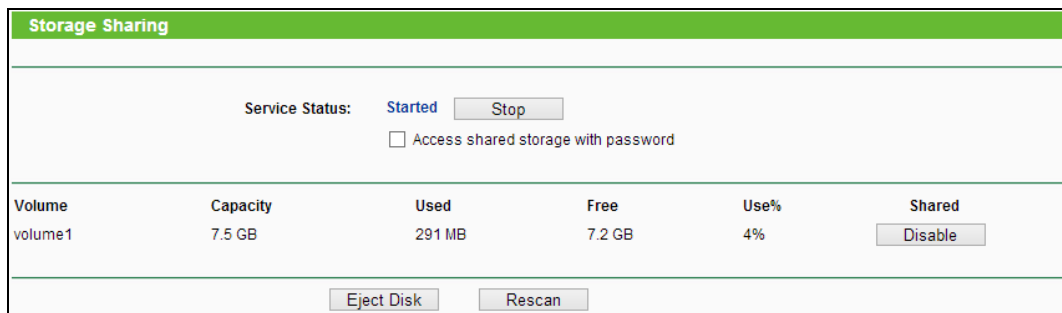

Figure 6-21 Storage Sharing

- **Service Status** - Indicates the Network Sharing service's current status. You can click the **Start** button to start the Storage Sharing service and click the **Stop** button to stop it.
- **Volume** - The volume name of the USB drive the users have access to. Volume 1-8 is mapping to USB port1, and Volume 9-16 is mapping to USB port2.
- **Capacity** - The storage capacity of the USB driver.
- **Used** - The used space of the USB driver.
- **Free** - The available space of the USB driver.
- **Use%** - The percentage of the used space.
- **Shared** - Indicates the shared or non-shared status of the volume. When the volume is shared, you can click the **Disable** to stop sharing the volume; when volume is non-shared, you can click the **Enable** button to share the volume.

Click the **Start** button to start the Network Sharing service.

Click the **Stop** button to stop the Network Sharing service.

Click the **Eject Disk** button to safely remove the USB storage device that is connected to USB port. This takes the drive offline. A message (as shown in Figure 6-22) will appear on your web browser when it is safe to detach the USB disk.

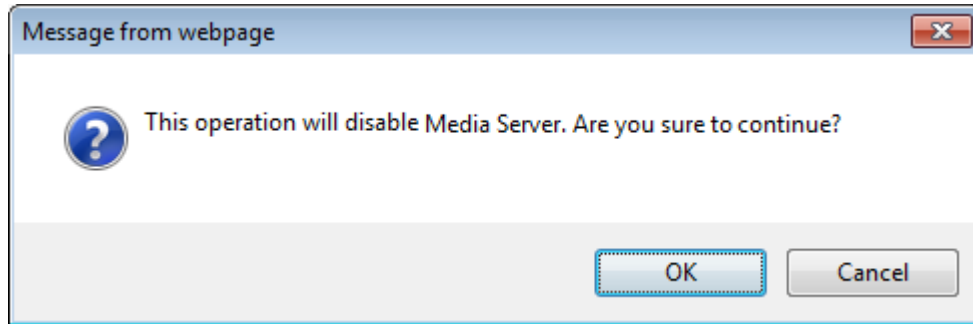

Figure 6-22 Safe Unplug Message

Click the **Rescan** button to start a new scan.

**Follow the instructions below to set up your router as a file server:**

1. Plug an external USB hard disk drive or USB flash drive into this router.
2. Click the **Rescan** button to find the USB drive that has been attached to the router.
3. Click the **Start** button to start the Storage Sharing service.
4. Click the **Enable** button under **Shared** to enable the disk to share.
5. Click the **Open the disk** to visit the sharing disk.

**Note:**

1. The router can automatically locate new USB drive. But to display the information about your USB device, you need to click the **Rescan** button manually.
2. The new settings will not take effect until you restart the service.
3. To unplug the USB drive, click **Eject Disk** button first. Simply pulling USB drive out of the USB port can cause damage to the device and loss of data.
4. Mounted volumes of each USB port are subject to the 8-volume limit. So you cannot access more than 8 volumes on the USB storage device.
5. If you change the storage settings during the storage connection is established, then the changes will not take effect until the router or the client is rebooted.

### 6.7.2 FTP Server

Choose menu "**USB Settings**→**FTP Server**", you can create an FTP server that can be accessed from the Internet or your local network.

FTP Server Configuration

Server Status: **Started**

Internet Access:  Enable  Disable

Service Port:  (The default is 21, do not change unless necessary.)

Internet Address: 192.168.1.104

Name	Partition	Folder	Modify
folder1	volume1	volume1	<a href="#">Edit</a> <a href="#">Delete</a>

Figure 6-23 FTP Server Configuration

- **Service Status** - Indicates the FTP Server's current status.
- **Internet Access** - Select enable to allow access of the FTP server from the Internet. Otherwise, select disable to only allow local network access.
- **Service Port** - Enter the FTP Port number to use. The default is 21.
- **Name** - This folder's display name.
- **Partition** - The volume that the folder resides. Volume 1-8 is mapping to USB port1, and Volume 9-16 is mapping to USB port2.
- **Folder** - The real full path of the specified folder.

**To set up your FTP Server, please follow the instructions below:**

1. Plug an external USB hard disk drive or USB flash drive into this Router.
2. Click the **Enable/Disable** radio box to enable/disable Internet access to FTP from Internet port.
3. Specify a port for the FTP server to use (The default port number is 21).
4. The **Internet Address** displays the WAN IP address of this router, so that other users can access FTP via this address.
5. If WAN type is PPPoE/PPTP/L2TP, two connections will be available. Therefore, users can access FTP server via two connections. Users in a private LAN can access ftp server via **Public Address** while Internet users can access ftp server via **Internet Address**.
6. Click the **Start** button to start the ftp server.

**To add a new folder, follow the instructions below.**

1. Click **Add New Folder** in Figure 6-23.

Figure 6-24 Add or Modify Share Folder

2. Select the **Share entire partition** or a specific folder option.
3. Enter display name of the share folder in **Display Name** field.
4. Click the **Save** button to save the settings.

You can click the **upper** button to go to the upper folder.

You can click the **Back** button to return to the ftp server configuration page.

**Note:**

The max share folders number is 10. If you want to share a new folder when the number has reached 10, you can delete an existing share folder and then add a new one.

If you want to change the FTP settings, you need to restart FTP Server to make the changes take effect.

### 6.7.3 Media Server

Choose menu “**USB Settings**→**Media Server**”, you can create media server that allows you to share stored content with other computers and devices on your home network and on the Internet.

Figure 6-25 Media Server Setting

- **Server Name** - The name of this Media Server.

- **Server Status** - Indicates the Media Server's current status, started or stopped. You can click the **Start** button to start the Media Server and click the **Stop** button to stop it.
- **Name** - The display name of this folder.
- **File System** - The file system type on the partition can be FAT32 or NTFS.
- **Folder** - The real full path of the specified folder.
- **Delete** - You can delete the share folder by click **Delete**.

**To set up your media server, please follow the instructions below:**

1. Plug an external USB hard disk drive or USB flash drive into this router, and then the screen will appear as shown.
2. Click the **Start** button to start the media server.
3. Click the **Add New Folder** button to specify a folder as the search path of media server. The screen will then appear as shown in Figure 6-26.

Figure 6-26 Add New Folder

- **Display Name** - You can enter a display name for the share folder.
- **Share entire partition** - Choose this option and then the folders contained in this partition will all be shared.
- **Folder Location**- Displays the location of this folder.
- **Select** - Check the radio button to select the folder to share.
- **Folder** - Displays folders that are in current path.
- **Upper** - Click this button to get into the upper folder.
- **Save** - Click this button to save your settings and the page will be redirected to the media server configuration page.

- **Back** - Click this button to discard the settings and just go to the media server configuration page.
4. Click the **Scan All** button to scan all the share folders immediately. You can also select the **Auto-scan**, at same time, select an auto scan interval time by drop-down list. In this case, the media server will auto scan the share folders.

 **Note:**

The max share folders number is 6. If you want share a new folder when the number has been reached to be 6, you can delete a share folder and then add a new one.

#### 6.7.4 User Accounts

You can specify the user name and password for Storage Sharing users on this page. **Storage Sharing** users can use Internet Explorer to access files on the USB drive.

There are two default user accounts that can access the Storage Sharing. They are Administrator and Guest (as shown in Figure 6-27). Administrator has read/write access to Storage Sharing and can access FTP Server while Guest has read-only access to Storage Sharing and cannot access FTP Server.

User Account Management				
<input type="button" value="Add New User"/>				
User Name	Password	Storage Authority	FTP Access	Modify
admin	admin	Read and Write	Read and Write	<a href="#">Edit</a>

Figure 6-27 User Account Management

Only Administrator can use a Web browser to transfer the files from a PC to the Writable shared volume on the USB drive.

**To add a new user account, please follow the steps below:**

1. Click **Add New User** button, and the screen will appear as shown in Figure 6-28.
2. Self-define a **User Name**.
3. Enter the password in the **Password** field.
4. Choose the Storage Authority from the drop-down list, **Read and Write** or **Read Only**.

Add or Modify User Account	
User Name:	<input type="text" value="admin1"/>
Password:	<input type="text" value="admin"/>
Storage Authority:	<input type="text" value="Read Only"/> ▼
FTP Access:	<input type="text" value="No"/> ▼
<input type="button" value="Save"/> <input type="button" value="Back"/>	

Figure 6-28 Add or Modify User Account

- **User Name** - Type the user name that you want to give access to the USB drive. The user name must be composed of alphanumeric symbols not exceeding 15 characters in length.
- **Password** - Enter the password in the Password field. The password must be composed of alphanumeric symbols not exceeding 15 characters in length. For security purposes, the password for each user account is not displayed.
- **Storage Authority** - Choose **Read and Write** or **Read Only** from the drop-down list to assign access authority of Storage Sharing to the user.
- **Save** - You can click the **Save** button to save your settings.
- **Back** - You can click the **Back** button to discard the settings and just go to the media server configuration page.

 **Note:**

Please restart the service for the new settings to take effect.

If you cannot use the new user name and password to access the shares, press **Windows logo + R** to open the Run dialog box and type **net use \\192.168.0.254 /delete /yes** and press Enter. (192.168.0.254 is your router's LAN IP address. If the LAN IP of the modem connected with your router is 192.168.1.x, the default LAN IP of the router will automatically switch from 192.168.0.254 to 192.168.1.254 to avoid IP conflict; in this case, please try **net use \\192.168.1.254 /delete /yes**.)

## 6.8 System Tools

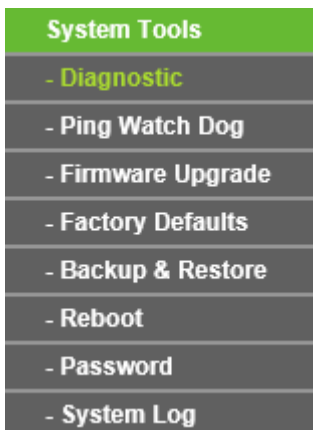

Figure 6-29 The System Tools menu

Choose menu “**System Tools**”, and then you can see the submenus under the main menu: **Diagnostic, Ping Watch Dog, Firmware Upgrade, Factory Defaults, Backup & Restore, Reboot, Password, and System Log**. Click any of them, and you will be able to configure the corresponding function. The detailed explanations for each submenu are provided below.

## 6.8.1 Diagnostic

Choose menu “**System Tools** → **Diagnostic**”, and then you can transact Ping or Traceroute function to check connectivity of your network in the following screen.

The screenshot shows the 'Diagnostic Tools' web interface. It features a green header bar with the text 'Diagnostic Tools'. Below the header is a section titled 'Diagnostic Parameters' containing several configuration options: 'Diagnostic Tool:' with radio buttons for 'Ping' (selected) and 'Traceroute'; 'IP Address/ Domain Name:' with an empty text input field; 'Ping Count:' with a value of '4' and a range '(1-50)'; 'Ping Packet Size:' with a value of '64' and a range '(4-1472 Bytes)'; 'Ping Timeout:' with a value of '800' and a range '(100-2000 Milliseconds)'; and 'Traceroute Max TTL:' with a value of '20' and a range '(1-30)'. Below the parameters is a section titled 'Diagnostic Results' enclosed in a dashed border, containing the text 'This device is ready.'. At the bottom center of the interface is a 'Start' button.

Figure 6-30 Diagnostic Tools

- **Diagnostic Tool** - Check the radio button to select one diagnostic tool.
  - **Ping** - This diagnostic tool troubleshoots connectivity, reachability, and name resolution to a given host or gateway.
  - **Traceroute** - This diagnostic tool tests the performance of a connection.

 **Note:**

You can use ping/traceroute to test both numeric IP address or domain name. If pinging/tracerouting the IP address is successful, but pinging/tracerouting the domain name is not, you might have a name resolution problem. In this case, ensure that the domain name you are specifying can be resolved by using Domain Name System (DNS) queries.

- **IP Address/Domain Name** - Type the destination IP address (e.g. 202.108.22.5) or Domain name (e.g. http://www.tp-link.com).
- **Pings Count** - The number of Ping packets for a Ping connection. The default is 4.
- **Ping Packet Size** - The size of Ping packet. The default is 64.
- **Ping Timeout** - Set the waiting time for the reply of each Ping packet. If there is no reply in the specified time, the connection is overtime. The default is 800.
- **Traceroute Max TTL** - The max number of hops for a Traceroute connection. The default is 20.



Click **Start** to check the connectivity of the Internet.

The **Diagnostic Results** page displays the result of diagnosis.

If the result is similar to the following screen, the connectivity of the Internet is fine.

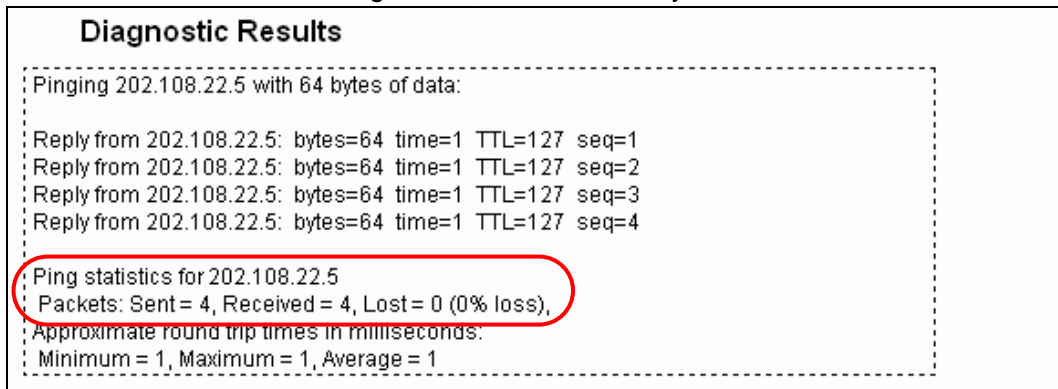

Figure 6-31 Diagnostic Results

**Note:**

Only one user can use this tool at one time. Options “Number of Pings”, “Ping Size” and “Ping Timeout” are used for **Ping** function. Option “Tracert Hops” are used for **Tracert** function.

## 6.8.2 Ping Watch Dog

Choose menu “**System Tools** → **Ping Watch Dog**”, and then you can see the following screen.

Ping Watch Dog Utility	
Enable:	<input checked="" type="checkbox"/>
IP Address:	<input type="text"/>
Interval:	<input type="text" value="300"/> (10-300) seconds
Delay:	<input type="text" value="300"/> (60-300) seconds
Fail Count:	<input type="text" value="3"/> (1-65535)
<input type="button" value="Save"/>	

Figure 6-32 Ping Watch Dog Utility

The **Ping Watch Dog** is dedicated for continuous monitoring of the particular connection to remote host using the Ping tool. It makes this device continuously ping a user defined IP address (it can be the internet gateway for example). If it is unable to ping under the user defined constraints, this device will automatically reboot.

- **Enable** - Turn on/off Ping Watch Dog.
- **IP Address** - The IP address of the target host where the Ping Watch Dog Utility is sending ping packets.
- **Interval** - Time interval between two ping packets which are sent out continuously.
- **Delay** - Time delay before first ping packet is sent out when this device is restarted.

- **Fail Count** - Upper limit of the ping packet this device can drop continuously. If this value is overrun, this device will restart automatically.

Be sure to click the **Save** button to make your settings in operation.

### 6.8.3 Firmware Upgrade

Choose menu “**System Tools** → **Firmware Upgrade**”, and then you can update the latest version of firmware for the Router on the following screen.

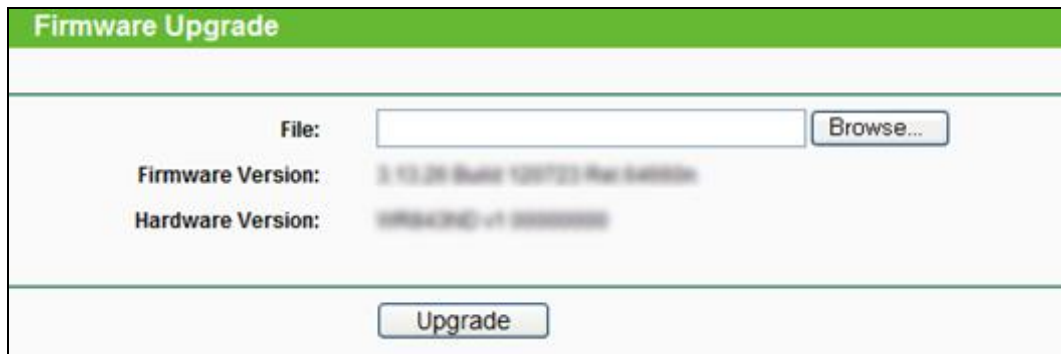

Figure 6-33 Firmware Upgrade

- **Firmware Version** - This displays the current firmware version.
- **Hardware Version** - This displays the current hardware version. The hardware version of the upgrade file must accord with the Router’s current hardware version.

**To upgrade the Router's firmware, follow these instructions below:**

1. Download a more recent firmware upgrade file from the TP-LINK website (<http://www.tp-link.com>).
2. Type the path and file name of the update file into the **File** field, or click the **Browse** button to locate the update file.
3. Click the **Upgrade** button.

 **Note:**

1. New firmware versions are posted at <http://www.tp-link.com> and can be downloaded for free. There is no need to upgrade the firmware unless the new firmware has a new feature you want to use. However, when experiencing problems caused by the Router rather than the configuration, you can try to upgrade the firmware.
2. When you upgrade the Router's firmware, you may lose its current configurations, so before upgrading the firmware please write down some of your customized settings to avoid losing important settings.
3. Do not turn off the Router or press the Reset button while the firmware is being upgraded, otherwise, the Router may be damaged.
4. The Router will reboot after the upgrading has been finished.

## 6.8.4 Factory Defaults

Choose menu “**System Tools** → **Factory Defaults**”, and you can restore the configurations of the Router to factory defaults on the following screen.

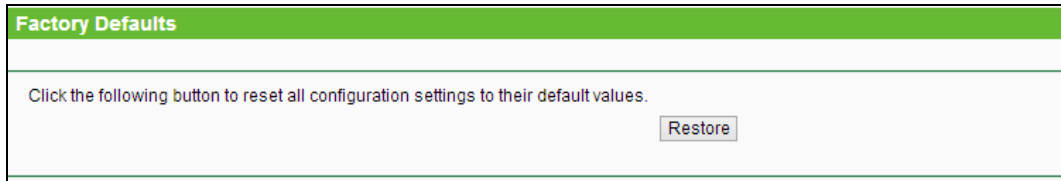

Figure 6-34 Restore Factory Default

Click the **Restore** button to reset all configuration settings to their default values.

- The default **User Name**: admin
- The default **Password**: admin
- The default **IP Address**: 192.168.0.254
- The default **Subnet Mask**: 255.255.255.0

### **Note:**

All changed settings will be lost when defaults are restored.

## 6.8.5 Backup & Restore

Choose menu “**System Tools** → **Backup & Restore**”, and then you can save the current configuration of the Router as a backup file and restore the configuration via a backup file as shown in Figure 6-35.

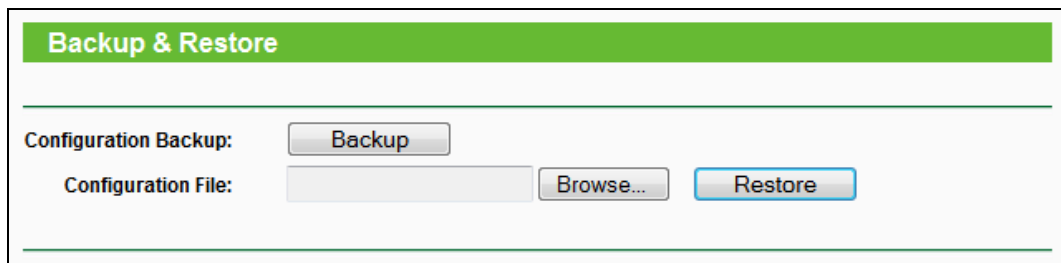

Figure 6-35 Backup & Restore Configuration

- Click the **Backup** button to save all configuration settings as a backup file in your local computer.
- To upgrade the Router's configuration, follow these instructions.
  - Click the **Browse...** button to locate the update file for the Router, or enter the exact path to the Setting file in the text box.
  - Click the **Restore** button.

**Note:**

The current configuration will be covered by the uploading configuration file. The upgrade process lasts for 20 seconds and the Router will restart automatically. Keep the Router on during the upgrading process to prevent any damage.

### 6.8.6 Reboot

Choose menu “**System Tools** → **Reboot**”, and then you can click the **Reboot** button to reboot the Router via the next screen.



Reboot

Click this button to reboot this device.

Reboot

Figure 6-36 Reboot the Router

Some settings of the Router will take effect only after rebooting, including:

- Change the LAN IP Address (system will reboot automatically).
- Change the DHCP Settings.
- Change the Wireless configurations.
- Change the Web Management Port.
- Upgrade the firmware of the Router (system will reboot automatically).
- Restore the Router's settings to factory defaults (system will reboot automatically).
- Update the configuration with the file (system will reboot automatically).

### 6.8.7 Password

Choose menu “**System Tools** → **Password**”, and then you can change the factory default user name and password of the Router in the next screen as shown in Figure 6-37.

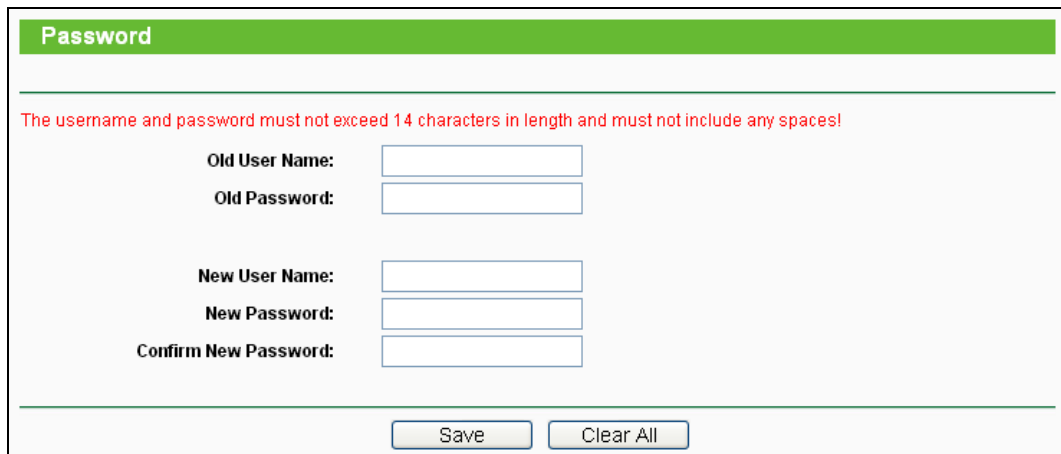

Password

The username and password must not exceed 14 characters in length and must not include any spaces!

Old User Name:

Old Password:

New User Name:

New Password:

Confirm New Password:

Save Clear All

Figure 6-37 Password

It is strongly recommended that you should change the factory default user name and password of the Router, because all users who try to access the Router's Web-based utility or Quick Setup will be prompted for the Router's default user name and password.

**Note:**

The new user name and password must not exceed 14 characters in length and not include any spaces. Enter the new Password twice to confirm.

Click the **Save** button when finished.

Click the **Clear All** button to clear all.

### 6.8.8 System Log

Choose menu “**System Tools** → **System Log**”, and then you can view the logs of the Router.

Figure 6-38 System Log

- **Refresh** - Refresh the page to show the latest log list.
- **Save Log** - Click to save all the logs in a txt file.
- **Mail Log** - Click to send an email of current logs manually according to the address and validation information set in Mail Settings. The result will be shown in the later log soon.
- **Clear Log** - All the logs will be deleted from this device permanently, not just from the page.

## Chapter 7. Configuration for Client Mode

This chapter will show each Web page's key functions and the configuration way for Client Mode of TL-WR810N.

### 7.1 Login

After your successful login, you can configure and manage the device. There are main menus on the left of the web-based utility. Submenus will be available after you click one of the main menus. On the right, there are the corresponding explanations and instructions.

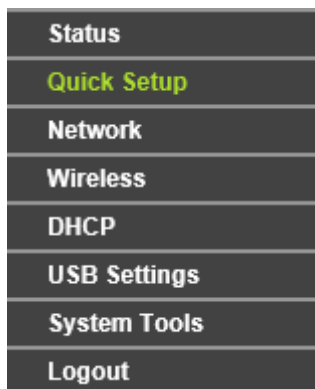

Figure 7-1

The detailed explanations for each Web page's key function are listed below.

### 7.2 Status

The Status page provides the current status information about the Router on Client Mode. All information is read-only.

Status		
Firmware Version:	3.10.8 Build 150918 Rel.43473n	
Hardware Version:	TLWR810N v1 00000000	
Wired		
MAC Address:	00-0A-EB-13-09-19	
IP Address:	192.168.0.254	
Subnet Mask:	255.255.255.0	
Wireless		
Working Mode:	Client	
Wireless Name of Root AP:	TP-LINK_E837	
Channel:	6	
Mode:	11bgn mixed	
Channel Width:	40MHz	
Max Tx Rate:	300Mbps	
MAC Address:	00-0A-EB-13-09-19	
Traffic Statistics		
	Received	Sent
Bytes:	292	676
Packets:	3	2
System Up Time:	0 days 00:05:33	
		<input type="button" value="Refresh"/>

Figure 7-2 Status

- **Firmware Version** - The version information of the Router's firmware.
- **Hardware Version** - The version information of the Router's hardware.
- **Wired** - This field displays the current settings or information for the LAN, you can configure them in the **Network > LAN** page.
  - **MAC address** - The physical address of the Router, as seen from the LAN.
  - **IP address** - The LAN IP address of the Router.
  - **Subnet Mask** - The subnet mask associated with LAN IP address.
- **Wireless** - This field displays basic information or status for wireless function, you can configure them in the **Wireless > Wireless Settings** page.
  - **Working Mode** - The current wireless working mode in use.
  - **Wireless Name of Root AP** - The SSID of Root AP.
  - **Channel** - The current wireless channel in use.
  - **Mode** - The current wireless mode which the Router works on.
  - **Channel Width** - The current wireless channel width in use.
  - **MAC Address** - The physical address of the Router, as seen from the WLAN.
- **Traffic Statistics** - The Router's traffic statistics.

- **Received (Bytes)** - Traffic that counted in bytes has been received out from the WAN port.
  - **Received (Packets)** - Traffic that counted in packets has been received out from the WAN port.
  - **Sent (Bytes)** - Traffic that counted in bytes has been sent out from the WAN port.
  - **Sent (Packets)** - Traffic that counted in packets has been sent out from the WAN port.
- **System Up Time** - The length of the time since the Router was last powered on or reset.

Click the **Refresh** button to get the latest status and settings of the Router.

## 7.3 Quick Setup

Please refer to [Section 3.2: Quick Installation Guide](#).

## 7.4 Network



Figure 7-3 The Network menu

There is only one submenu under the Network menu (shown in Figure 7-3): **LAN**.

### 7.4.1 LAN

Choose menu “**Network** → **LAN**”, and then you can configure the IP parameters of the LAN on the screen as below.

The screenshot shows the LAN configuration interface. At the top is a green header with the text 'LAN'. Below the header, the following fields are visible: 'MAC Address: 00-0A-EB-13-09-19', 'Type: Smart IP(DHCP)' (with a dropdown arrow), 'IP Address: 192.168.0.254', 'Subnet Mask: 255.255.255.0' (with a dropdown arrow), and 'Gateway: 0.0.0.0'. Below these fields is a checkbox labeled 'Allow remote access' which is currently unchecked. A note at the bottom of the form reads: 'Note: The IP parameters cannot be configured if you have chosen Smart IP (DHCP) (In this situation the device will help you configure the IP parameters automatically as you need)'. At the very bottom of the form is a 'Save' button.

Figure 7-4 LAN

- **MAC Address** - The physical address of the LAN ports, as seen from the LAN. The value can't be changed.
- **Type** - Choosing Smart IP (DHCP) to get IP address from DHCP server, or choosing static IP to config IP address manually.
- **IP Address** - Enter the IP address of your system in dotted-decimal notation (factory default - 192.168.0.254).

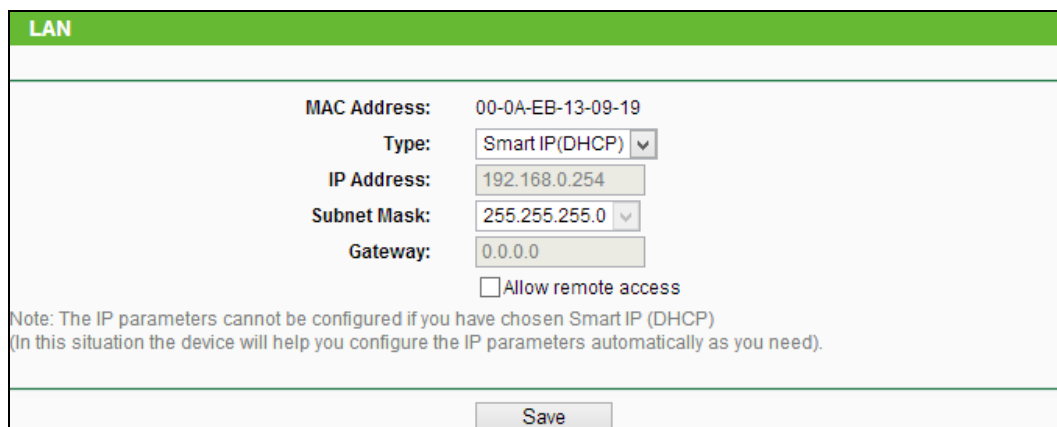

- **Subnet Mask** - An address code that determines the size of the network. Normally 255.255.255.0 is used as the subnet mask.
- **Gateway** - The gateway should be in the same subnet as your IP address.
- **Allow remote access** - Allow remote devices to access the AP device by inputting the IP address in browser.

 **Note:**

1. If you change the IP Address of LAN, you must use the new IP Address to login to the Router.
2. If the new LAN IP Address you set is not in the same subnet with the previous one, the IP Address pool in the DHCP server will be configured automatically, while the Virtual Server and DMZ Host will not take effect until they are re-configured.
3. When you choose the **Smart IP (DHCP)** mode, the DHCP Server function will be disabled.

## 7.5 Wireless

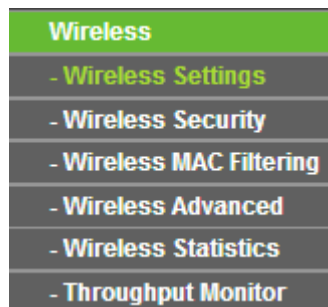

Figure 7-5 Wireless menu

There are six submenus under the Wireless menu: **Wireless Settings**, **Wireless Security**, **Wireless MAC Filtering**, **Wireless Advanced**, **Wireless Statistics** and **Throughput Monitor**. Click any of them, and you will be able to configure the corresponding function.

### 7.5.1 Wireless Settings

Choose menu "**Wireless** → **Wireless Settings**", and then you can configure the basic settings for the wireless network on this page.

Figure 7-6 Wireless Settings - Router

- **Enable WDS** - The AP client can connect to AP with WDS enabled or disabled. If WDS is enabled, all traffic from wired networks will be forwarded in the format of WDS frames consisting of four address fields. If WDS is disabled, three address frames are used. If your AP supports WDS well, please enable this option.
- **Wireless Name of Root AP** - Enter the SSID of AP that you want to access.
- **MAC Address of Root AP** - Enter the MAC address of AP that you want to access.
- **Region** - Select your region from the pull-down list. This field specifies the region where the wireless function of the AP can be used. It may be illegal to use the wireless function of the AP in a region other than one of those specified in this field. If your country or region is not listed, please contact your local government agency for assistance.
- **Survey** - Click this button, you can search the AP which runs in the current channel.

 **Note:**

The operating distance or range of your wireless connection varies significantly based on the physical placement of the AP. For best results, place your AP.

- Near the center of the area in which your wireless stations will operate.
- In an elevated location such as a high shelf.
- Away from the potential sources of interference, such as PCs, microwaves, and cordless phones.
- With the Antenna in the upright position.
- Away from large metal surfaces..

Failure to follow these guidelines can result in significant performance degradation or inability to wirelessly connect to the AP.

## 7.5.2 Wireless Security

Choose menu “**Wireless** → **Wireless Security**”, and then you can configure the security settings of your wireless network.

There are three wireless security modes supported by the Router: WPA/WPA2-Personal, WPA/WPA2-Enterprise and WEP (Wired Equivalent Privacy).

Figure 7-7 Wireless Security

- **Disable Security** - The wireless security function can be enabled or disabled. If disabled, the wireless stations will be able to connect the Router without encryption. But it's strongly recommended to choose one of the following modes to enable security.
- **WPA-PSK/WPA2-Personal** - It's the WPA/WPA2 authentication type based on pre-shared passphrase.
  - **Version** - you can choose the version of the WPA-PSK security on the drop-down list. The default setting is **Automatic**, which can select **WPA-PSK** (Pre-shared key of WPA) or **WPA2-PSK** (Pre-shared key of WPA) automatically based on the wireless station's capability and request.
  - **Encryption** - When **WPA-PSK** or **WPA** is set as the Authentication Type, you can select either **Automatic**, or **TKIP** or **AES** as Encryption.
  - **Wireless Password** - You can enter ASCII or Hexadecimal characters. For Hexadecimal, the length should be between 8 and 64 characters; for ASCII, the length should be between 8 and 63 characters.

- **Group Key Update Period** - Specify the group key update interval in seconds. The value can be either 0 or at least 30. Enter 0 to disable the update.

 **Note:**

If you check the **WPA-PSK/WPA2-PSK** radio button and choose TKIP encryption, you will find a notice in red.

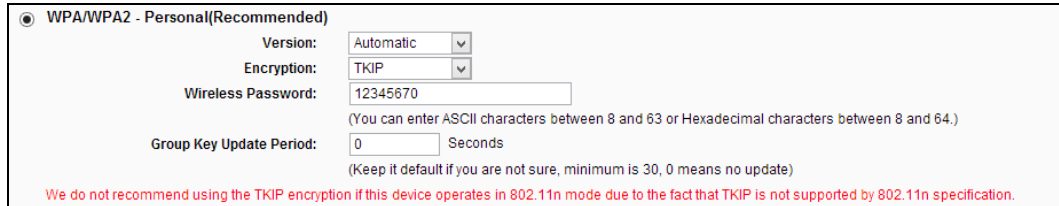

➤ **WPA /WPA2-Enterprise** - It's based on Radius Server.

- **Version** - you can choose the version of the WPA security from the pull-down list. The default setting is **Automatic**, which can select **WPA** (Wi-Fi Protected Access) or **WPA2** (WPA version 2) automatically based on the wireless station's capability and request.
- **Encryption** - You can select **Automatic**, **TKIP** or **AES**.
- **Radius Server IP** - Enter the IP address of the Radius server.
- **Radius Port** - Enter the port that Radius server used.
- **Radius Password** - Enter the password for the Radius server.
- **Group Key Update Period** - Specify the group key update interval in seconds. The value should be 30 or above. Enter 0 to disable the update.

➤ **WEP** - It is based on the IEEE 802.11 standard.

- **Type** - you can choose the type for the WEP security on the pull-down list. The default setting is **Automatic**, which can select **Shared Key** or **Open System** authentication type automatically based on the wireless station's capability and request.
  - **WEP Key Format** - **Hexadecimal** and **ASCII** formats are provided here. **Hexadecimal** format stands for any combination of hexadecimal digits (0-9, a-f, A-F) in the specified length. **ASCII** format stands for any combination of keyboard characters in the specified length.
  - **WEP Key (Password)** - Select which of the four keys will be used and enter the matching WEP key that you create. Make sure these values are identical on all wireless stations in your network.
  - **Key Type** - You can select the WEP key length (64-bit, or 128-bit, or 152-bit.) for encryption. "Disabled" means this WEP key entry is invalid.
- 64-bit** - You can enter 10 hexadecimal digits (any combination of 0-9, a-f, A-F, and null key is not permitted) or 5 ASCII characters.

**128-bit** - You can enter 26 hexadecimal digits (any combination of 0-9, a-f, A-F, and null key is not permitted) or 13 ASCII characters.

**152-bit** - You can enter 32 hexadecimal digits (any combination of 0-9, a-f, A-F, and null key is not permitted) or 16 ASCII characters.

 **Note:**

If you do not set the key, the wireless security function is still disabled even if you have selected Shared Key as Authentication Type.

Be sure to click the **Save** button to save your settings on this page.

### 7.5.3 Wireless MAC Filtering

Choose menu "**Wireless** → **Wireless MAC Filtering**", and then you can control the wireless access by configuring the **Wireless MAC Filtering** function as shown in.

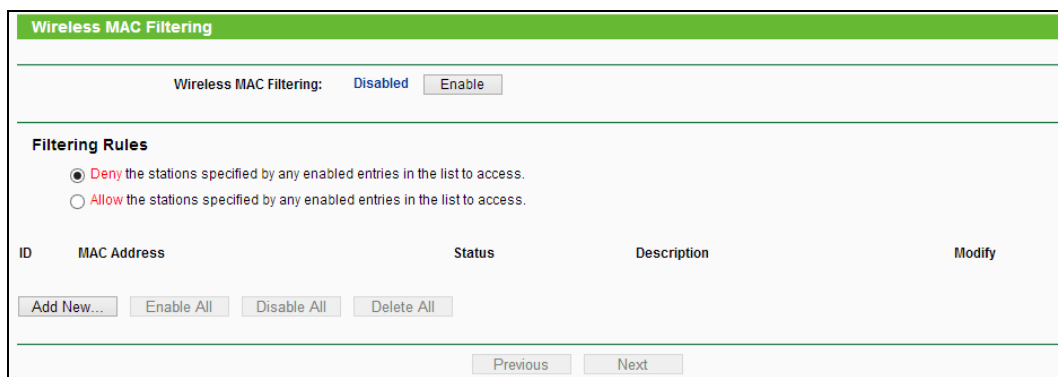

Figure 7-8 Wireless MAC Filtering

To filter wireless users by MAC Address, click **Enable**. The default setting is **Disable**.

- **MAC Address** - The wireless station's MAC address that you want to access.
- **Status** - The status of this entry, either **Enabled** or **Disable**.
- **Description** - A simple description of the wireless station.

To Add a Wireless MAC Address filtering entry, click the **Add New...** button. The "**Add or Modify Wireless MAC Address Filtering entry**" page will appear, shown in Figure 7-9:

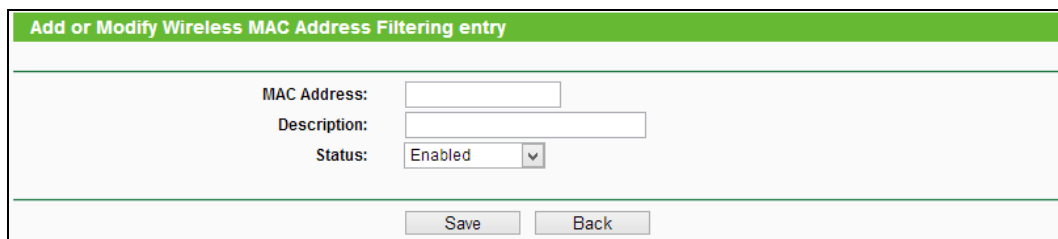

Figure 7-9 Add or Modify Wireless MAC Address Filtering entry

**To add or modify a MAC Address Filtering entry, follow these instructions:**

1. Enter the appropriate MAC Address into the **MAC Address** field. The format of the MAC Address is XX-XX-XX-XX-XX-XX (X is any hexadecimal digit). For example: 00-0A-EB-B0-00-0B.
2. Give a simple description for the wireless station in the **Description** field. For example: Wireless station A.
3. Select **Enabled** or **Disabled** for this entry on the **Status** pull-down list.
4. Click the **Save** button to save this entry.

**To modify an existing entry:**

1. Click the **Modify** in the entry you want to modify.
2. Modify the information.
3. Click the **Save** button.

Click the **Delete** in the entry you want to delete to delete an existing entry.

Click the **Enable All** button to make all entries enabled

Click the **Disable All** button to make all entries disabled.

Click the **Delete All** button to delete all entries.

Click the **Next** button to go to the next page.

Click the **Previous** button to return to the previous page.

**For example:** If you desire that the wireless station A with MAC address 00-0A-EB-B0-00-0B and the wireless station B with MAC address 00-0A-EB-00-07-5F are able to access the Router, but all the other wireless stations cannot access the Router, you can configure the **Wireless MAC Address Filtering** list by following these steps:

1. Click the **Enabled** button to enable this function.
2. Select the radio button "Allow the stations specified by any enabled entries in the list to access" for **Filtering Rules**.
3. Delete all or disable all entries if there are any entries already.
4. Click the **Add New...** button.
  - 1) Enter the MAC address 00-0A-EB-B0-00-0B/00-0A-EB-00-07-5F in the **MAC Address** field.
  - 2) Enter wireless station A/B in the **Description** field.
  - 3) Select **Enabled** in the **Status** pull-down list.
  - 4) Click the **Save** button.
  - 5) Click the **Back** button.

The filtering rules that configured should be similar to the following list:

### Filtering Rules

Deny the stations specified by any enabled entries in the list to access.

Allow the stations specified by any enabled entries in the list to access.

ID	MAC Address	Status	Description	Modify
1	00-0A-EB-B0-00-0B	Enabled	wireless station A	<a href="#">Modify</a> <a href="#">Delete</a>
2	00-0A-EB-00-07-5F	Enabled	wireless station B	<a href="#">Modify</a> <a href="#">Delete</a>

## 7.5.4 Wireless Advanced

Choose menu “**Wireless** → **Wireless Advanced**”, and then you can configure the advanced settings of your wireless network.

### Wireless Advanced

Transmit Power:  (40-1000)

Beacon Interval:  (40-1000)

RTS Threshold:  (256-2346)

Fragmentation Threshold:  (256-2346)

DTIM Interval:  (1-255)

Enable WMM  
 Enable Short GI  
 Enable AP Isolation

Figure 7-10 Wireless Advanced

- **Transmit Power** - Here you can specify the transmit power of Router. You can select High, Middle or Low which you would like. High is the default setting and is recommended.
- **Beacon Interval** - Enter a value between 20-1000 milliseconds for Beacon Interval here. The beacons are the packets sent by the Router to synchronize a wireless network. Beacon Interval value determines the time interval of the beacons. The default value is 100.
- **RTS Threshold** - Here you can specify the RTS (Request to Send) Threshold. If the packet is larger than the specified RTS Threshold size, the Router will send RTS frames to a particular receiving station and negotiate the sending of a data frame. The default value is 2346.
- **Fragmentation Threshold** - This value is the maximum size determining whether packets will be fragmented. Setting the Fragmentation Threshold too low may result in poor network performance because of excessive packets. 2346 is the default setting and is recommended.
- **DTIM Interval** - This value determines the interval of the Delivery Traffic Indication Message (DTIM). A DTIM field is a countdown field informing clients of the next window for listening to broadcast and multicast messages. When the Router has buffered broadcast or multicast messages for associated clients, it sends the next DTIM with a DTIM Interval value. You can

specify the value between 1-255 Beacon Intervals. The default value is 1, which indicates the DTIM Interval is the same as Beacon Interval.

- **Enable WMM - WMM** function can guarantee the packets with high-priority messages being transmitted preferentially. It is strongly recommended enabled.
- **Enable Short GI** - This function is recommended for it will increase the data capacity by reducing the guard interval time.
- **Enable AP Isolation** - This function isolate all connected wireless stations so that wireless stations cannot access each other through WLAN. This function will be disabled if WDS/Bridge is enabled.

#### **Note:**

If you are not familiar with the setting items in this page, it's strongly recommended to keep the provided default values; otherwise it may result in lower wireless network performance.

### 7.5.5 Wireless Statistics

Choose menu “**Wireless** → **Wireless Statistics**”, and then you can see the MAC Address, Current Status, Received Packets and Sent Packets for each connected wireless station.

Wireless Statistics					
Current Connected Wireless Stations numbers: 1					Refresh
ID	MAC Address	Current Status	Received Packets	Sent Packets	Configure
1	70-73-CB-1F-C8-C9	STA-ASSOC	46	16	Allow

Previous      Next

Figure 7-11 Wireless Statistics

- **MAC Address** - The connected wireless station's MAC address
- **Current Status** - The connected wireless station's running status, one of **STA-AUTH / STA-ASSOC / STA-JOINED / WPA / WPA-PSK / WPA2 / WPA2-PSK / AP-UP / AP-DOWN / Disconnected**
- **Received Packets** - Packets received by the station
- **Sent Packets** - Packets sent by the station.
- **Configure** - The button is used for loading the item to the **Wireless MAC Filtering** list.
  - **Allow** - If the **Wireless MAC Filtering** function enable, allow the station to access.
  - **Deny** - If the **Wireless MAC Filtering** function enable, deny the station to access.



You cannot change any of the values on this page. To update this page and to show the current connected wireless stations, click on the **Refresh** button.

If the numbers of connected wireless stations go beyond one page, click the **Next** button to go to the next page and click the **Previous** button to return the previous page.

 **Note:**

This page will be refreshed automatically every 5 seconds.

### 7.5.6 Throughput Monitor

Choose menu “**Wireless** → **Throughput Monitor**”, and then you can see the wireless throughput info.

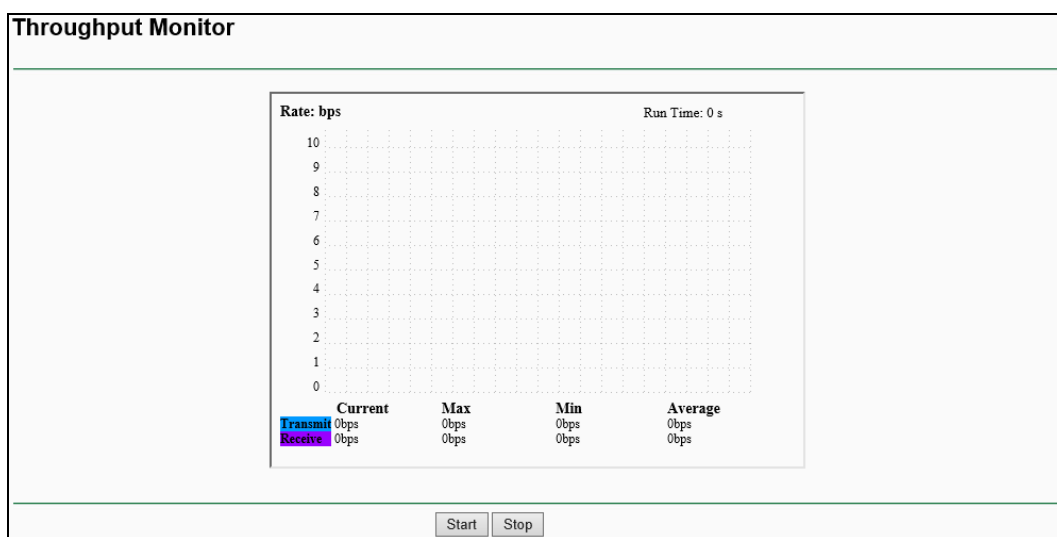

Figure 7-12 Wireless Statistics

- **Rate** - The Throughput unit.
- **Run Time** - How long this function is running.
- **Transmit** - Wireless transmit rate information.
- **Receive** - Wireless receive rate information.

Click the **Start** button to start wireless throughput monitor.

Click the **Stop** button to stop wireless throughput monitor.

## 7.6 DHCP

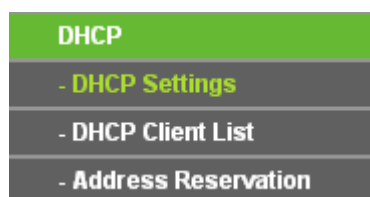

Figure 7-13 The DHCP menu

There are three submenus under the DHCP menu (shown in Figure 7-13), **DHCP Settings**, **DHCP Client List** and **Address Reservation**. Click any of them, and you will be able to configure the corresponding function.

### 7.6.1 DHCP Settings

Choose menu “**DHCP** → **DHCP Settings**”, and then you can configure the DHCP Server on the page as shown in Figure 7-14. The Router is set up by default as a DHCP (Dynamic Host Configuration Protocol) server, which provides the TCP/IP configuration for all the PC(s) that are connected to the Router in the LAN.

DHCP Settings	
DHCP Server:	<input checked="" type="radio"/> Disable <input type="radio"/> Enable
Start IP Address:	<input type="text" value="192.168.0.100"/>
End IP Address:	<input type="text" value="192.168.0.199"/>
Address Lease Time:	<input type="text" value="120"/> minutes (1~2880 minutes, the default value is 1 minute)
Default Gateway:	<input type="text" value="192.168.0.254"/> (Optional)
Default Domain:	<input type="text"/> (Optional)
Primary DNS:	<input type="text" value="0.0.0.0"/> (Optional)
Secondary DNS:	<input type="text" value="0.0.0.0"/> (Optional)
<input type="button" value="Save"/>	

Figure 7-14 DHCP Settings

- **DHCP Server - Enable or Disable** the DHCP server. If you disable the Server, you must have another DHCP server within your network or else you must configure the computer manually.
- **Start IP Address** - Specify an IP address for the DHCP Server to start with when assigning IP addresses. 192.168.0.100 is the default start address.
- **End IP Address** - Specify an IP address for the DHCP Server to end with when assigning IP addresses. 192.168.0.199 is the default end address.
- **Address Lease Time** - The **Address Lease Time** is the amount of time a network user will be allowed connection to the Router with their current dynamic IP Address. Enter the amount of time in minutes and the user will be "leased" this dynamic IP Address. After the time is up, the user will be automatically assigned a new dynamic IP address. The range of the time is 1 ~ 2880 minutes. The default value is 120 minutes.
- **Default Gateway (Optional)** - It is suggested to input the IP address of the LAN port of the Router. The default value is 192.168.0.254.
- **Default Domain (Optional)** - Input the domain name of your network.
- **Primary DNS - (Optional)** Input the DNS IP address provided by your ISP or consult your ISP.

- **Secondary DNS** (Optional) - Input the IP address of another DNS server if your ISP provides two DNS servers.

 **Note:**

1. To use the DHCP server function of the Router, you must configure all computers on the LAN as "Obtain an IP Address automatically". This function will take effect until this device reboots.
2. When you choose the **Smart IP (DHCP)** mode in **Network** → **LAN**, the DHCP Server function will be disabled. You will see the page as below.

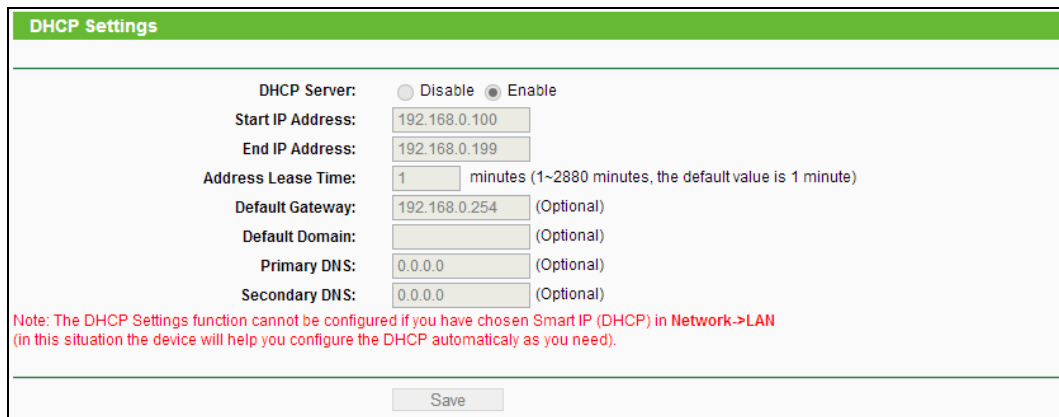

**DHCP Settings**

DHCP Server:  Disable  Enable

Start IP Address:

End IP Address:

Address Lease Time:  minutes (1~2880 minutes, the default value is 1 minute)

Default Gateway:  (Optional)

Default Domain:  (Optional)

Primary DNS:  (Optional)

Secondary DNS:  (Optional)

Note: The DHCP Settings function cannot be configured if you have chosen Smart IP (DHCP) in Network->LAN (in this situation the device will help you configure the DHCP automatically as you need).

Figure 7-15 DHCP Settings

## 7.6.2 DHCP Client List

Choose menu “**DHCP** → **DHCP Client List**”, and then you can view the information about the clients attached to the Router in the screen as shown in Figure 7-16.

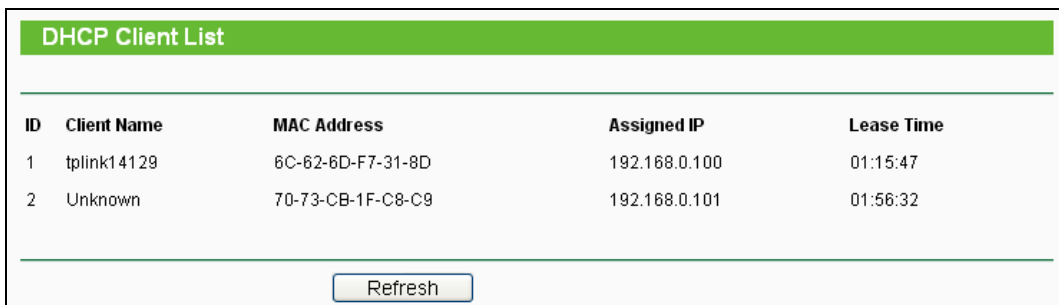

**DHCP Client List**

ID	Client Name	MAC Address	Assigned IP	Lease Time
1	tplink14129	6C-62-6D-F7-31-8D	192.168.0.100	01:15:47
2	Unknown	70-73-CB-1F-C8-C9	192.168.0.101	01:56:32

Figure 7-16 DHCP Clients List

- **Client Name** - The name of the DHCP client
- **MAC Address** - The MAC address of the DHCP client
- **Assigned IP** - The IP address that the Router has allocated to the DHCP client
- **Lease Time** - The time of the DHCP client leased. After the dynamic IP address has expired, a new dynamic IP address will be automatically assigned to the user.

You cannot change any of the values on this page. To update this page and to show the current attached devices, click the **Refresh** button.

### 7.6.3 Address Reservation

Choose menu “**DHCP → Address Reservation**”, and then you can view and add a reserved address for clients via the next screen (shown in Figure 7-17). When you specify a reserved IP address for a PC on the LAN, that PC will always receive the same IP address each time when it accesses the DHCP server. Reserved IP addresses should be assigned to the servers that require permanent IP settings.

ID	MAC Address	Reserved IP Address	Status	Modify
1	00-11-22-33-44-AA	192.168.0.169	Enabled	<a href="#">Modify</a> <a href="#">Delete</a>

Buttons: Add New..., Enable All, Disable All, Delete All

Navigation: Previous, Next

Figure 7-17 Address Reservation

- **MAC Address** - The MAC address of the PC for which you want to reserve an IP address.
- **Reserved IP Address** - The IP address reserved for the PC by the Router.
- **Status** - The status of this entry either **Enabled** or **Disabled**.
- **Modify** - To modify or delete an existing entry.

#### To Reserve an IP address:

1. Click the **Add New...** button. Then Figure 7-18 will pop-up.
2. Enter the MAC address (in XX-XX-XX-XX-XX-XX format.) and IP address (in dotted-decimal notation) of the computer for which you want to reserve an IP address.
3. Click the **Save** button.

MAC Address:

Reserved IP Address:

Status:

Buttons: Save, Back

Figure 7-18 Add or Modify an Address Reservation Entry

#### To modify an existing entry:

1. Click the **Modify** in the entry you want to modify.
2. Modify the information.
3. Click the **Save** button.

Click the **Delete** in the entry you want to delete to delete an existing entry.

Click the **Enable/Disable All** button to make all entries enabled/disabled

Click the **Delete All** button to delete all entries.

Click the **Next** button to go to the next page and Click the **Previous** button to return the previous page.

## 7.7 USB Settings

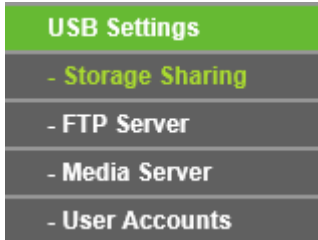

Figure 7-19 The USB Settings menu

There are three submenus under the USB Settings menu (shown in Figure 7-19), **Storage Sharing**, **Media Server** and **User Accounts**. Click any of them, and you will be able to configure the corresponding functions.

### 7.7.1 Storage Sharing

Choose menu “**USB Settings**→**Storage Sharing**”, you can configure a USB disk drive attached to the router and view volume and share such properties as share name, capacity, used space, and free space on this page as shown below.

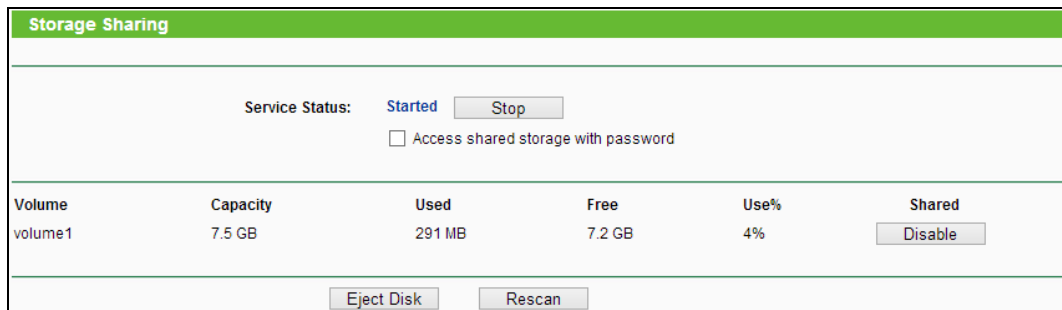

Figure 7-20 Storage Sharing

- **Service Status** - Indicates the Network Sharing service's current status. You can click the **Start** button to start the Storage Sharing service and click the **Stop** button to stop it.
- **Volume** - The volume name of the USB drive the users have access to. Volume 1-8 is mapping to USB port1, and Volume 9-16 is mapping to USB port2.
- **Capacity** - The storage capacity of the USB driver.
- **Used** - The used space of the USB driver.
- **Free** - The available space of the USB driver.
- **Use%** - The percentage of the used space.

- **Shared** - Indicates the shared or non-shared status of the volume. When the volume is shared, you can click the **Disable** to stop sharing the volume; when volume is non-shared, you can click the **Enable** button to share the volume.

Click the **Start** button to start the Network Sharing service.

Click the **Stop** button to stop the Network Sharing service.

Click the **Eject Disk** button to safely remove the USB storage device that is connected to USB port. This takes the drive offline. A message (as shown in Figure 7-21) will appear on your web browser when it is safe to detach the USB disk.

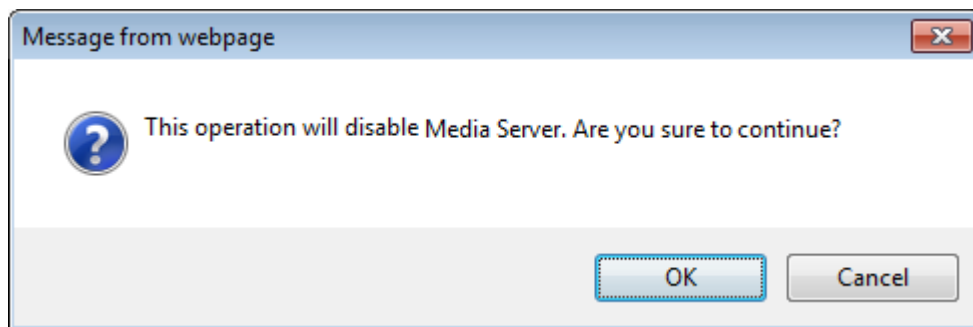

Figure 7-21 Safe Unplug Message

Click the **Rescan** button to start a new scan.

**Follow the instructions below to set up your router as a file server:**

1. Plug an external USB hard disk drive or USB flash drive into this router.
2. Click the **Rescan** button to find the USB drive that has been attached to the router.
3. Click the **Start** button to start the Storage Sharing service.
4. Click the **Enable** button under **Shared** to enable the disk to share.
5. Click the **Open the disk** to visit the sharing disk.

**Note:**

1. The router can automatically locate new USB drive. But to display the information about your USB device, you need to click the **Rescan** button manually.
2. The new settings will not take effect until you restart the service.
3. To unplug the USB drive, click **Eject Disk** button first. Simply pulling USB drive out of the USB port can cause damage to the device and loss of data.
4. Mounted volumes of each USB port are subject to the 8-volume limit. So you cannot access more than 8 volumes on the USB storage device.
5. If you change the storage settings during the storage connection is established, then the changes will not take effect until the router or the client is rebooted.

## 7.7.2 FTP Server

Choose menu “**USB Settings**→**FTP Server**”, you can create an FTP server that can be accessed from the Internet or your local network.

Name	Partition	Folder	Modify
folder1	volume1	volume1	<a href="#">Edit</a> <a href="#">Delete</a>

Figure 7-22 FTP Server Configuration

- **Service Status** - Indicates the FTP Server's current status.
- **Internet Access** - Select enable to allow access of the FTP server from the Internet. Otherwise, select disable to only allow local network access.
- **Service Port** - Enter the FTP Port number to use. The default is 21.
- **Name** - This folder's display name.
- **Partition** - The volume that the folder resides. Volume 1-8 is mapping to USB port1, and Volume 9-16 is mapping to USB port2.
- **Folder** - The real full path of the specified folder.

### To set up your FTP Server, please follow the instructions below:

1. Plug an external USB hard disk drive or USB flash drive into this Router.
2. Click the **Enable/Disable** radio box to enable/disable Internet access to FTP from Internet port.
3. Specify a port for the FTP server to use (The default port number is 21).
4. The **Internet Address** displays the WAN IP address of this router, so that other users can access FTP via this address.
5. If WAN type is PPPoE/PPTP/L2TP, two connections will be available. Therefore, users can access FTP server via two connections. Users in a private LAN can access ftp server via **Public Address** while Internet users can access ftp server via **Internet Address**.
6. Click the **Start** button to start the ftp server.

### To add a new folder, follow the instructions below.

1. Click **Add New Folder** in Figure 7-22.

Figure 7-23 Add or Modify Share Folder

2. Select the **Share entire partition** or a specific folder option.
3. Enter display name of the share folder in **Display Name** field.
4. Click the **Save** button to save the settings.

You can click the **upper** button to go to the upper folder.

You can click the **Back** button to return to the ftp server configuration page.

**Note:**

The max share folders number is 10. If you want to share a new folder when the number has reached 10, you can delete an existing share folder and then add a new one.

If you want to change the FTP settings, you need to restart FTP Server to make the changes take effect.

### 7.7.3 Media Server

Choose menu “**USB Settings→Media Server**”, you can create media server that allows you to share stored content with other computers and devices on your home network and on the Internet.

Figure 7-24 Media Server Setting

- **Server Name** - The name of this Media Server.
- **Server Status** - Indicates the Media Server’s current status, started or stopped. You can click the **Start** button to start the Media Server and click the **Stop** button to stop it.



- **Name** - The display name of this folder.
- **File System** - The file system type on the partition can be FAT32 or NTFS.
- **Folder** - The real full path of the specified folder.
- **Delete** - You can delete the share folder by click **Delete**.

**To set up your media server, please follow the instructions below:**

1. Plug an external USB hard disk drive or USB flash drive into this router, and then the screen will appear as shown.
2. Click the **Start** button to start the media server.
3. Click the **Add New Folder** button to specify a folder as the search path of media server. The screen will then appear as shown in Figure 7-25.

Figure 7-25 Add New Folder

- **Display Name** - You can enter a display name for the share folder.
- **Share entire partition** - Choose this option and then the folders contained in this partition will all be shared.
- **Folder Location**- Displays the location of this folder.
- **Select** - Check the radio button to select the folder to share.
- **Folder** - Displays folders that are in current path.
- **Upper** - Click this button to get into the upper folder.
- **Save** - Click this button to save your settings and the page will be redirected to the media server configuration page.
- **Back** - Click this button to discard the settings and just go to the media server configuration page.

- Click the **Scan All** button to scan all the share folders immediately. You can also select the **Auto-scan**, at same time, select an auto scan interval time by drop-down list. In this case, the media server will auto scan the share folders.

 **Note:**

The max share folders number is 6. If you want share a new folder when the number has been reached to be 6, you can delete a share folder and then add a new one.

#### 7.7.4 User Accounts

You can specify the user name and password for Storage Sharing users on this page. **Storage Sharing** users can use Internet Explorer to access files on the USB drive.

There are two default user accounts that can access the Storage Sharing. They are Administrator and Guest (as shown in Figure 7-26). Administrator has read/write access to Storage Sharing and can access FTP Server while Guest has read-only access to Storage Sharing and cannot access FTP Server.

User Account Management				
<a href="#">Add New User</a>				
User Name	Password	Storage Authority	FTP Access	Modify
admin	admin	Read and Write	Read and Write	<a href="#">Edit</a>

Figure 7-26 User Account Management

Only Administrator can use a Web browser to transfer the files from a PC to the Writable shared volume on the USB drive.

**To add a new user account, please follow the steps below:**

- Click **Add New User** button, and the screen will appear as shown in Figure 7-27.
- Self-define a **User Name**.
- Enter the password in the **Password** field.
- Choose the Storage Authority from the drop-down list, **Read and Write** or **Read Only**.

Add or Modify User Account	
User Name:	<input type="text" value="admin1"/>
Password:	<input type="text" value="admin"/>
Storage Authority:	<input type="text" value="Read Only"/> ▼
FTP Access:	<input type="text" value="No"/> ▼
<input type="button" value="Save"/> <input type="button" value="Back"/>	

Figure 7-27 Add or Modify User Account

- **User Name** - Type the user name that you want to give access to the USB drive. The user name must be composed of alphanumeric symbols not exceeding 15 characters in length.

- **Password** - Enter the password in the Password field. The password must be composed of alphanumeric symbols not exceeding 15 characters in length. For security purposes, the password for each user account is not displayed.
- **Storage Authority** - Choose **Read and Write** or **Read Only** from the drop-down list to assign access authority of Storage Sharing to the user.
- **Save** - You can click the **Save** button to save your settings.
- **Back** - You can click the **Back** button to discard the settings and just go to the media server configuration page.

 **Note:**

Please restart the service for the new settings to take effect.

If you cannot use the new user name and password to access the shares, press **Windows logo + R** to open the Run dialog box and type **net use \\192.168.0.254 /delete /yes** and press Enter. (192.168.0.254 is your router's LAN IP address. If the LAN IP of the modem connected with your router is 192.168.1.x, the default LAN IP of the router will automatically switch from 192.168.0.254 to 192.168.1.254 to avoid IP conflict; in this case, please try **net use \\192.168.1.254 /delete /yes**.)

## 7.8 System Tools



Figure 7-28 The System Tools menu

Choose menu "**System Tools**", and then you can see the submenus under the main menu: **Diagnostic**, **Ping Watch Dog**, **Firmware Upgrade**, **Factory Defaults**, **Backup & Restore**, **Reboot**, **Password**, and **System Log**. Click any of them, and you will be able to configure the corresponding function. The detailed explanations for each submenu are provided below.

### 7.8.1 Diagnostic

Choose menu "**System Tools** → **Diagnostic**", and then you can transact Ping or Traceroute function to check connectivity of your network in the following screen.

Figure 7-29 Diagnostic Tools

- **Diagnostic Tool** - Check the radio button to select one diagnostic tool.
  - **Ping** - This diagnostic tool troubleshoots connectivity, reachability, and name resolution to a given host or gateway.
  - **Traceroute** - This diagnostic tool tests the performance of a connection.

 **Note:**

You can use ping/traceroute to test both numeric IP address or domain name. If pinging/tracerouting the IP address is successful, but pinging/tracerouting the domain name is not, you might have a name resolution problem. In this case, ensure that the domain name you are specifying can be resolved by using Domain Name System (DNS) queries.

- **IP Address/Domain Name** - Type the destination IP address (e.g. 202.108.22.5) or Domain name (e.g.http://www.tp-link.com).
- **Pings Count** - The number of Ping packets for a Ping connection. The default is 4.
- **Ping Packet Size** - The size of Ping packet. The default is 64.
- **Ping Timeout** - Set the waiting time for the reply of each Ping packet. If there is no reply in the specified time, the connection is overtime. The default is 800.
- **Traceroute Max TTL** - The max number of hops for a Traceroute connection. The default is 20.

Click **Start** to check the connectivity of the Internet.

The **Diagnostic Results** page displays the result of diagnosis.

If the result is similar to the following screen, the connectivity of the Internet is fine.

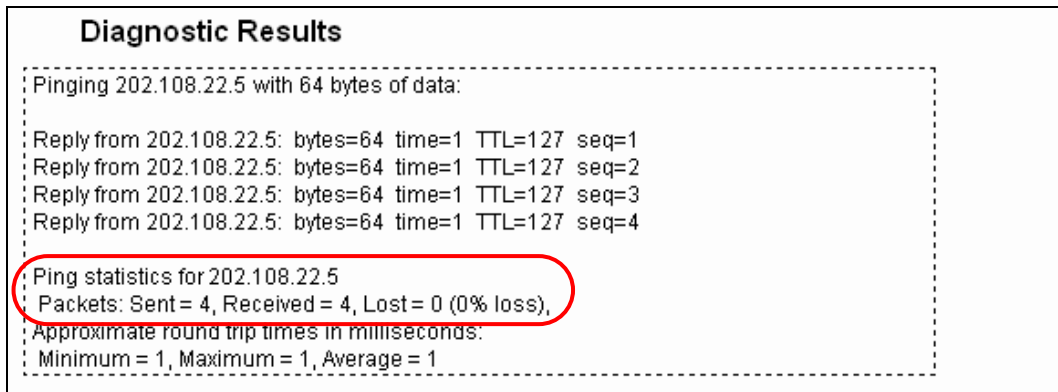

Figure 7-30 Diagnostic Results

**Note:**

Only one user can use this tool at one time. Options “Number of Pings”, “Ping Size” and “Ping Timeout” are used for **Ping** function. Option “Tracert Hops” are used for **Tracert** function.

## 7.8.2 Ping Watch Dog

Choose menu “**System Tools** → **Ping Watch Dog**”, and then you can see the following screen.

Ping Watch Dog Utility	
Enable:	<input checked="" type="checkbox"/>
IP Address:	<input type="text"/>
Interval:	<input type="text" value="300"/> (10-300) seconds
Delay:	<input type="text" value="300"/> (60-300) seconds
Fail Count:	<input type="text" value="3"/> (1-65535)
<input type="button" value="Save"/>	

Figure 7-31 Ping Watch Dog Utility

The **Ping Watch Dog** is dedicated for continuous monitoring of the particular connection to remote host using the Ping tool. It makes this device continuously ping a user defined IP address (it can be the internet gateway for example). If it is unable to ping under the user defined constraints, this device will automatically reboot.

- **Enable** - Turn on/off Ping Watch Dog.
- **IP Address** - The IP address of the target host where the Ping Watch Dog Utility is sending ping packets.
- **Interval** - Time interval between two ping packets which are sent out continuously.
- **Delay** - Time delay before first ping packet is sent out when this device is restarted.
- **Fail Count** - Upper limit of the ping packet this device can drop continuously. If this value is overrun, this device will restart automatically.

Be sure to click the **Save** button to make your settings in operation.

### 7.8.3 Firmware Upgrade

Choose menu “**System Tools** → **Firmware Upgrade**”, and then you can update the latest version of firmware for the Router on the following screen.

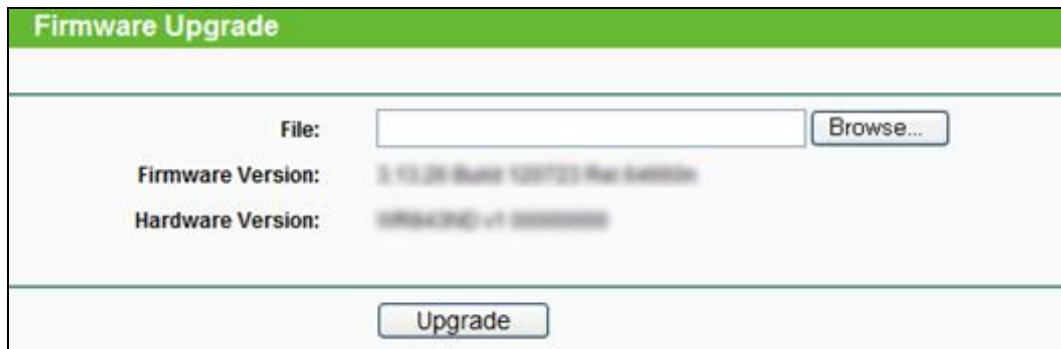

Figure 7-32 Firmware Upgrade

- **Firmware Version** - This displays the current firmware version.
- **Hardware Version** - This displays the current hardware version. The hardware version of the upgrade file must accord with the Router’s current hardware version.

**To upgrade the Router's firmware, follow these instructions below:**

1. Download a more recent firmware upgrade file from the TP-LINK website (<http://www.tp-link.com>).
2. Type the path and file name of the update file into the **File** field, or click the **Browse** button to locate the update file.
3. Click the **Upgrade** button.

 **Note:**

1. New firmware versions are posted at <http://www.tp-link.com> and can be downloaded for free. There is no need to upgrade the firmware unless the new firmware has a new feature you want to use. However, when experiencing problems caused by the Router rather than the configuration, you can try to upgrade the firmware.
2. When you upgrade the Router's firmware, you may lose its current configurations, so before upgrading the firmware please write down some of your customized settings to avoid losing important settings.
3. Do not turn off the Router or press the Reset button while the firmware is being upgraded, otherwise, the Router may be damaged.
4. The Router will reboot after the upgrading has been finished.

## 7.8.4 Factory Defaults

Choose menu “**System Tools** → **Factory Defaults**”, and you can restore the configurations of the Router to factory defaults on the following screen.

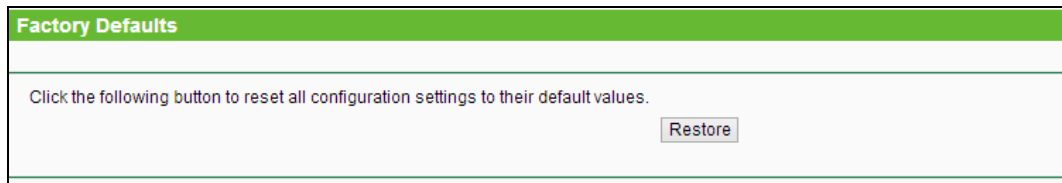

Figure 7-33 Restore Factory Default

Click the **Restore** button to reset all configuration settings to their default values.

- The default **User Name**: admin
- The default **Password**: admin
- The default **IP Address**: 192.168.0.254
- The default **Subnet Mask**: 255.255.255.0

 **Note:**

All changed settings will be lost when defaults are restored.

## 7.8.5 Backup & Restore

Choose menu “**System Tools** → **Backup & Restore**”, and then you can save the current configuration of the Router as a backup file and restore the configuration via a backup file as shown in Figure 7-34.

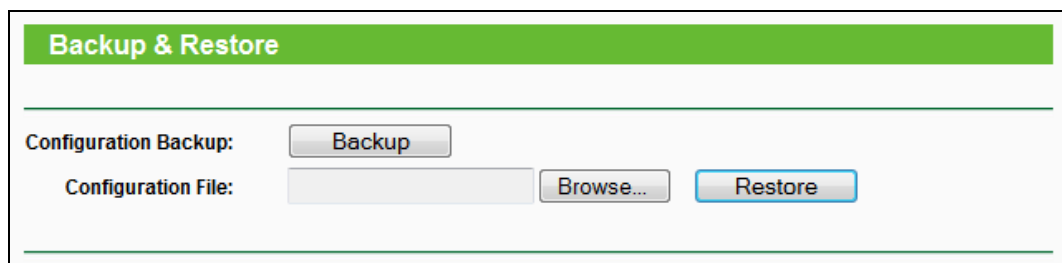

Figure 7-34 Backup & Restore Configuration

- Click the **Backup** button to save all configuration settings as a backup file in your local computer.
- To upgrade the Router's configuration, follow these instructions.
  - Click the **Browse...** button to locate the update file for the Router, or enter the exact path to the Setting file in the text box.
  - Click the **Restore** button.

**Note:**

The current configuration will be covered by the uploading configuration file. The upgrade process lasts for 20 seconds and the Router will restart automatically. Keep the Router on during the upgrading process to prevent any damage.

### 7.8.6 Reboot

Choose menu “**System Tools** → **Reboot**”, and then you can click the **Reboot** button to reboot the Router via the next screen.



Figure 7-35 Reboot the Router

Some settings of the Router will take effect only after rebooting, which include:

- Change the LAN IP Address (system will reboot automatically).
- Change the DHCP Settings.
- Change the Wireless configurations.
- Change the Web Management Port.
- Upgrade the firmware of the Router (system will reboot automatically).
- Restore the Router's settings to factory defaults (system will reboot automatically).
- Update the configuration with the file (system will reboot automatically).

### 7.8.7 Password

Choose menu “**System Tools** → **Password**”, and then you can change the factory default user name and password of the Router in the next screen as shown in Figure 7-36.

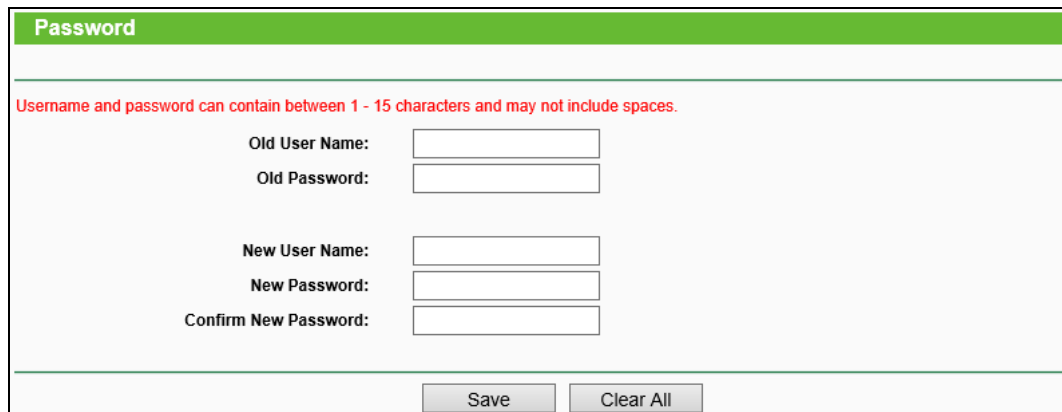

Figure 7-36 Password



It is strongly recommended that you should change the factory default user name and password of the Router, because all users who try to access the Router's Web-based utility or Quick Setup will be prompted for the Router's default user name and password.

 **Note:**

The new user name and password must not exceed 14 characters in length and not include any spaces. Enter the new Password twice to confirm.

Click the **Save** button when finished.

Click the **Clear All** button to clear all.

## 7.8.8 System Log

Choose menu “**System Tools** → **System Log**”, and then you can view the logs of the Router.

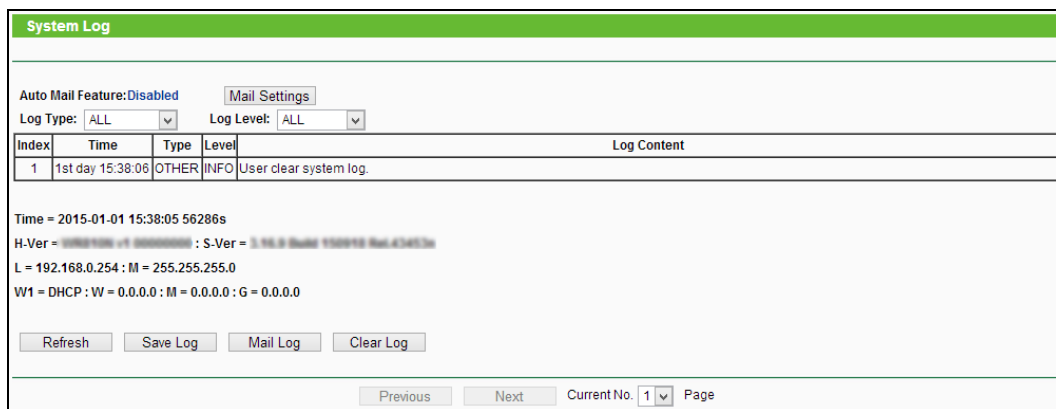

Figure 7-37 System Log

- **Refresh** - Refresh the page to show the latest log list.
- **Save Log** - Click to save all the logs in a txt file.
- **Mail Log** - Click to send an email of current logs manually according to the address and validation information set in Mail Settings. The result will be shown in the later log soon.
- **Clear Log** - All the logs will be deleted from this device permanently, not just from the page.

## Appendix A: FAQ

### 1. How do I configure the Router to access the Internet by ADSL users?

- 1) First, configure the ADSL Modem configured in RFC1483 bridge model.
- 2) Connect the Ethernet cable from your ADSL Modem to the WAN port on the Router. The telephone cord plugs into the Line port of the ADSL Modem.
- 3) Log in to the Router, click the **"Network"** menu on the left of your browser, and click **"WAN"** submenu. On the **WAN** page, select **"PPPoE/Russia PPPoE"** for WAN Connection Type. Type user name in the **"User Name"** field and password in the **"Password"** field and the **"Confirm Password"** field, and finish it by clicking **Connect**.

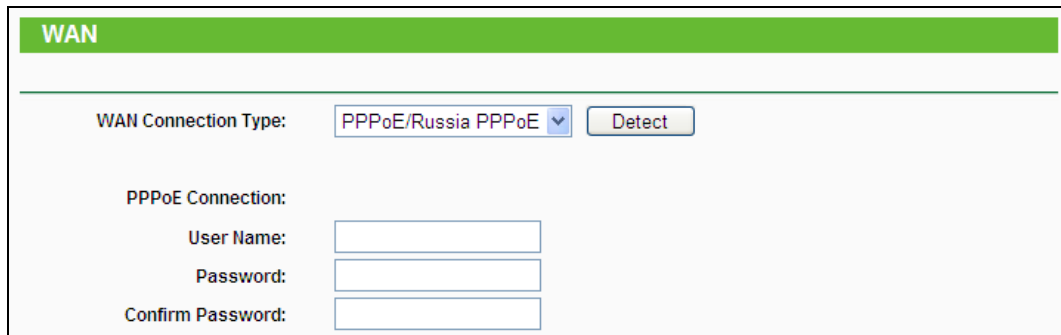

The screenshot shows the WAN configuration interface. At the top, there is a green header with the text "WAN". Below the header, the "WAN Connection Type" is set to "PPPoE/Russia PPPoE" with a dropdown arrow and a "Detect" button. Underneath, the "PPPoE Connection" section contains three input fields: "User Name:", "Password:", and "Confirm Password:".

Figure A-1 PPPoE Connection Type

- 4) If your ADSL lease is in "pay-according-time" mode, select **"Connect on Demand"** or **"Connect Manually"** for Internet connection mode. Type an appropriate number for **"Max Idle Time"** to avoid wasting paid time. Otherwise, you can select "Auto-connecting" for Internet connection mode.

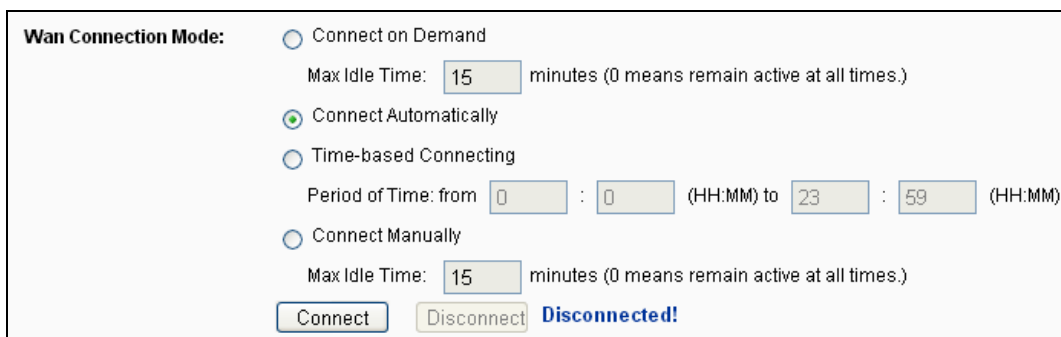

The screenshot shows the "Wan Connection Mode" configuration page. It features four radio button options: "Connect on Demand", "Connect Automatically" (which is selected), "Time-based Connecting", and "Connect Manually". Under "Connect on Demand", there is a "Max Idle Time" field set to "15" minutes. Under "Time-based Connecting", there is a "Period of Time" field set to "from 0 : 0 (HH:MM) to 23 : 59 (HH:MM)". Under "Connect Manually", there is another "Max Idle Time" field set to "15" minutes. At the bottom, there are "Connect" and "Disconnect" buttons, with the text "Disconnected!" displayed next to the "Disconnect" button.

Figure A-2 PPPoE Connection Mode

#### Note:

1. Sometimes the connection cannot be disconnected although you specify a time to Max Idle Time, since some applications is visiting the Internet continually in the background.
2. If you are a Cable user, please configure the Router following the above steps.

## 2. How do I configure the Router to access the Internet by Ethernet users?

- 1) Log in to the Router, click the **"Network"** menu on the left of your browser, and click **"WAN"** submenu. On the **WAN** page, select **"Dynamic IP"** for "WAN Connection Type", finish by clicking **Save**.
- 2) Some ISPs require that you register the MAC Address of your adapter, which is connected to your cable/DSL Modem during installation. If your ISP requires MAC register, log in to the Router and click the **"Network"** menu link on the left of your browser, and then click **"MAC Clone"** submenu link. On the **"MAC Clone"** page, if your PC's MAC address is proper MAC address, click the **Clone MAC Address** button and your PC's MAC address will fill in the "WAN MAC Address" field. Or else, type the MAC Address into the "WAN MAC Address" field. The format for the MAC Address is XX-XX-XX-XX-XX-XX. Then click the **Save** button. It will take effect after rebooting.

MAC Clone	
WAN MAC Address:	<input type="text" value="00-1D-0F-01-06-29"/> <input type="button" value="Restore Factory MAC"/>
Your PC's MAC Address:	<input type="text" value="6C-62-6D-F7-31-8D"/> <input type="button" value="Clone MAC Address"/>
<input type="button" value="Save"/>	

Figure A-3 MAC Clone

## 3. I want to use NetMeeting, what do I need to do?

- 1) If you start NetMeeting as a sponsor, you don't need to do anything with the Router.
- 2) If you start as a response, you need to configure Virtual Server or DMZ Host and make sure the H323 ALG is enabled.
- 3) How to configure Virtual Server: Log in to the Router, click the **"Forwarding"** menu on the left of your browser, and click **"Virtual Servers"** submenu. On the **"Virtual Servers"** page, click **Add New....** Then on the **"Add or Modify a Virtual Server Entry"** page, enter **"1720"** for the "Service Port" blank, and your IP address for the "IP Address" blank, taking 192.168.0.169 for an example, remember to **Enable** and **Save**.

Virtual Servers						
ID	Service Port	Internal Port	IP Address	Protocol	Status	Modify
1	1720	1720	192.168.0.169	All	Enabled	<a href="#">Modify</a> <a href="#">Delete</a>

Figure A-4 Virtual Servers

Add or Modify a Virtual Server Entry	
<b>Service Port:</b>	<input type="text"/> (00-00 or 000)
<b>Internal Port:</b>	<input type="text"/> (00, Only valid for single Service Port or leave it blank)
<b>IP Address:</b>	<input type="text"/>
<b>Protocol:</b>	All <input type="button" value="v"/>
<b>Status:</b>	Enabled <input type="button" value="v"/>
<b>Common Service Port:</b>	--Select One-- <input type="button" value="v"/>

Figure A-5 Add or Modify a Virtual server Entry

 **Note:**

Your opposite side should call your WAN IP, which is displayed on the “Status” page.

- How to enable DMZ Host: Log in to the Router, click the “**Forwarding**” menu on the left of your browser, and click “**DMZ**” submenu. On the “DMZ” page, click **Enable** radio button and type your IP address into the “DMZ Host IP Address” field, using 192.168.0.169 as an example, remember to click the **Save** button.

DMZ	
<b>Current DMZ Status:</b>	<input checked="" type="radio"/> Enable <input type="radio"/> Disable
<b>DMZ Host IP Address:</b>	<input type="text" value="192.168.0.169"/>

Figure A-6 DMZ

#### 4. I want to build a WEB Server on the LAN, what should I do?

- Because the WEB Server port 80 will interfere with the WEB management port 80 on the Router, you must change the WEB management port number to avoid interference.

- 2) To change the WEB management port number: Log in to the Router, click the “**Security**” menu on the left of your browser, and click “**Remote Management**” submenu. On the “**Remote Management**” page, type a port number except 80, such as 88, into the “Web Management Port” field. Click **Save** and reboot the Router.

Figure A-7 Remote Management

**Note:**

If the above configuration takes effect, configure to the Router by typing 192.168.0.188 (the Router’s LAN IP address: Web Management Port) in the address field of the Web browser.

- 3) Log in to the Router, click the “**Forwarding**” menu on the left of your browser, and click the “**Virtual Servers**” submenu. On the “**Virtual Servers**” page, click **Add New...**, then on the “**Add or Modify a Virtual Server**” page, enter “88” into the blank next to the “**Service Port**”, and your IP address next to the “**IP Address**”, assuming 192.168.0.188 for an example, remember to **Enable** and **Save**.

ID	Service Port	Internal Port	IP Address	Protocol	Status	Modify
1	88	88	192.168.0.188	All	Enabled	<a href="#">Modify</a> <a href="#">Delete</a>

Figure A-8 Virtual Servers

Figure A-9 Add or Modify a Virtual server Entry

**5. The wireless stations cannot connect to the Router.**

- 1) Make sure the "**Enable Wireless Router Radio**" is checked.
- 2) Make sure that the wireless stations' SSID accord with the Router's SSID.
- 3) Make sure the wireless stations have right KEY for encryption when the Router is encrypted.
- 4) If the wireless connection is ready, but you can't access the Router, check the IP Address of your wireless stations.

## Appendix B: Configuring the PC

In this section, we'll introduce how to install and configure the TCP/IP correctly in Windows 7. First make sure your Ethernet Adapter is working, refer to the adapter's manual if needed.

### 1. Install TCP/IP component

- 1) On the Windows taskbar, click the **Start** button, and then click **Control Panel**.
- 2) Click the **Network and Internet**, and click the **Network and Sharing Center**, then click **Change adapter settings**.
- 3) Right click the icon that showed below, select **Properties** on the prompt page.

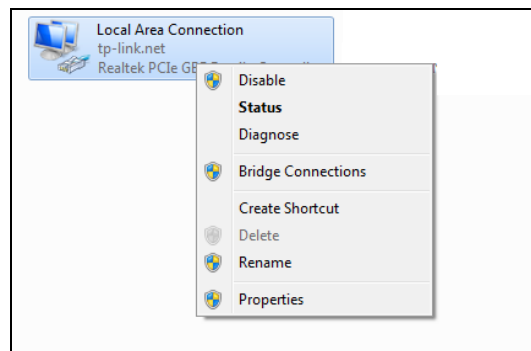

Figure B-0-1

- 4) In the prompt page that showed below, double click on the **Internet Protocol Version 4 (TCP/IPv4)**.

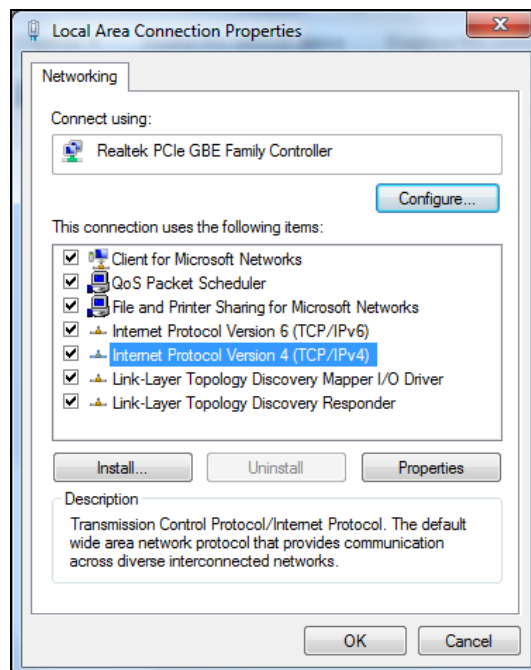

Figure B-0-2

- 5) The following **TCP/IP Properties** window will display and the **IP Address** tab is open on this window by default.

Now you have two ways to configure the **TCP/IP** protocol below:

➤ **Setting IP address automatically**

Select **Obtain an IP address automatically**, Choose **Obtain DNS server automatically**, as shown in the Figure below:

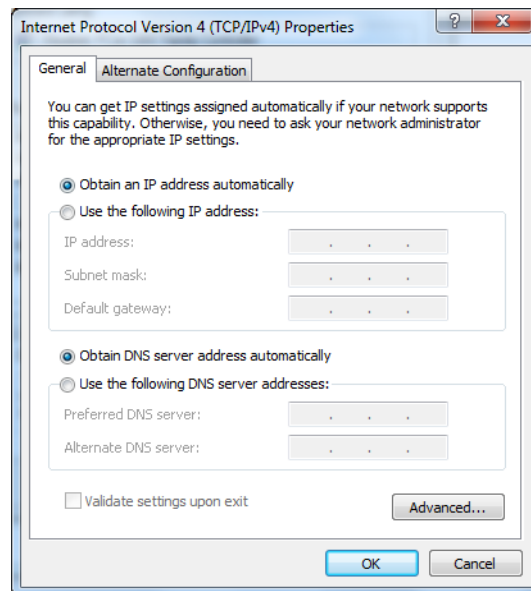

Figure B-0-3

➤ **Setting IP address manually**

- 1 Select **Use the following IP address** radio button. And the following items available
- 2 If the router's LAN IP address is 192.168.0.1, specify the IP address as 192.168.0.x (x is from 2 to 254), and **Subnet mask** is 255.255.255.0.
- 3 Type the router's LAN IP address (the default IP is 192.168.0.1) into the **Default gateway** field.
- 4 Select **Use the following DNS server addresses** radio button. In the **Preferred DNS Server** field you can type the DNS server IP address, which has been provided by your ISP



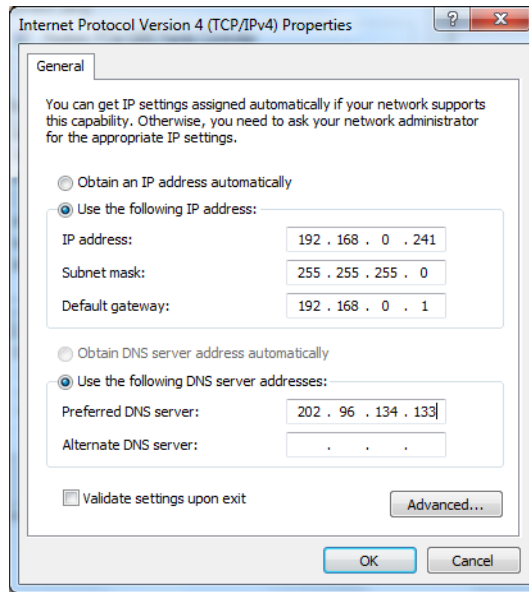

Figure B-0-4

## Appendix C: Specifications

General	
Standards	IEEE 802.11n, 802.11b, 802.11g
Protocols	TCP/IP, PPPoE, DHCP, ICMP, NAT, SNTP
Port	One 10/100Mbps LAN/WAN port One 10/100Mbps LAN port
Cabling Type	10BASE-T: UTP category 3, 4, 5 cable (maximum 100m) EIA/TIA-568 100Ω STP (maximum 100m)
	100BASE-TX: UTP category 5, 5e cable (maximum 100m) EIA/TIA-568 100Ω STP (maximum 100m)
LED	SYS
Dimensions (LxWxH)	85mm x 75mm x 28mm
Safety & Emissions	FCC, CE
Wireless	
Frequency Band	2.4~2.4835GHz
Radio Data Rate	11n: up to 300Mbps (Automatic) 11g: 54/48/36/24/18/12/9/6M (Automatic) 11b: 11/5.5/2/1M (Automatic)
Frequency Expansion	DSSS(Direct Sequence Spread Spectrum)
Modulation	DBPSK, DQPSK, CCK, 16-QAM, 64-QAM, BPSK, QPSK
Security	64/128/152-bit WEP, WPA/WPA2, WPA2-PSK/WPA-PSK
Sensitivity @PER	135M: -70dBm@10% PER 65M: -73dBm@10% PER 54M: -76dBm@10% PER 6M: -92dBm@10% PER
Mode	Standard Wireless Router Mode, Access Point Mode, Repeater Mode, Client Mode
Environmental and Physical	
Temperature	Operating : 0°C~40°C (32°F~104°F)
	Storage: -40°C~70°C(-40°F~158°F)
Humidity	Operating: 10% - 90% RH, Non-condensing
	Storage: 5% - 90% RH, Non-condensing

## Appendix D: Glossary

- **802.11n** - 802.11n builds upon previous 802.11 standards by adding MIMO (multiple-input multiple-output). MIMO uses multiple transmitter and receiver antennas to allow for increased data throughput via spatial multiplexing and increased range by exploiting the spatial diversity, perhaps through coding schemes like Alamouti coding. The Enhanced Wireless Consortium (EWC) [3] was formed to help accelerate the IEEE 802.11n development process and promote a technology specification for interoperability of next-generation wireless local area networking (WLAN) products.
- **802.11b** - The 802.11b standard specifies a wireless networking at 11 Mbps using direct-sequence spread-spectrum (DSSS) technology and operating in the unlicensed radio spectrum at 2.4GHz, and WEP encryption for security. 802.11b networks are also referred to as Wi-Fi networks.
- **802.11g** - specification for wireless networking at 54 Mbps using direct-sequence spread-spectrum (DSSS) technology, using OFDM modulation and operating in the unlicensed radio spectrum at 2.4GHz, and backward compatibility with IEEE 802.11b devices, and WEP encryption for security.
- **DDNS (Dynamic Domain Name System)** - The capability of assigning a fixed host and domain name to a dynamic Internet IP Address.
- **DHCP (Dynamic Host Configuration Protocol)** - A protocol that automatically configure the TCP/IP parameters for the all the PC(s) that are connected to a DHCP server.
- **DMZ (Demilitarized Zone)** - A Demilitarized Zone allows one local host to be exposed to the Internet for a special-purpose service such as Internet gaming or videoconferencing.
- **DNS (Domain Name System)** - An Internet Service that translates the names of websites into IP addresses.
- **Domain Name** - A descriptive name for an address or group of addresses on the Internet.
- **DSL (Digital Subscriber Line)** - A technology that allows data to be sent or received over existing traditional phone lines.
- **ISP (Internet Service Provider)** - A company that provides access to the Internet.
- **MTU (Maximum Transmission Unit)** - The size in bytes of the largest packet that can be transmitted.
- **NAT (Network Address Translation)** - NAT technology translates IP addresses of a local area network to a different IP address for the Internet.

- **PPPoE (Point to Point Protocol over Ethernet)** - PPPoE is a protocol for connecting remote hosts to the Internet over an always-on connection by simulating a dial-up connection.
- **SSID - A Service Set Identification** is a thirty-two character (maximum) alphanumeric key identifying a wireless local area network. For the wireless devices in a network to communicate with each other, all devices must be configured with the same SSID. This is typically the configuration parameter for a wireless PC card. It corresponds to the ESSID in the wireless Access Point and to the wireless network name.
- **WEP (Wired Equivalent Privacy)** - A data privacy mechanism based on a 64-bit or 128-bit or 152-bit shared key algorithm, as described in the IEEE 802.11 standard.
- **Wi-Fi** - A trade name for the 802.11b wireless networking standard, given by the Wireless Ethernet Compatibility Alliance (WECA, see <http://www.wi-fi.net>), an industry standards group promoting interoperability among 802.11b devices.
- **WLAN (Wireless Local Area Network)** - A group of computers and associated devices communicate with each other wirelessly, which network serving users are limited in a local area.