

Quick Installation Guide

54Mbps Wireless Router

MODEL NO. TL-WR340G/TL-WR340GD

Package Contents

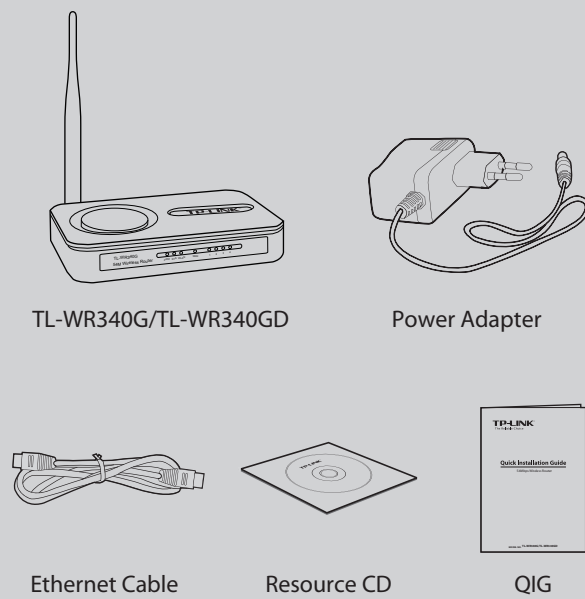

System Requirement

· Windows 7 · Windows Vista · Windows XP · Windows 2000

1 Hardware Connection

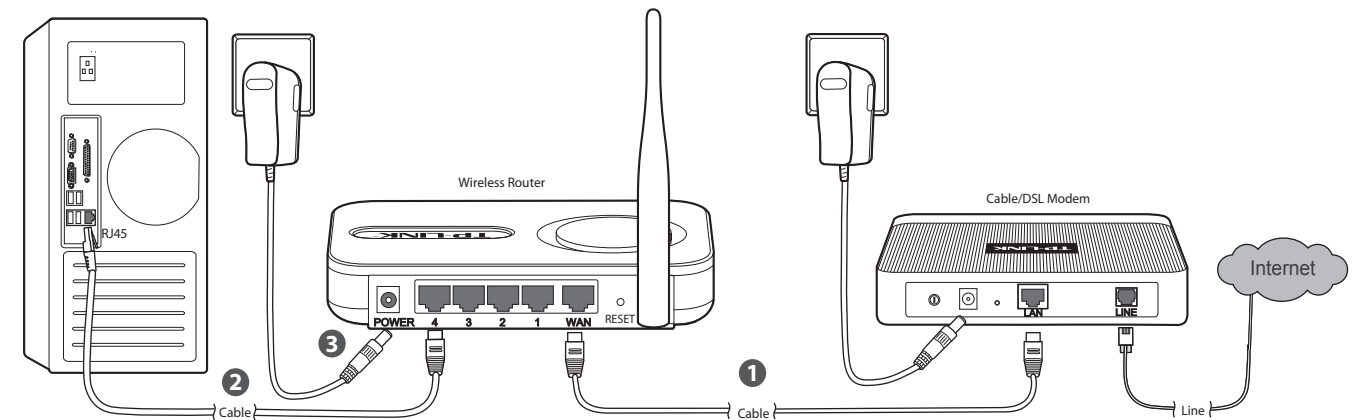

- Step 1. Connect the WAN port on your Router to the Modem's LAN port with an Ethernet cable.
- Step 2. Connect your computer to any Port labeled 1~4 on the Router with an Ethernet cable.
- Step 3. Plug the provided Power Adapter into the Power jack on the back of the Router and the other end to a standard electrical Wall socket, and power on the Modem.

2 Connecting by Easy Setup Assistant



The Easy Setup Assistant is not supported in Linux or Mac OS. If you are running Linux /Mac or without CD-ROM, please refer to **Appendix 1**.

- 1 Insert the TP-LINK Resource CD into the CD-ROM drive.

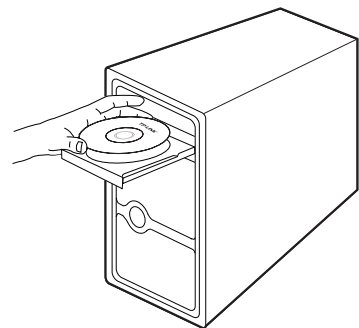

- 2 Here we take TL-WR340G for example. Select **TL-WR340G** and click **Easy Setup Assistant**.



- 3 After confirming the hardware connection and the status of LEDs, click **Next** to continue.

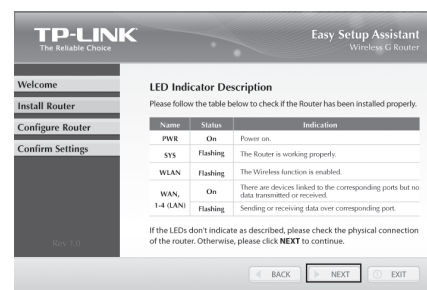

- 4 After the connectivity has been checked successfully, please click **Next** to continue.

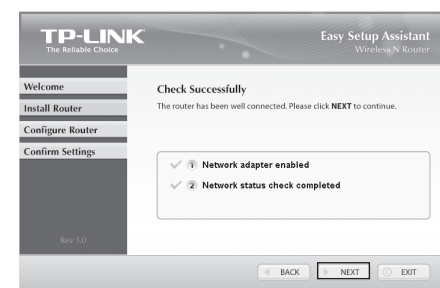

- 5 Select the connection type your ISP provides and click **Next**. Here we take connection type **PPPoE** for example.

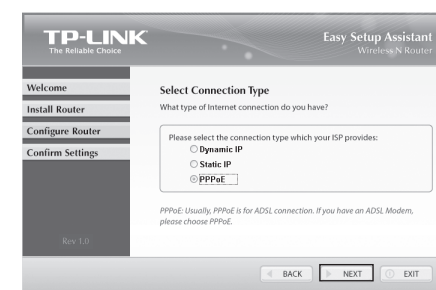

- 6 Enter the **User Name** and **Password** provided by your ISP and then click **Next**.

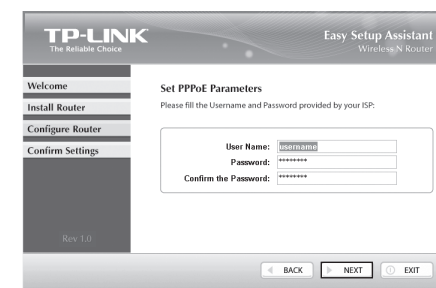

- 7 Create a unique or easy-to-remember name for your wireless network. You can also keep the default setting. Click **Next** to continue.

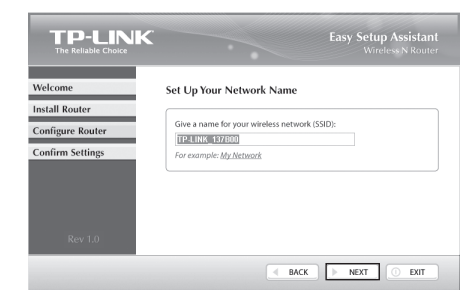

- 8 You are recommended to select **Most Security (WPA2-PSK)** to secure your wireless network. Enter a key of 8~63 characters and click **Next**.



(Turn over)

2 Connecting by Easy Setup Assistant (continued)

- 9 After confirming the configuration, click **NEXT** to continue.

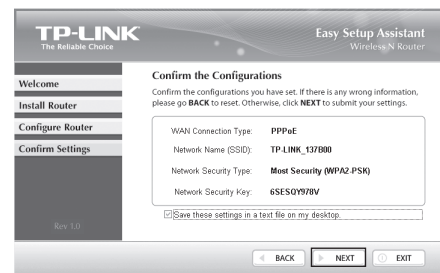

Note You can save these settings in a text file on your desktop. If you forget the Network Security Key, you can check the **Router Settings.txt**.

- 10 After the configuration is completed successfully, please click **Next**.



- 11 Click **FINISH** to close the wizard.

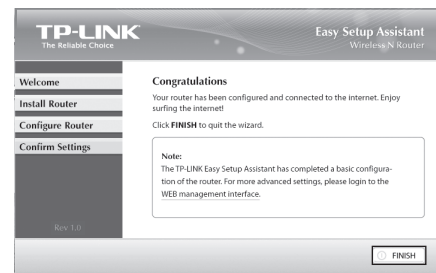

Note You can click **WEB management interface** for more advanced settings.

- 12 The basic settings for your Router are completed. You can go to <http://www.tp-link.com> to verify the Internet connection.

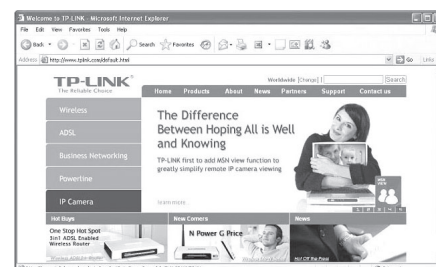

Appendix 1: Connecting by WEB Management Interface

You can go to WEB management interface to configure your Router.

- 1) Set the IP address of your wired network adapter as **Automatically**.

For Windows 7

Go to '**Start > Control Panel**'. Click '**View network status and tasks > Local Area Connection > Properties**' and double-click '**Internet Protocol Version 4 (TCP/IPv4)**'. Select '**Obtain an IP address automatically**', choose '**Obtain DNS server address automatically**' and click '**OK**'.

For Windows Vista

Go to '**Start > Settings > Control Panel**'. Click '**View network status and tasks > View status > Properties**' and double-click '**Internet Protocol Version 4 (TCP/IPv4)**'. Select '**Obtain an IP address automatically**', choose '**Obtain DNS server address automatically**' and click '**OK**'.

For Windows XP/2000

Go to '**Start > Control Panel**'. Click '**Network and Internet Connections > Network Connections**'. Right-click '**Local Area Connection**', select '**Properties**' and then double-click '**Internet Protocol (TCP/IP)**'. Select '**Obtain an IP address automatically**', choose '**Obtain DNS server address automatically**' and click '**OK**'.

- 2) Open your browser and type **tplinklogin.net** in the address field. Then use **admin** for user name and password to login.
- 3) Go to **Quick Setup** and click **Next**. Select your Internet connection type and click **Next**.

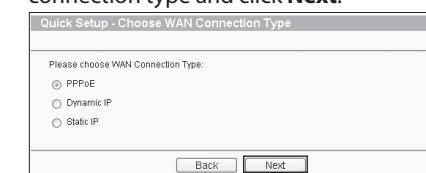

- 4) Here we take **PPPoE** for example. Enter the **User Name** and **Password** provided by your ISP and then click **Next**.

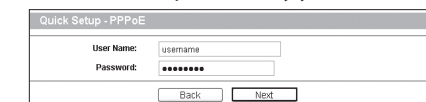

- 5) Configure your network name (SSID) and password, and then click **Next** to continue.

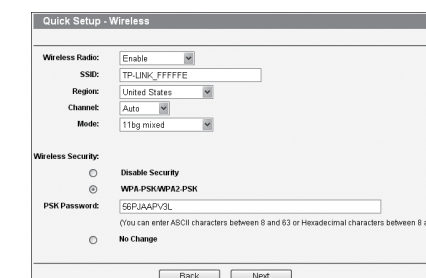

- 6) Click **Finish** or **Reboot** to make your settings take effect.

Appendix 2: Troubleshooting

How do I restore my Router's configuration to its factory default settings?

With the Router powered on, press and hold the **RESET** button on the rear panel for 8 to 10 seconds using a pin before releasing it.

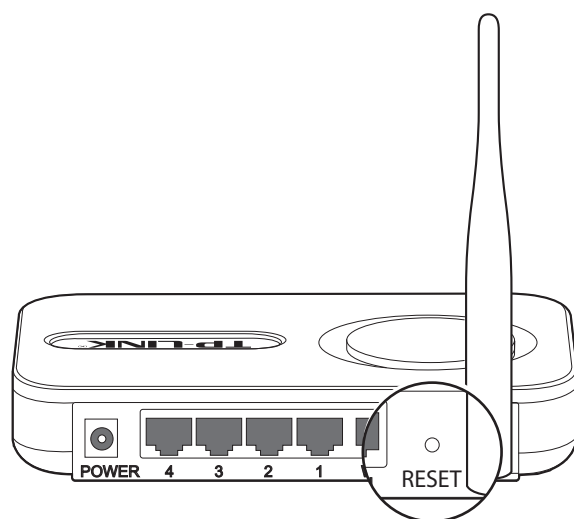

What can I do if I cannot access the Internet?

- 1) Check to see if all the connectors are connected well, including the telephone line (for your modem), Ethernet cables and power adapter.
- 2) Check to see if you can access the Router's web management page. If you can, please follow the following steps to solve the problem. If you can't, please refer to **Appendix 1**.
- 3) Make sure that you are connected to the TP-LINK Router with the computer that was originally connected to your modem, then log on to the web-based management page and browse to '**Network > MAC Clone**', click '**Clone MAC address**' and then click '**Save**'. Reboot the Router and try to access the Internet from your computer, if the problem persists, please go to the next step.

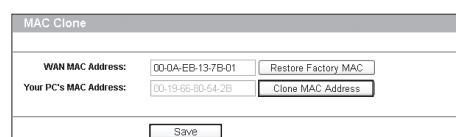

- 4) Please feel free to contact our Technical Support if the problem persists.

What can I do if I forgot my password?

- 1) Restore the Router's configuration to its factory default settings. If you don't know how to do that, please refer to **How do I restore my Router's configuration to its factory default settings?**
- 2) Use the default user name and password: admin, admin.
- 3) Try to configure your router once again by following the instructions in the previous steps of the QIG.



You can refer to our User Guide on the CD to set up more functions of the Router.

Technical Support

- For more troubleshooting help, go to www.tp-link.com/support/faq.asp
- To download the latest Firmware, Driver, Utility and User Guide, go to www.tp-link.com/support/download.asp
- For all other technical support, please contact us by using the following details:

Global

Tel: +86 755 26504400
E-mail: support@tp-link.com

Singapore

Tel: +65 62840493
E-mail: support.sg@tp-link.com
Service time: 24hrs, 7days a week

UK

Tel: +44 (0) 845 147 0017
E-mail: support.uk@tp-link.com
Service time: 24hrs, 7days a week

USA/Canada

Toll Free: +1 866 225 8139
E-mail: support.usa@tp-link.com
Service time: 24hrs, 7days a week

Germany / Austria

Tel: +49 1805 875465 (German Service) / +49 1805 TPLINK
E-mail: support.de@tp-link.com
Fee: 0.14 EUR/min from the German fixed phone network and up to 0.42 EUR/min from mobile phone.
Service Time: Monday to Friday 9:00 AM to 6:00 PM. GMT+1 or GMT+2 (Daylight Saving Time in Germany)
* Except bank holidays in Hesse

Australia & New Zealand

Tel: AU 1300 87 5465
NZ 0800 87 5465
E-mail: support@tp-link.com.au
Service time: 24hrs, 7 days a week

Malaysia

Tel: 1300 88 875465 (1300 88TPLINK)
E-mail: support.my@tp-link.com
Service time: 24 hrs a day, 7days a week

Turkey

Tel: 444 19 25 (Turkish Service)
E-mail: support.tr@tp-link.com
Service time: 9:00 AM to 6:00 PM, 7days a week

Italy

Tel: +39 02 66987799
E-mail: support.it@tp-link.com
Service time: 9:00 AM to 6:00 PM, from Monday to Friday

Switzerland

Tel: +41 (0)848 800998
(German service)
E-mail: support.ch@tp-link.com
Fee: 4-8 Rp/min, depending on rate of different time
Service time: Monday to Friday 9:00 AM to 6:00 PM. GMT+1 or GMT+2 (Daylight Saving Time)