

Quick Installation Guide

AV500 Powerline Adapter

MODEL NO. TL-PA411

1 LED and Button Descriptions

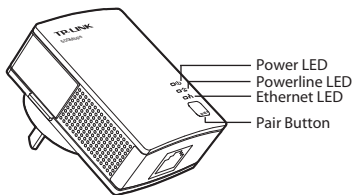

Item	Status	Description
Power LED	Solid	The adapter is on.
	Blinking	The adapter is in power-saving mode or in pairing procedure.
	Off	The adapter is off.
Powerline LED	Solid	The adapter is connected to a powerline network.
	Blinking	The adapter is transferring data.
	Off	The adapter isn't connected to any powerline network or is in power-saving mode.*
Ethernet LED	Solid	The Ethernet port is connected, but there is no data being transferred.
	Blinking	The Ethernet port is transferring data.
	Off	The Ethernet port isn't connected.

* Five minutes after the device connected to the adapter is turned off, the adapter will automatically switch to power-saving mode.

Item	Description
Pair Button	Pair button is used to secure a powerline network. To secure your network, please refer to Appendix: Using the Pair Button .

Package Contents



Powerline Adapter



QIG

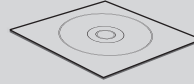

Resource CD
(For Windows Only)

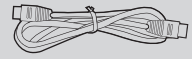

Ethernet Cable

Warning on Final Location

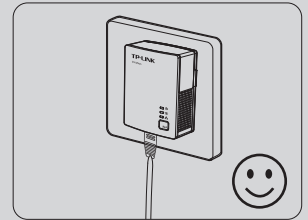
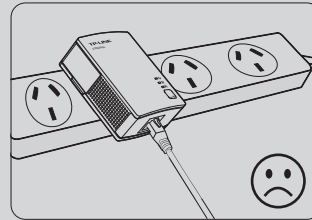

NOTE: It's strongly recommended that you plug the adapter directly into the wall socket, for some power strips have surge protector which can filter data.

71106504738 REV1.0.0

2 Network Installation

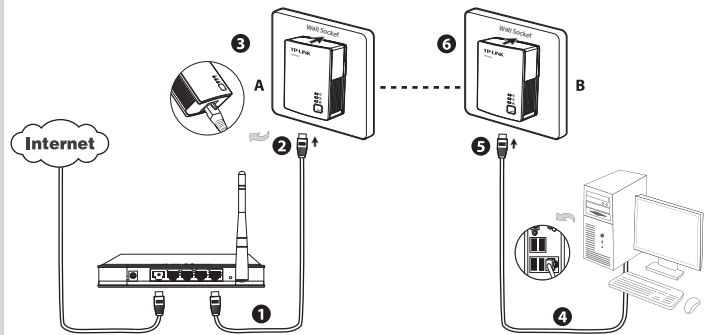

TP-LINK powerline adapters are Plug and Play. After taking the steps above, you can surf the Internet.

To add another adapter

Plug an additional adapter into the wall socket, and the connection will be established automatically within 60 seconds.

NOTE:

- To surf the Internet, please make sure that your router is properly connected to the Internet.
- If the adapters fail to automatically link to each other, you can establish a private network by using the pair button. To set up a private network, please go to **Appendix: Using the Pair Button** for detailed instructions.

Appendix: Using the Pair Button (Setting up a private network)

To set up a private network:

1. Press the pair button on adapter A for 1 second and the Power LED will begin flashing. If pressed till all the LEDs turn off (about 10 seconds), the adapter will leave the network.
2. Within 2 minutes, press the pair button on adapter B for 1 second and the Power LED will begin flashing as well.
3. In about 60 seconds you'll see the Powerline LEDs on both adapters light up, indicating the two adapters have intercommunicated with each other successfully.

* It is highly recommended to first set up the two adapters in the same room or on the same power strip and then place them in a suitable location.

To join an existing private network:

If you want to add adapter C to the existing private network, please follow the steps.

1. Press the pair button on the adapter A or B for 1 second (do not press both), and the Power LED will begin flashing.
2. Within 2 minutes press the pair button on adapter C for 1 second, the Powerline LED on the adapter C will light up in about 60 seconds.

* You can follow the steps above to add more adapters to the private network one by one.

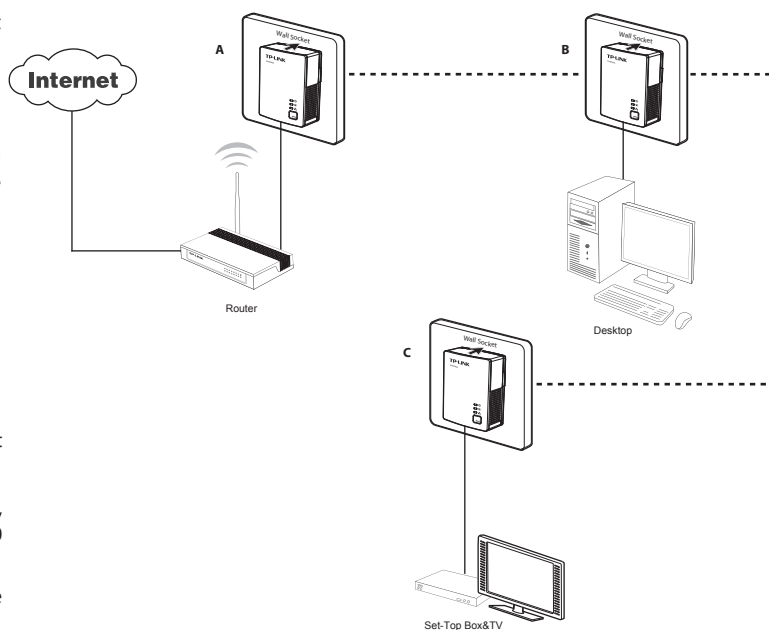

NOTE:

More advanced configuration, such as reset, firmware upgrade and QoS configuration can be accessed through the utility, so install the Powerline Utility if necessary. You can obtain the Powerline Utility from the Resource CD (for Windows only) or TP-LINK official website (for Windows and Mac OS X). For detailed instructions, please refer to the User Guide on the Resource CD or TP-LINK official website.

Troubleshooting

Q1. I have followed the above instructions, but my adapters are still not working. What can I do?

1. Make sure all the adapters are under the same electric meter.
2. If the Power LED does not light up at all, there may be a hardware problem.
3. The PLC devices might not communicate with each other if they are in different phases of a four-wire three-phase circuit.
4. As some power strips have surge protector, please make sure the adapters are not separated by the power strips.

Q2. The adapters were working fine but no longer work now that they've been moved. How do I make them work again?

Plug the adapters into the same power strip and follow **Appendix: Using the Pair Button** to pair them. If they still don't work, please check for possible interference causes:

1. Air-conditioners, washing machines, and other similar household appliances are working too close to the adapters.
2. Air switch may lead to failed communication among PLC devices; check whether there are air switches hindering communication.

Technical Support

- For more troubleshooting help, go to: <http://www.tp-link.com/en/support/faq>
- To download the latest Firmware, Driver, Utility and User Guide, go to: <http://www.tp-link.com/en/support/download>
- For all other technical support, please contact us by using the following details:

Global

Tel: +86 755 2650 4400
Fee: Depending on rate of different carriers, IDD.
E-mail: support@tp-link.com
Service time: 24hrs, 7 days a week

UK

Tel: +44 (0) 845 147 0017
Fee: Landline: 1p-10.5p/min, depending on the time of day. Mobile: 15p-40p/min, depending on your mobile network.
E-mail: support.uk@tp-link.com
Service time: 24hrs, 7 days a week

Turkey

Tel: 0850 7244 488 (Turkish Service)
Fee: Depending on rate of different carriers.
E-mail: support.tr@tp-link.com
Service time: 09:00 to 21:00
7 days a week

Ukraine

Tel: 0800 505 508
Fee: Free for Landline; Mobile: Depending on rate of different carriers
E-mail: support.ua@tp-link.com
Service time: Monday to Friday
10:00 to 22:00

Brazil

Toll Free: 0800 608 9799 (Portuguese Service)
E-mail: support.br@tp-link.com
Service time: Monday to Friday, 09:00 to 20:00;
Saturday, 09:00 to 15:00

France

Tel: 0820 800 860 (French service)
Fee: 0.118 EUR/min from France
Email: support.fr@tp-link.com
Service time: Monday to Friday, 09:00 to 18:00
*Except French Bank holidays

Russian Federation

Tel: 8 (499) 754 5560 (Moscow NO.)
8 (800) 250 5560 (Toll-free within RF)
E-mail: support.ru@tp-link.com
Service time: From 09:00 to 21:00 (Moscow time)
*Except weekends and holidays in RF

Switzerland

Tel: +41 (0) 848 800 998 (German Service)
Fee: 4-8 Rp/min, depending on rate of different time.
E-mail: support.ch@tp-link.com
Service time: Monday to Friday, 09:00 to 12:30
and 13:30 to 17:30. GMT+1 or GMT+2 (DST)

Singapore

Tel: +65 6284 0493
Fee: Depending on rate of different carriers.
E-mail: support.sg@tp-link.com
Service time: 24hrs, 7 days a week

USA/Canada

Toll Free: +1 866 225 8139
E-mail: support.usa@tp-link.com
Service time: 24hrs, 7 days a week

Australia/New Zealand

Tel: NZ 0800 87 5465 (Toll Free)
AU 1300 87 5465 (Depending on 1300 policy.)
E-mail: support.au@tp-link.com (Australia)
support.nz@tp-link.com (New Zealand)
Service time: 24hrs, 7 days a week

Italy

Tel: +39 023 051 9020
Fee: Depending on rate of different carriers.
E-mail: support.it@tp-link.com
Service time: Monday to Friday
09:00 to 13:00; 14:00 to 18:00

Indonesia

Tel: (+62) 021 6386 1936
Fee: Depending on rate of different carriers.
E-mail: support.id@tp-link.com
Service time: Monday to Friday 09:00 to 18:00
*Except public holidays

Malaysia

Toll Free: 1300 88 875 465
Email: support.my@tp-link.com
Service time: 24hrs, 7 days a week

Poland

Tel: +48 (0) 801 080 618 / +48 223 606 363 (if calls from mobile phone)
Fee: Depending on rate of different carriers.
E-mail: support.pl@tp-link.com
Service time: Monday to Friday, 09:00 to 17:00.
GMT+1 or GMT+2 (DST)

Germany/Austria

Tel: +49 1805 875 465 (German Service)
+49 1805 TPLINK
+43 820 820 360
Fee: Landline from Germany: 0.14EUR/min.
Landline from Austria: 0.20EUR/min.
E-mail: support.de@tp-link.com
Service time: Monday to Friday, 09:00 to 12:30
and 13:30 to 17:30. GMT+1 or GMT+2 (DST in Germany)
*Except bank holidays in Hesse