

## Quick Installation Guide

150Mbps Wireless N USB Adapter

MODEL NO. TL-WN727N

### Package Contents

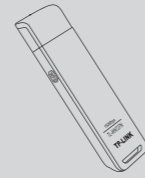

TL-WN727N



QIG



USB Cable

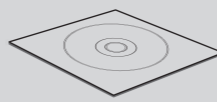

Resource CD

### System Requirement

· Windows 8 · Windows 7 · Windows Vista · Windows XP

## 1 Hardware Connection

Method One

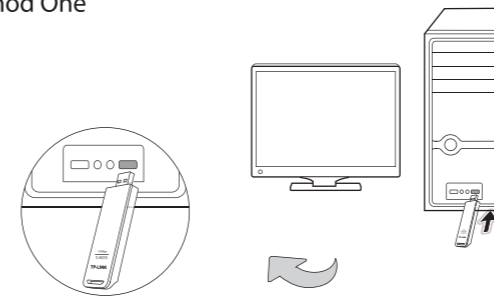

Method Two

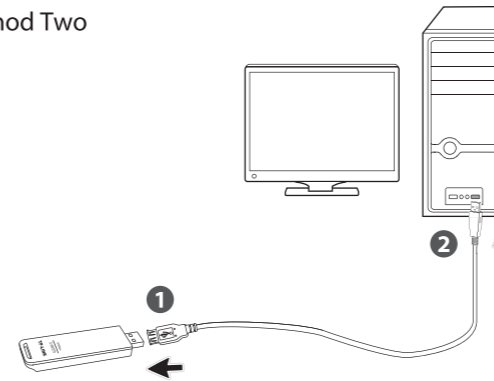

You may see the **Found New Hardware Wizard** (Found New Hardware), when the adapter is plugged. Please click **Cancel**.

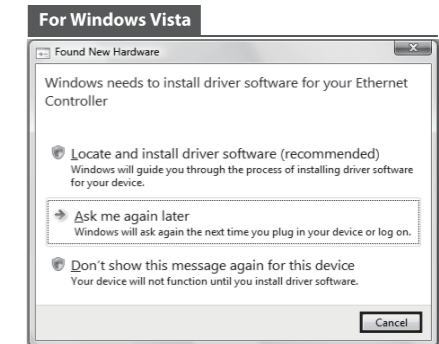

## 2 Software Installation

(The installation procedures in Windows 8/7/Vista/XP are similar. Here takes the procedures in Windows 7 for example.)

**1** Insert the TP-LINK resource CD into the CD-ROM drive.

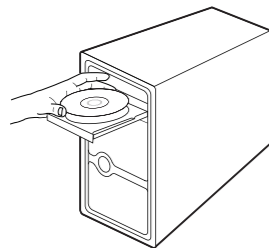

**2** Find the model TL-WN727N and select **Install Driver&Utility**.



**3** The **InstallShield Wizard** window will appear. Click **Next** to continue.

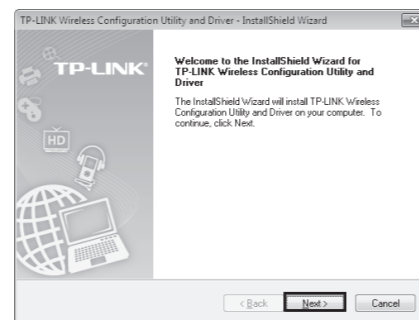

**4** Select **Install TP-LINK Wireless Configuration Utility and Driver** and then click **Next**.

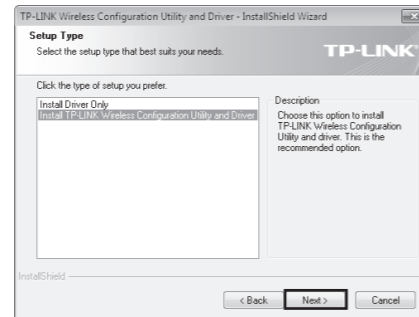

**5** Click **Change** to specify the destination location or you can leave it default. Click **Next** to continue.

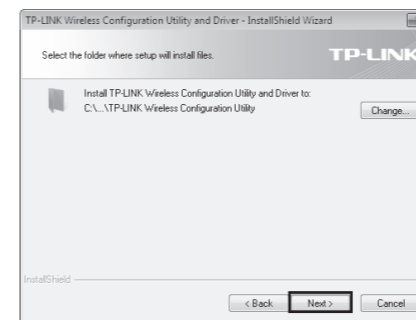

**6** Click **Install** to install the driver and utility for your adapter.

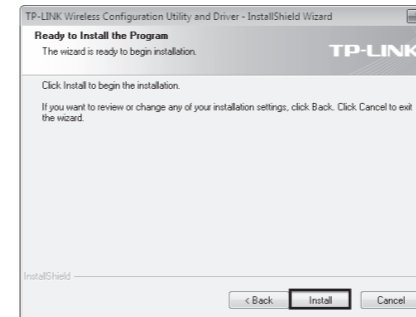

**7** The installation of the driver and utility may take 1~2 minutes.

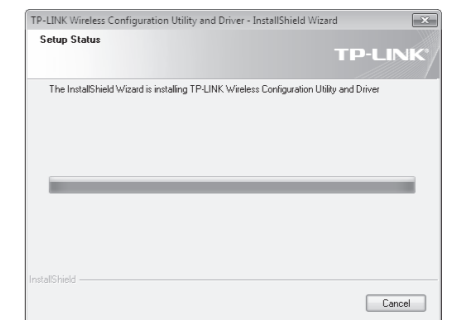

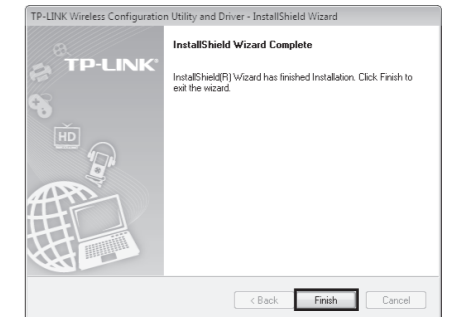

**8** The following screen will then appear. Click **Finish** to complete the setup.

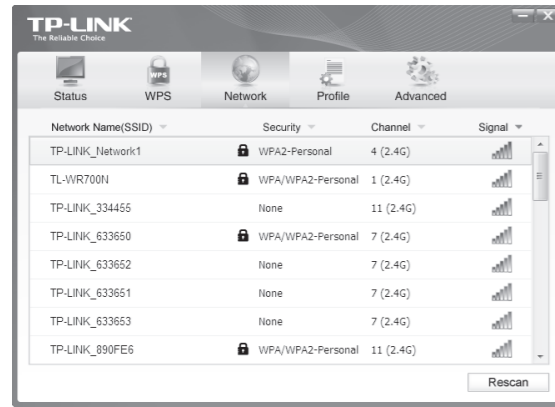

# 3 Connect to Network (You can skip to **Appendix: Connect to Wireless Router by WPS** to quickly connect to a network if your Router or Access Point features WPS/QSS function.)

**1** After installation, the configuration page will pop up on your desktop.



**Note** The icon  will appear on your desktop. Double-clicking on the icon can start the utility.

**2** Click **Network** in the tools section to display a list of available wireless networks. Highlight the target network name (e.g. TP-LINK\_Network1) and then click **Connect** to build a connection.

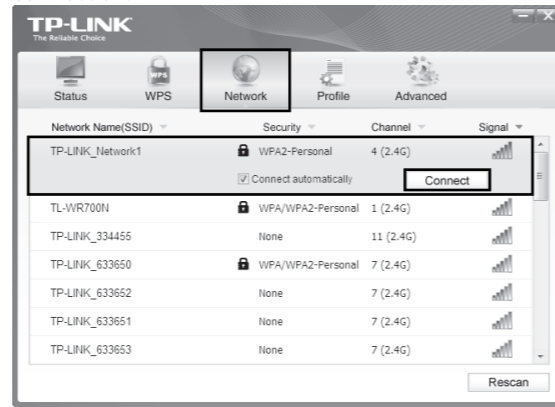

**Note** Here we only choose a wireless network with the security type of **WPA/WPA2-Personal** as an example to elaborate the following steps. If you want to know more about the connection to a wireless network with the security type of **WPA/WPA2-Enterprise**, please refer to the User Guide on the resource CD included.

**3** If the network is unsecured, you will directly connect to it. If it is security-enabled, you can input the security key into the field beside **Security Key** and then click **OK** to continue.



**Note** Without entering a key, you can press the WPS button on your router if the prompt **You can also connect by pushing the button on the router** appears.

**4** The following screen indicates successful connectivity. Click **Close** to enjoy the Internet.

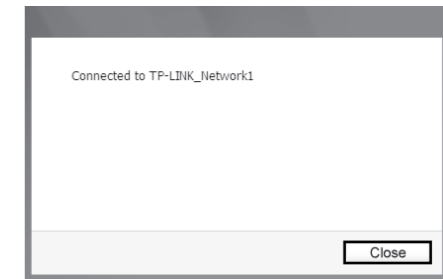

**5** To view more information about the network connected, click **Status** in the tools section.

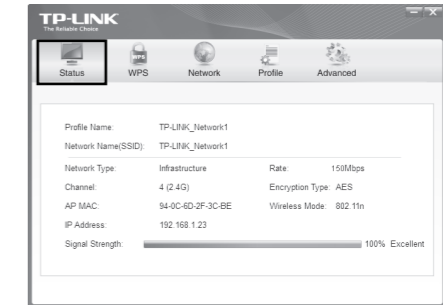

## Appendix: Connect to Wireless Router by WPS

If your wireless Router features the WPS/QSS function, you can also set up a wireless connection in this way.

**1** Push the **WPS/RESET** button on the back panel of the Router. Here we take Router TL-WR841ND for example.



**2** With the adapter plugged into the USB port on your computer, push the **WPS** button on the adapter.

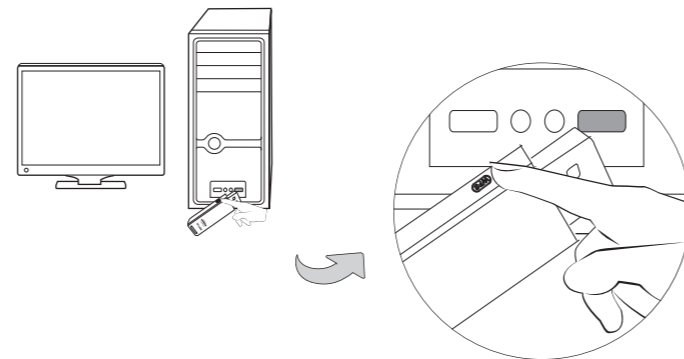

**Note** For detailed instructions of WPS, please refer to the User Guide on the resource CD.

**3** Wait a while for the connection progress to be completed. The following screen indicates that the connection has been successfully built. Click **OK** to finish the WPS connection.



### Technical Support

- For more troubleshooting help, go to [www.tp-link.com/en/support/faq](http://www.tp-link.com/en/support/faq)
  - To download the latest Firmware, Driver, Utility and User Guide, go to <http://www.tp-link.com/en/support/download/>
  - For all other technical support, please contact us by using the following details:
- |   |  |
|---|--|
| <p><b>Global</b><br/>Tel: +86 755 2650 4400<br/>E-mail: support@tp-link.com<br/>Service time: 24hrs, 7 days a week</p> <p><b>Singapore</b><br/>Tel: +65 6284 0493<br/>E-mail: support.sg@tp-link.com<br/>Service time: 24hrs, 7 days a week</p> <p><b>UK</b><br/>Tel: +44 (0) 845 147 0017<br/>E-mail: support.uk@tp-link.com<br/>Service time: 24hrs, 7days a week</p> <p><b>Ukraine</b><br/>Tel: 0800 505 508<br/>E-mail: support.ua@tp-link.com<br/>Service time: Monday to Friday 10:00 to 22:00</p> <p><b>Brazil</b><br/>Toll Free: 0800 608 9799<br/>(Portuguese Service)<br/>E-mail: suporte.br@tp-link.com<br/>Service time: Monday to Friday, 09:00 to 20:00; Saturday, 09:00 to 15:00</p> <p><b>Italy</b><br/>Tel: +39 023 051 9020<br/>E-mail: support.it@tp-link.com<br/>Service time: Monday to Friday, 09:00 to 13:00; 14:00 to 18:00</p> <p><b>Indonesia</b><br/>Tel: (+62) 021 6386 1936<br/>E-mail: support.id@tp-link.com<br/>Service time: Monday to Friday, 09:00 to 18:00<br/>* Except public holidays</p> <p><b>Germany / Austria</b><br/>Tel: +49 1805 875 465 (German Service)<br/>+49 1805 TPLINK +43 820 820 360<br/>E-mail: support.de@tp-link.com<br/>Fee: 0.14 EUR/min from the German fixed phone network and up to 0.42 EUR/min from mobile phone.<br/>Service Time: Monday to Friday, 09:00 to 12:30 and 13:30 to 17:30, GMT+1 or GMT+2 (Daylight Saving Time in Germany)<br/>* Except bank holidays in Hesse</p> | <p><b>Australia / New Zealand</b><br/>Tel: AU 1300 87 5465<br/>NZ 0800 87 5465<br/>E-mail: support.au@tp-link.com (AU)<br/>support.nz@tp-link.com (NZ)<br/>Service time: 24hrs, 7 days a week</p> <p><b>Turkey</b><br/>Tel: 0850 7244 488 (Turkish Service)<br/>E-mail: support.tr@tp-link.com<br/>Service time: 09:00 to 21:00, 7days a week</p> <p><b>USA / Canada</b><br/>Toll Free: +1 866 225 8139<br/>E-mail: support.usa@tp-link.com<br/>Service time: 24hrs, 7days a week</p> <p><b>Malaysia</b><br/>Tel: 1300 88 875 465<br/>E-mail: support.my@tp-link.com<br/>Service time: 24hrs, 7days a week</p> <p><b>Poland</b><br/>Tel: +48 (0) 801 080 618 / +48 227 217 563<br/>(if calls from mobile phone)<br/>E-mail: support.pl@tp-link.com<br/>Service time: Monday to Friday 09:00 to 17:00 P.M., GMT+1 or GMT+2 (Daylight Saving Time)</p> <p><b>Switzerland</b><br/>Tel: +41 (0) 848 800 998 (German Service)<br/>E-mail: support.ch@tp-link.com<br/>Fee: 4-8 Rp/min, depending on rate of different time<br/>Service time: Monday to Friday, 09:00 to 12:30 and 13:30 to 17:30, GMT+1 or GMT+2 (Daylight Saving Time)</p> <p><b>France</b><br/>Tel: +33 (0) 820 800 860 (French service)<br/>Email: support.fr@tp-link.com<br/>Fee: 0.118 EUR/min from France<br/>Service time: Monday to Friday 09:00 to 18:00 (Except French Bank holidays)</p> <p><b>Russian Federation</b><br/>Tel: 8 (499) 754 5560 / 8 (800) 250 5560<br/>(toll-free call from any RF region)<br/>E-mail: support.ru@tp-link.com<br/>Service time: From 10:00 to 18:00 (Moscow time)<br/>*Except weekends and holidays in Russian Federation</p> |
|---|--|