



User Guide

Kasa Smart Doorbell KD110

Contents

About This Guide	1	Smart Actions - Motion Sensing.....	30
Introduction	2	Voice & Third-Party Support	35
Appearance - Chime.....	3	Authentication.....	39
Appearance - Doorbell.....	4		
Set Up Your Kasa Smart Doorbell.....	5		
Main Device Controls	8		
Set Schedules	9		
Enable 24/7 Recording.....	11		
Check 24/7 Recording Videos.....	12		
Do Not Disturb.....	13		
Manage Device Settings	15		
Reset Your Smart Doorbell.....	27		

About This Guide

This guide provides a brief introduction to the Kasa Smart Doorbell and the Kasa Smart app, as well as regulatory information.

Features available in Kasa Smart may vary by model and software version. Kasa Smart availability may also vary by region. All images, steps, and descriptions in this guide are only examples and may not reflect your actual Kasa Smart experience.

Conventions

In this guide, the following convention is used:

Convention	Description
Teal	Key information appears in teal, including management page text such as menus, items, buttons and so on.
<u>Underline</u>	Hyperlinks are in teal and underlined. You can click to redirect to a website.

More Info

- Specifications can be found on the product page at <https://www.tp-link.com>.
- Our Technical Support and troubleshooting information can be found at <https://www.tp-link.com/support/>.
- A TP-Link Community is provided for you to discuss our products at <https://community.tp-link.com>.
- Frequently Asked Questions (FAQs) can be found at <https://www.tp-link.com/support/fag/>.

Introduction

Replace your existing wired doorbell with a smarter one and answer your door from anywhere with your phone. Receive instant notifications whenever someone comes by—even before they knock. Keep an eye out for your deliveries, visitors, or possible intruders 24/7 with crystal clear video and audio. It allows you to see visitors, as well as monitor intruders or package deliveries.

With a microSD card, the doorbell can store up to 128GB of video.



HD Video



Person Detection



Secure Local Storage



Two-Way Audio



Indoor Chime Provided



**All-Weather
All-Star**

- **HD Video** – Sharp and clear high resolution offers greater detail and colors, even when you zoom in.
- **Person Detection** – Send person alerts to differentiate people and other motion activity.
- **Local and Cloud Storage** – Save your footage continuously on a microSD card[†] or subscribe to a Kasa Care Plan[‡] to store video clips to the cloud.

Up to 128GB microSD card is supported.

[†]microSD card not included.

[‡]Kasa Care Plans vary by country and region.

- **Live View with Two-Way Audio** – Watch live video and carry on a conversation from anywhere with your phone or other supported device.
- **Indoor Chime Provided** - Choose from a variety of ringtones to get alerted immediately when you are at home.
- **All-Weather All-Star** - IP64 certified weatherproofing ensures your doorbell stays protected against rain and dust.

Appearance - Chime

Kasa Smart Doorbell is made up of a Chime and a Doorbell.

The Chime has a system LED that changes color according to its status, a sync button, a music button, and a volume button. Refer below for details.

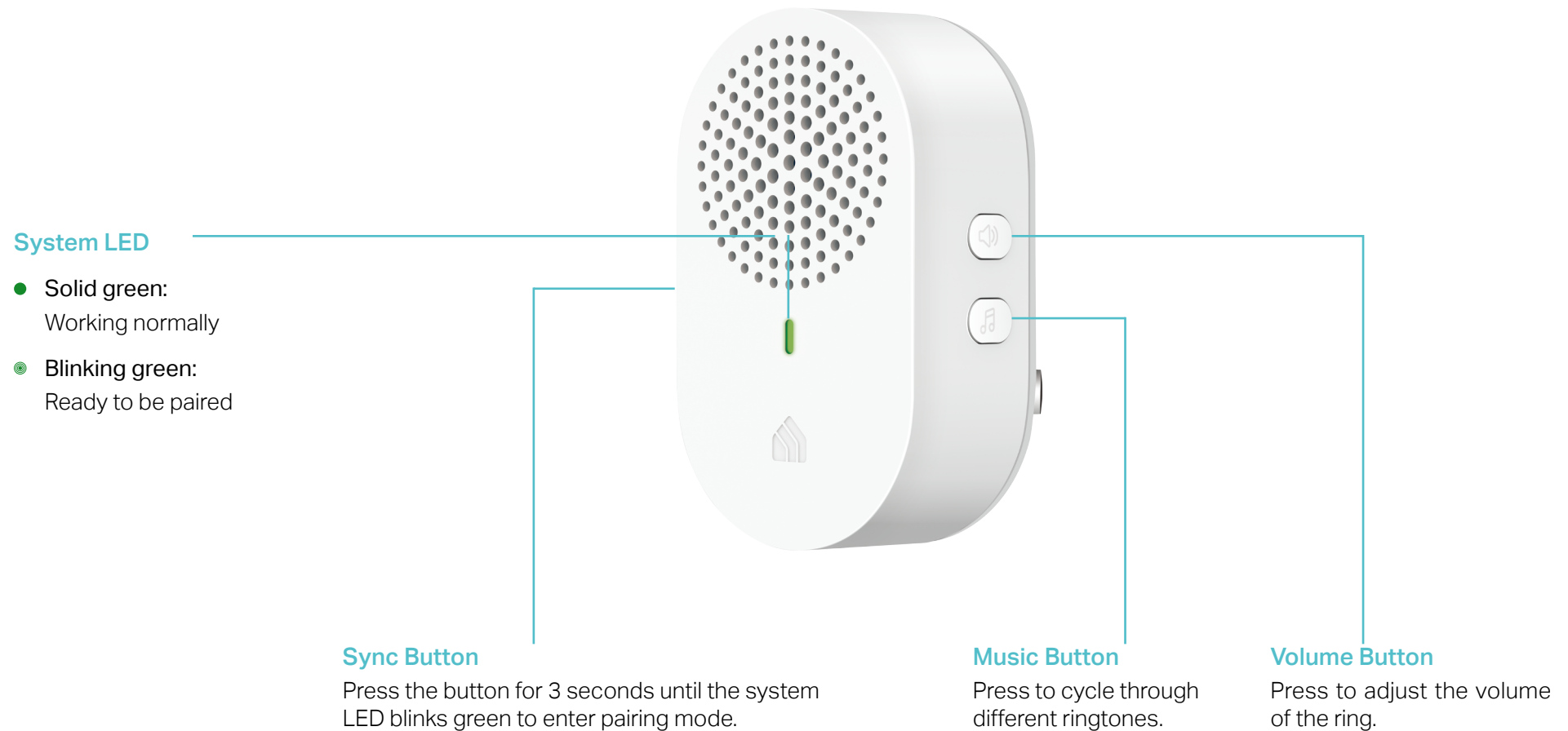

Appearance - Doorbell

The doorbell has a ring button, a status LED, and a microSD card slot. Refer below for details.

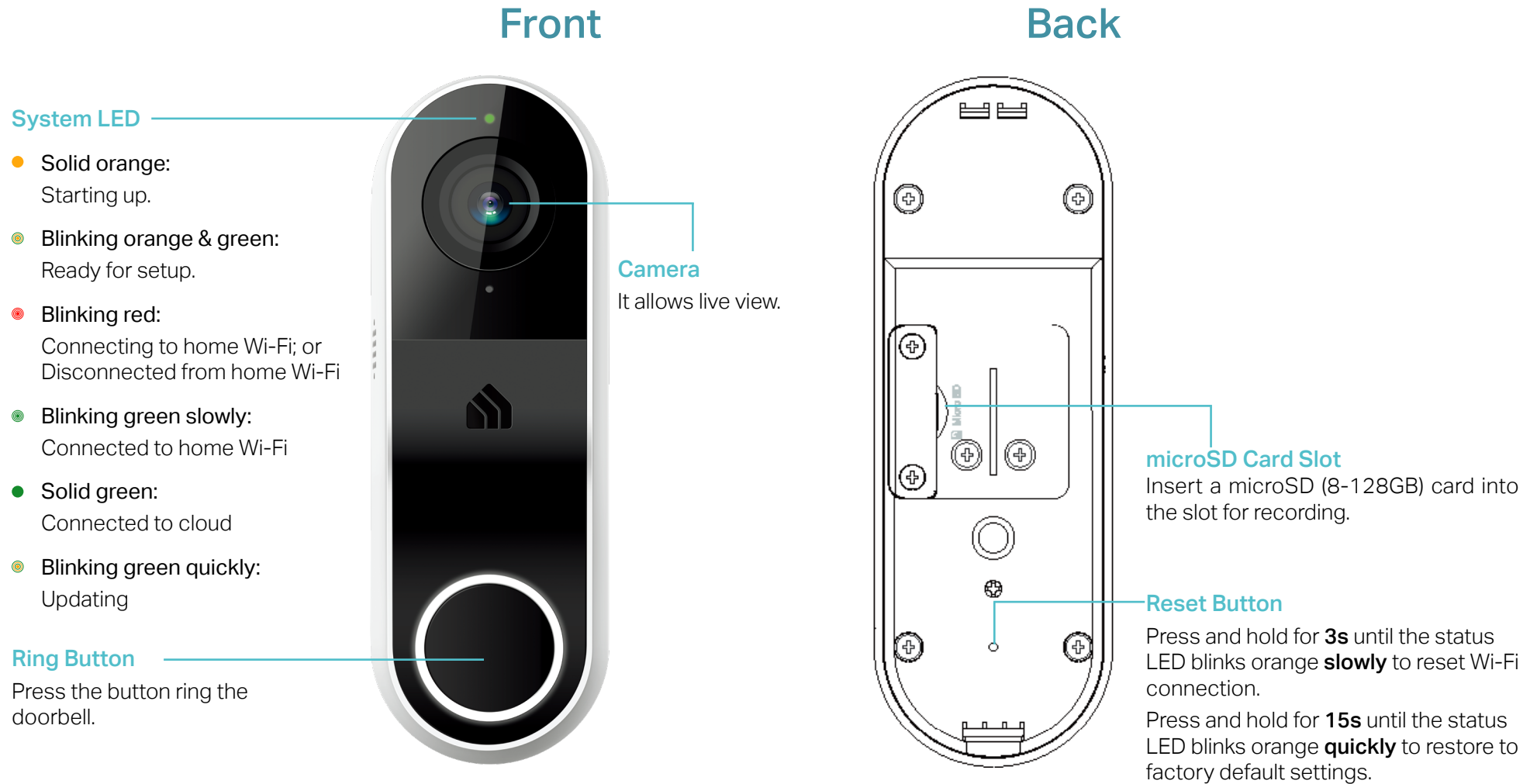

Set Up Your Kasa Smart Doorbell

Follow the steps below to get started with your new Kasa Smart Doorbell.

Step 1. Download Kasa

Get the [Kasa Smart](#) app from the App Store or Google Play, or by scanning the QR code below.



Step 2. Log In

Open the app, and log in with your TP-Link ID. If you don't have an account, create one first.

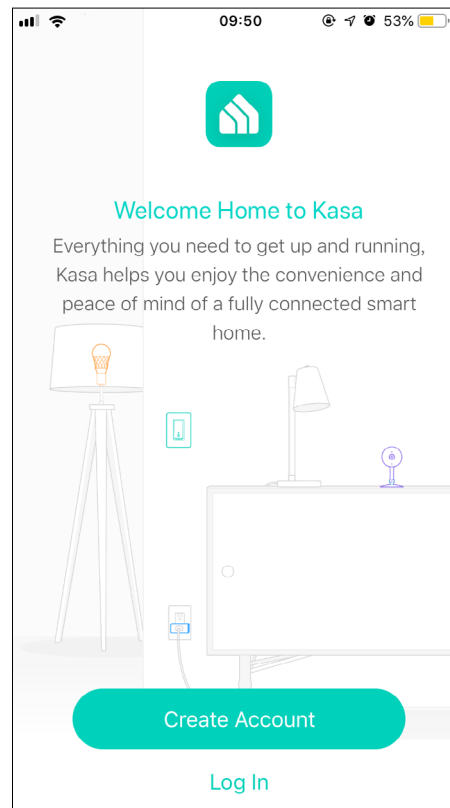

Step 3. Add Device

Tap the  button in the Kasa app and select [Doorbells](#).

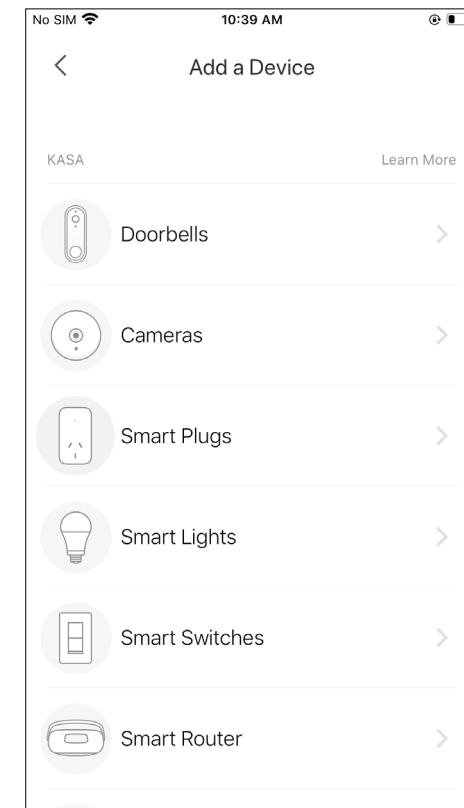

Step 4. Insert a microSD Card

If you want to record videos locally, you'll need to insert a microSD card by removing the two screws on the back of the doorbell.



Step 5. Install your doorbell

Follow app instructions to install your doorbell. Below are the size of screws:

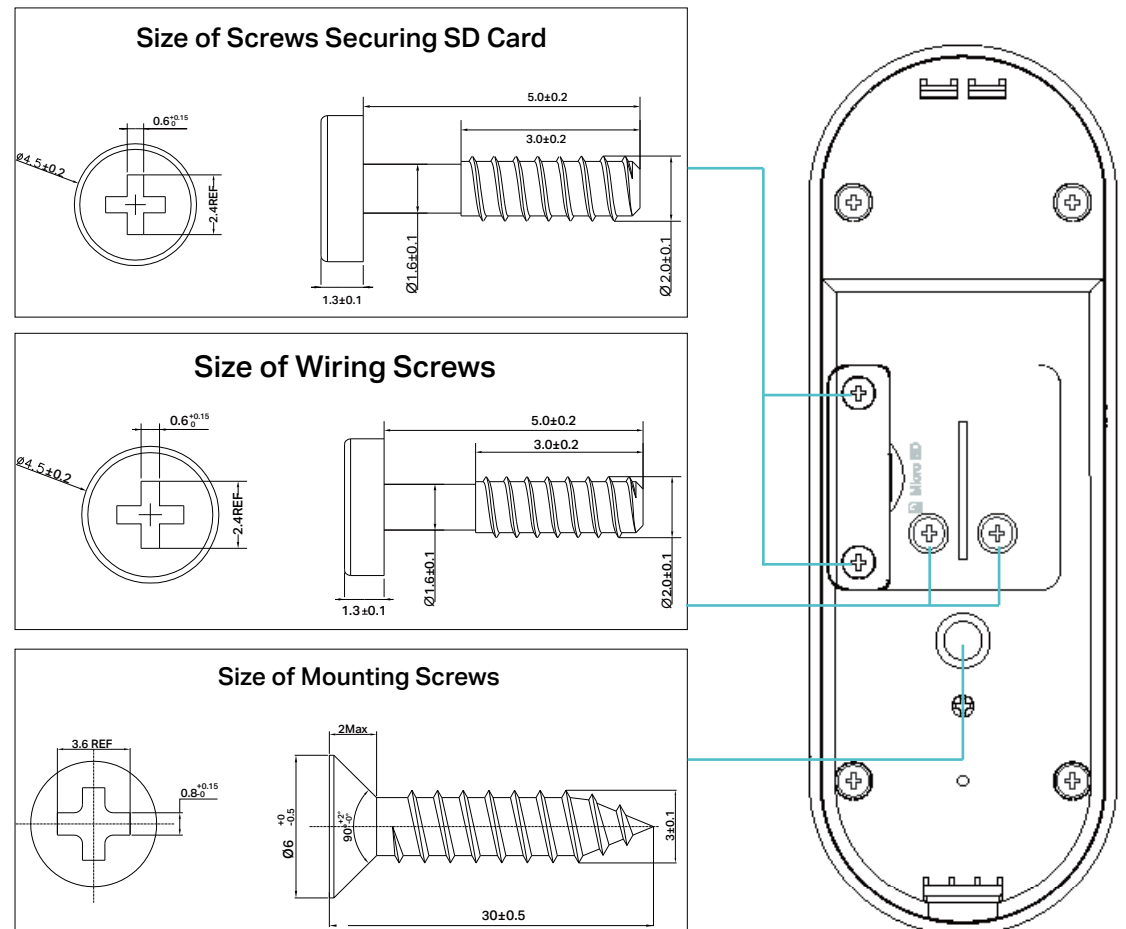

Step 6. Set Up

Follow app instructions to set up your doorbell and pair with your chime.

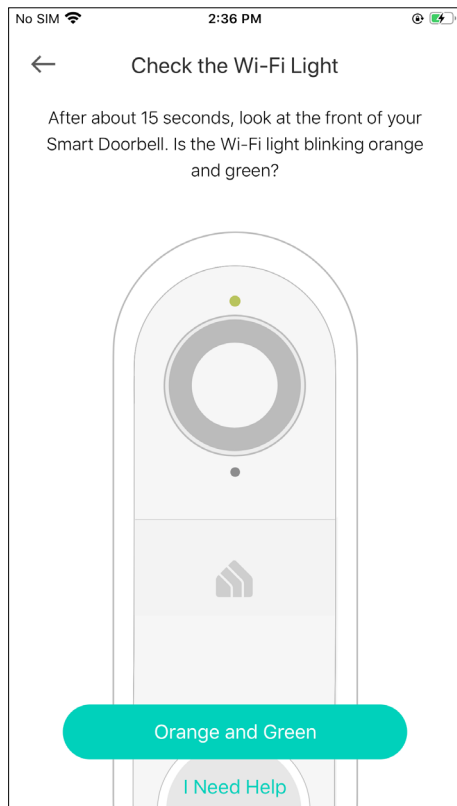

Main Device Controls

After you successfully set up your Smart Doorbell, you will see the home page of the Kasa Smart app. Here you can view and manage all devices that you've added to Kasa. Tap your smart doorbell to enter the live view page and further manage it.

Home Page

You can see all your Kasa devices listed in the Home page.

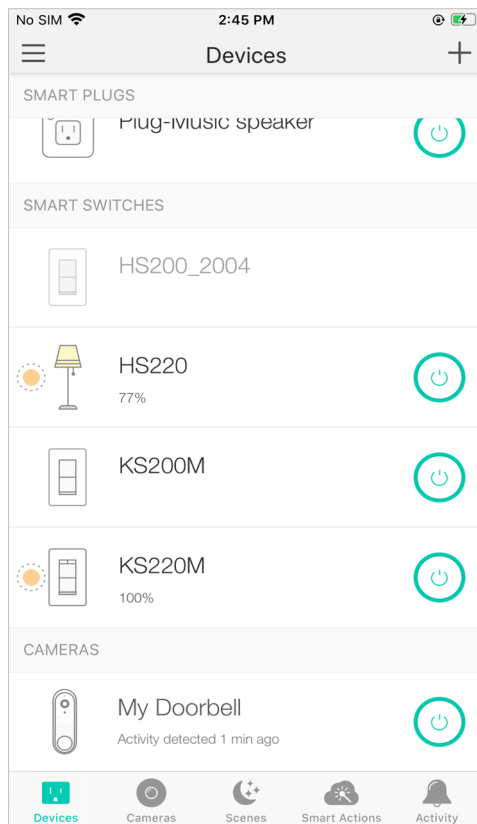

Turn On/Off Your Kasa Smart Doorbell

Turn on/off your Smart Doorbell quickly by tapping the switch on the home page, which means you are entering the privacy mode and cannot stream live video.

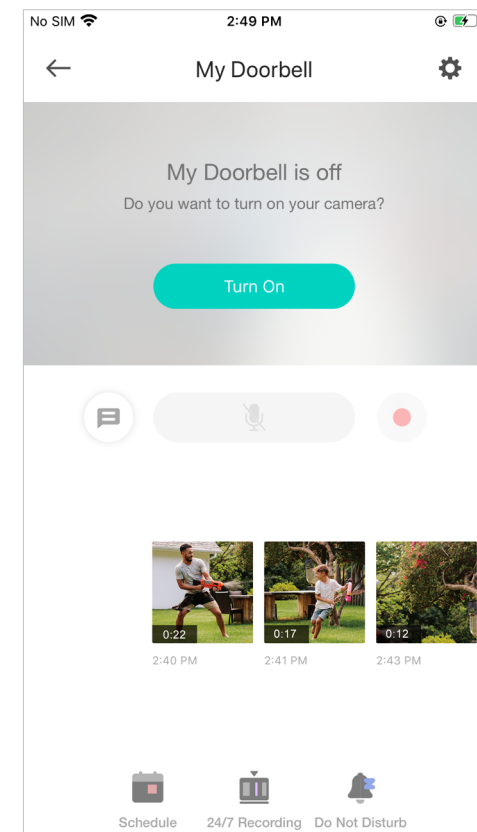
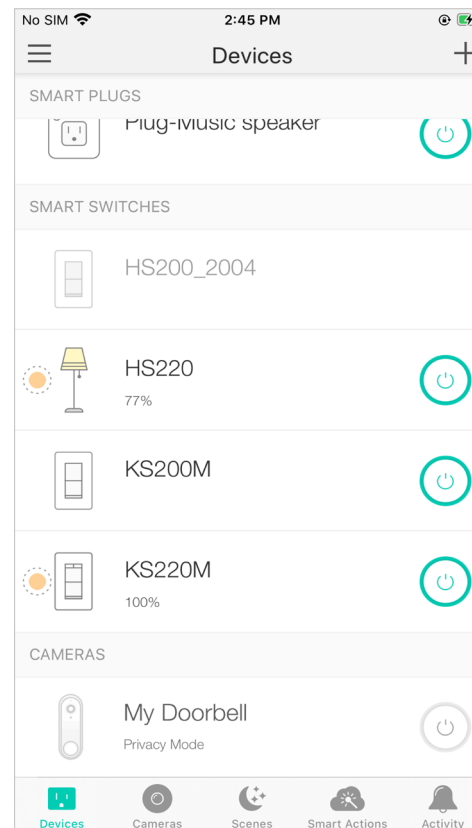

Set Schedules

Set schedules to automatically turn on/off your doorbell at set times according to your daily routine.

1. Tap your Smart Doorbell in the Home page to enter the live view page, and then

tap  .

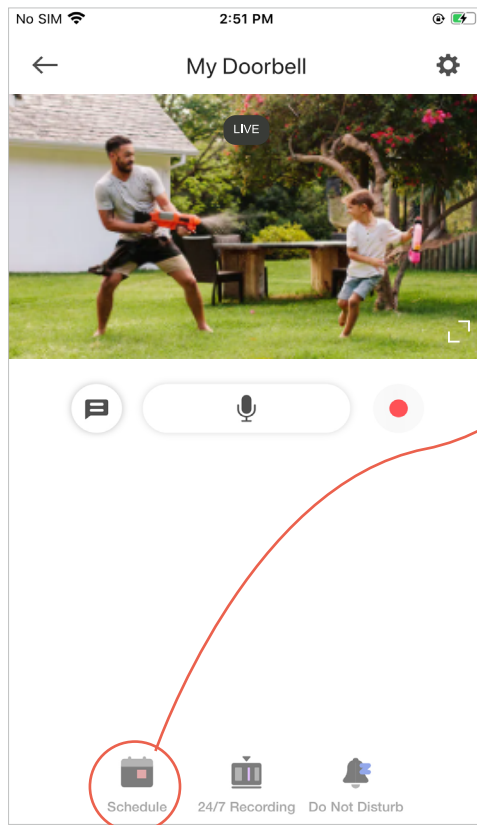

2. Tap + on the top right corner.

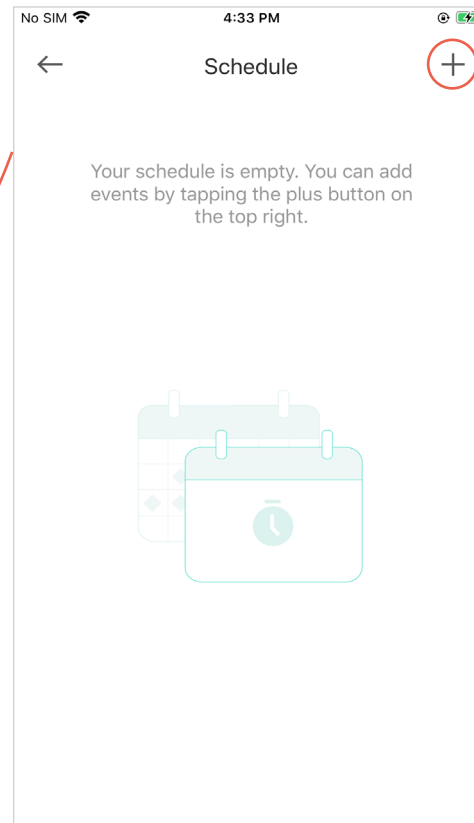

3. Set a schedule to turn your Smart Doorbell on or off.

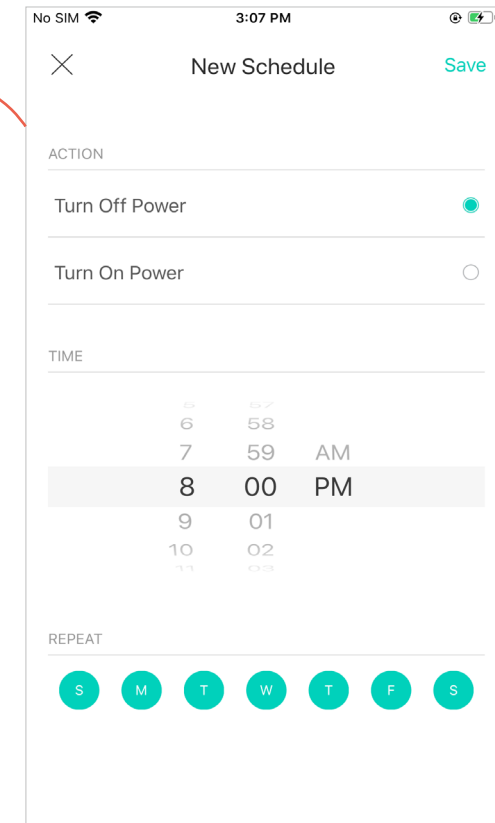

4. Tap [Save](#) and you'll see your schedule listed in the [Schedule](#) Page. You can add more schedules following the same steps.

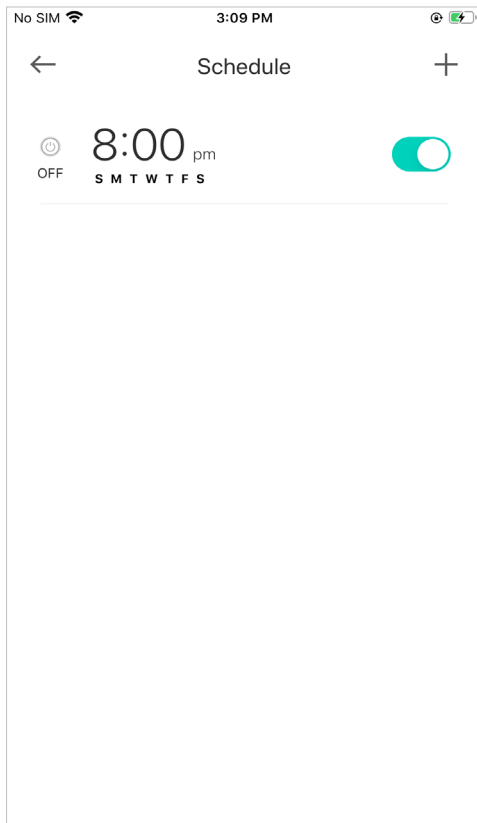

5. You can turn off your schedule any time at the [Schedule](#) page.

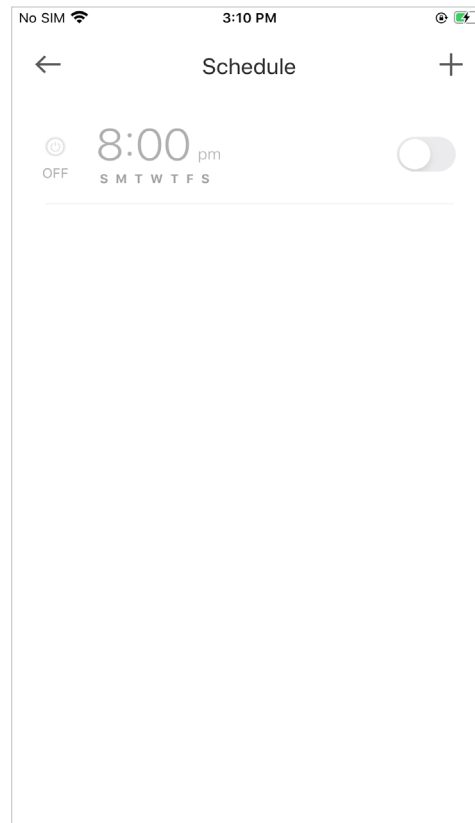

Enable 24/7 Recording

When 24/7 Recording is enabled, your camera record every minute of every day so you'll never miss a thing.

Note: You need to insert a microSD card first.

In the live view page, tap  then [24/7 Recording](#). You can enable or disabled the feature and check the storage of your microSD card.

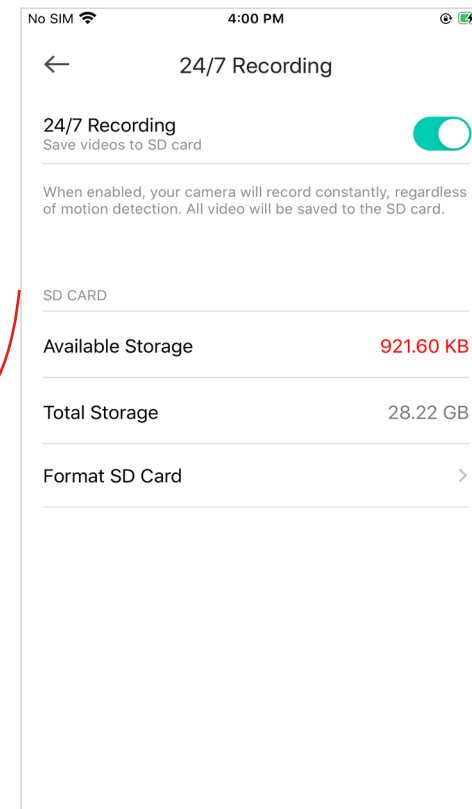
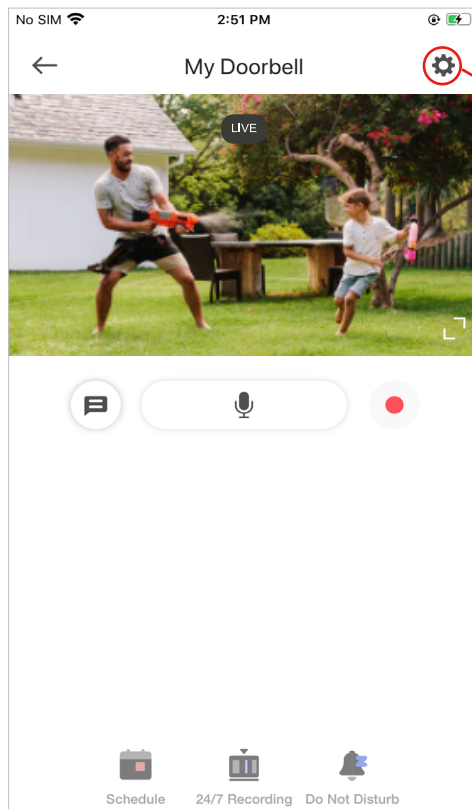

Check 24/7 Recording Videos

The recorded videos are saved in the microSD card. You can check it in the app.

In the Home page to enter the live view page, tap . You will see recorded videos.

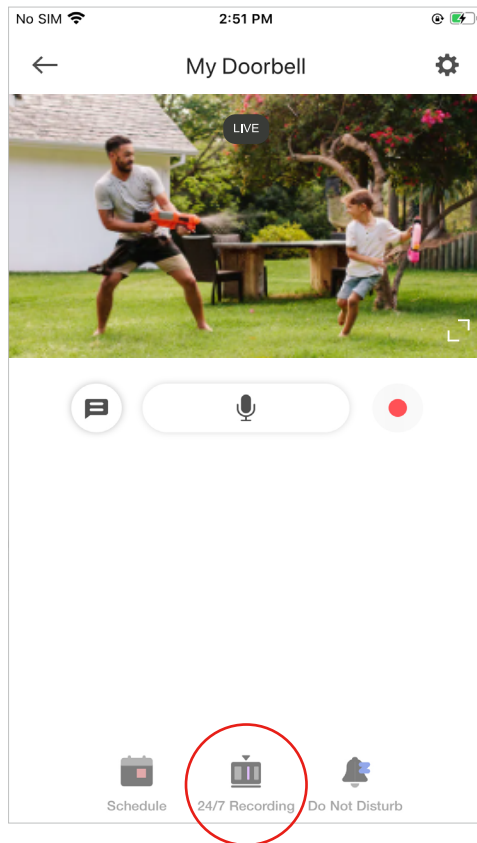

Do Not Disturb

When enabled, the doorbell will not ring and no push notifications will be sent. You can go to Activity to check the records. You can turn it on when you do not want visitor to disturb you.

1. Tap your Smart Doorbell in the Home page to enter the live

view page, and then tap  Do Not Disturb.

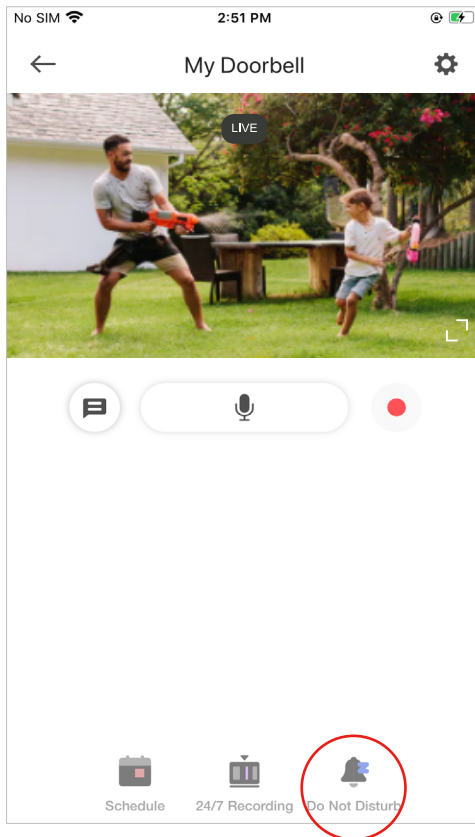

2. Add a [Do Not Disturb](#) schedule.

Note: [Do Not Disturb](#) turns on when the schedule starts, and turns off the schedule ends. You can turn [Do Not Disturb](#) on or off, the next schedule will still activate.

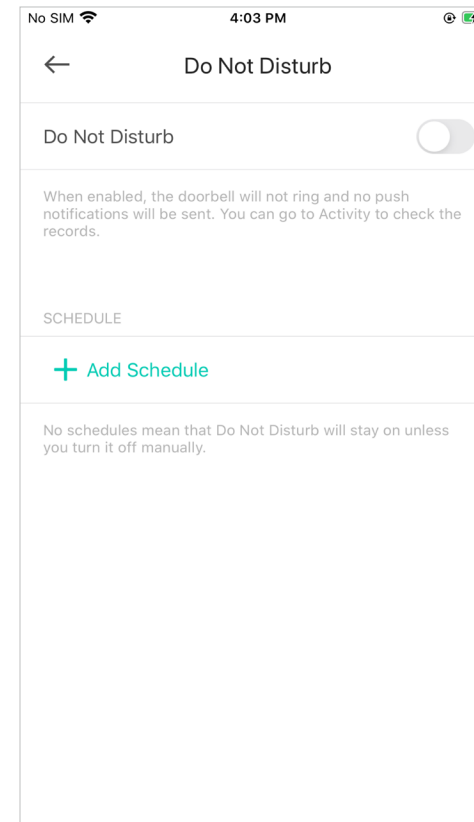

3. Set schedules to turn on **Do Not Disturb** automatically at set times.

For example, I don't want to be disturbed from 1:00 PM to 3:00 PM every Saturday and Sunday.

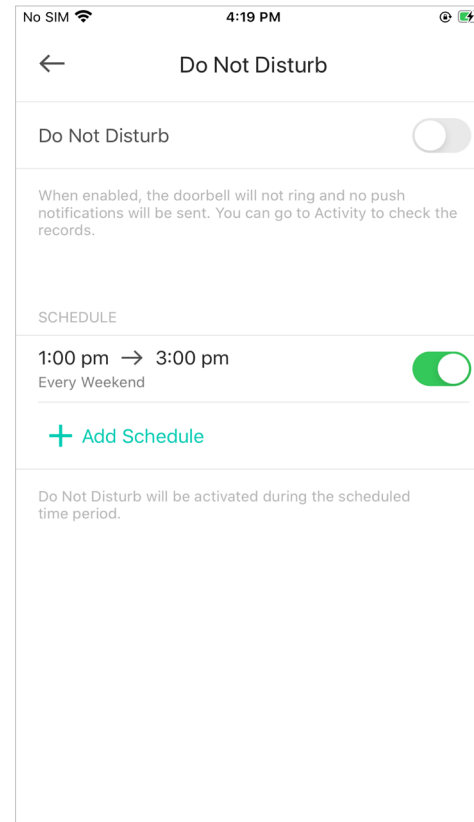
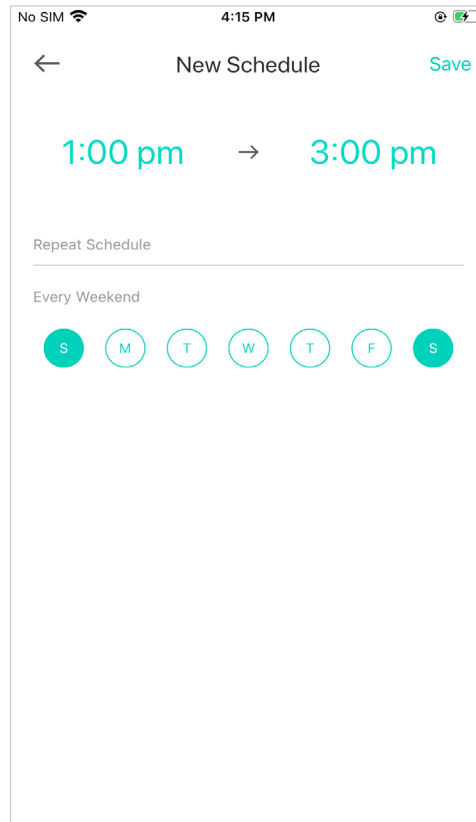
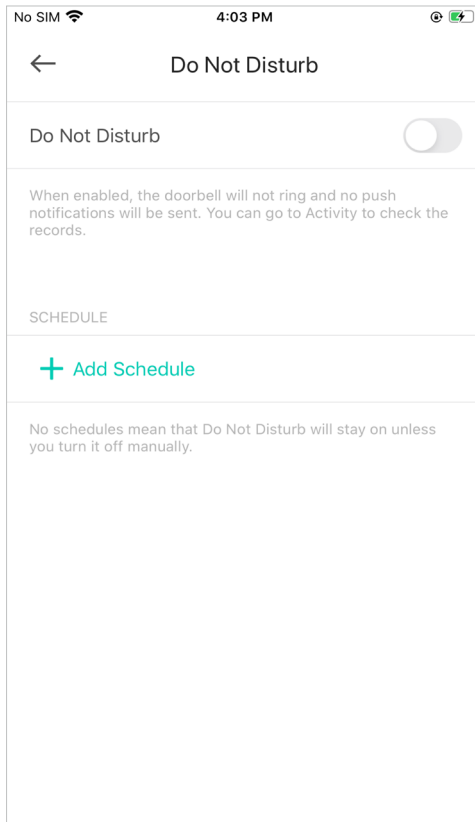

Manage Device Settings

1. Tap your Smart Doorbell in the Home page to enter the live view page and then tap  .

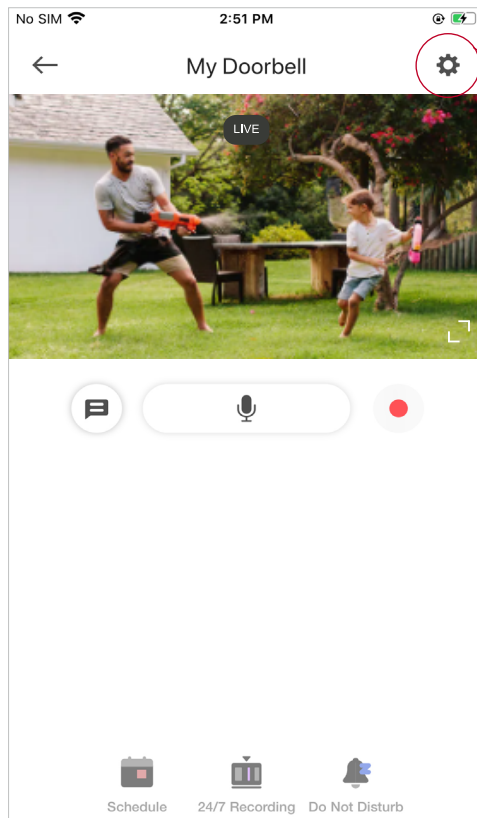

2. Turn on or off the camera.

When **Camera** is turned off, it means privacy mode is enabled. You can turn the camera off when you do not want your doorbell to stream live view and record videos.

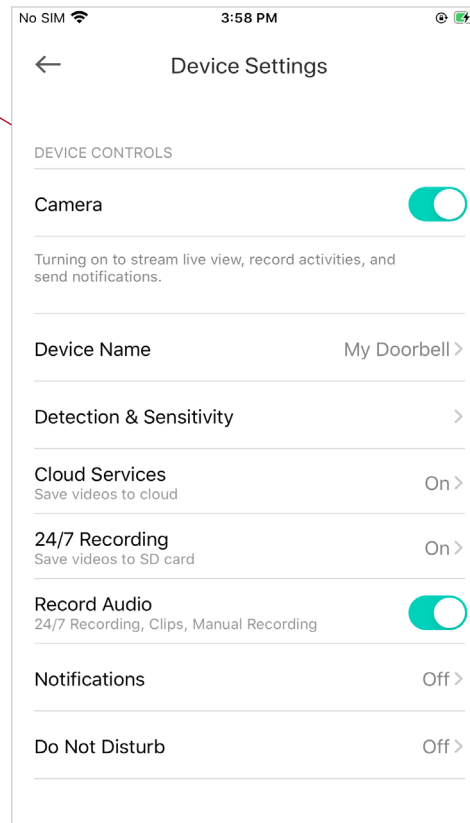

3. Edit device name.

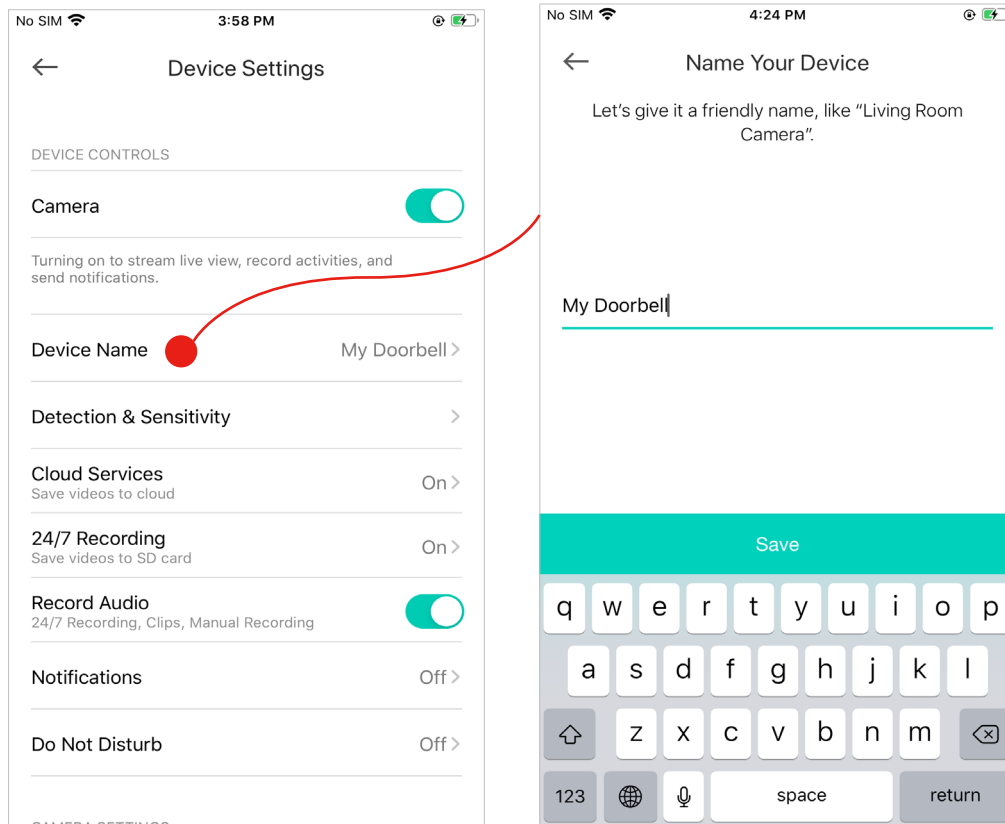

4. Set detection and sensitivity for recording videos.

Enable [Detect Motion](#) / [Detect Person](#) if you want your doorbell camera to record when motion / person is detected. Also set the sensitivity of detection.

Enable [Listen for Sound](#) if you want your doorbell camera to record when sound is detected and set its sensitivity.

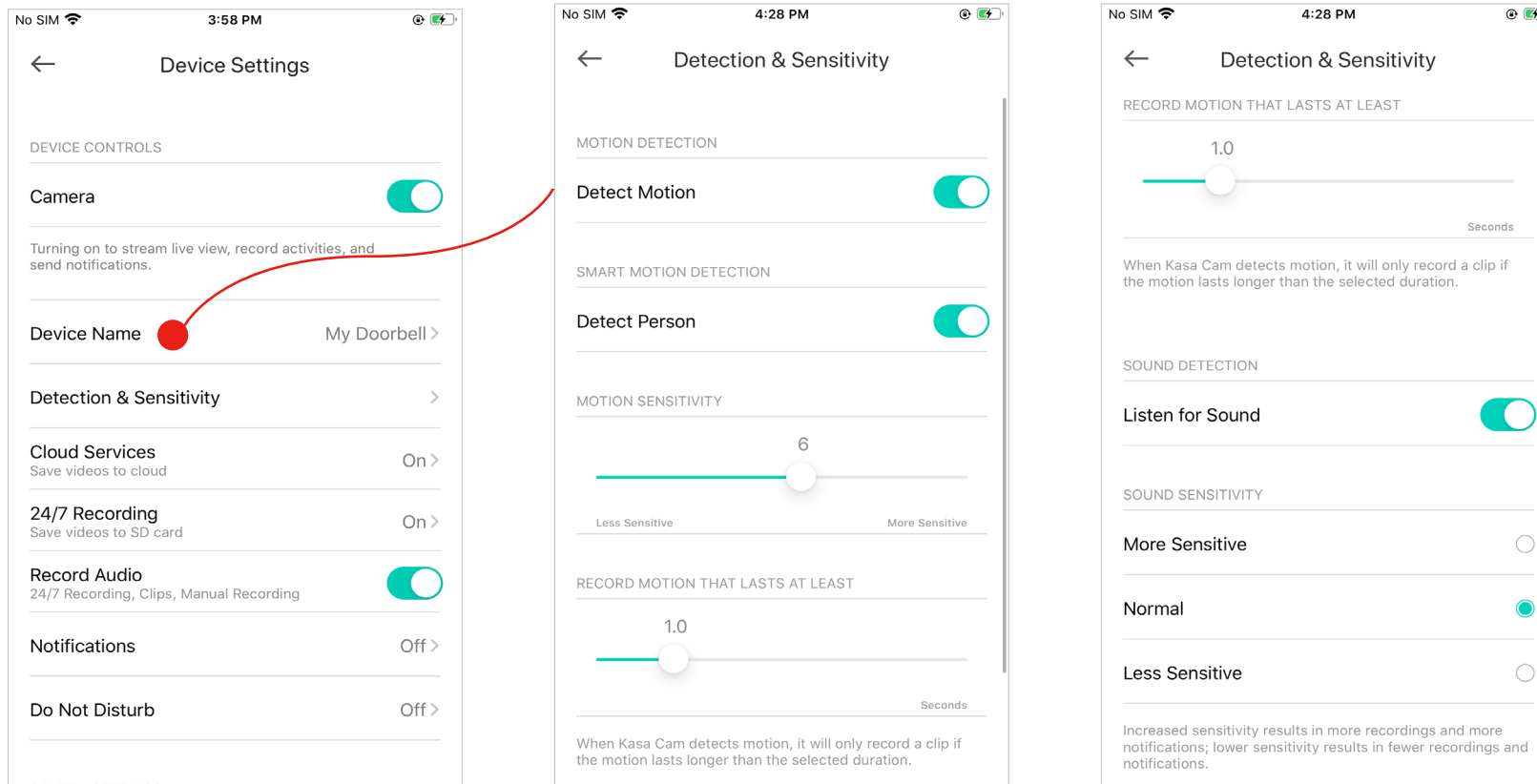

5. Enjoy cloud service.

If you have subscribed to Kasa Care, you can enable [Cloud Services](#) to save the videos recorded by your doorbell to the cloud. Kasa offers unlimited cloud storage.

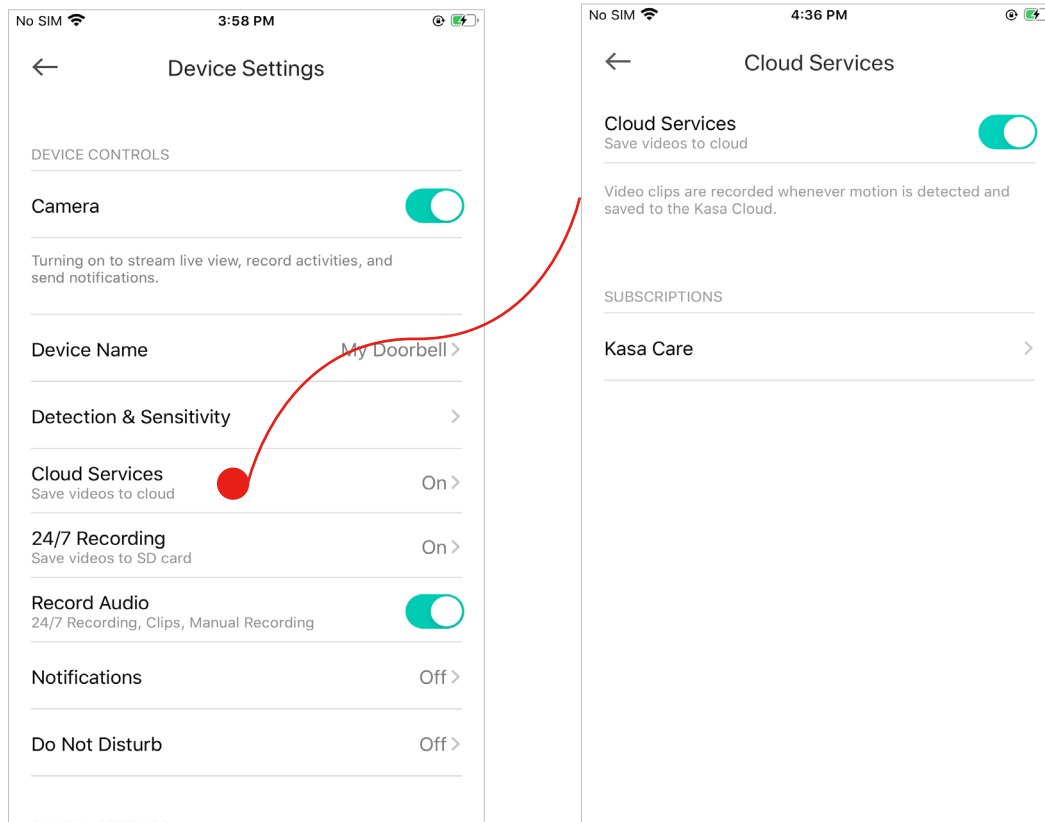

6. Choose whether to record audio.

Enable [Record Audio](#) if you want to also record sound during recording.

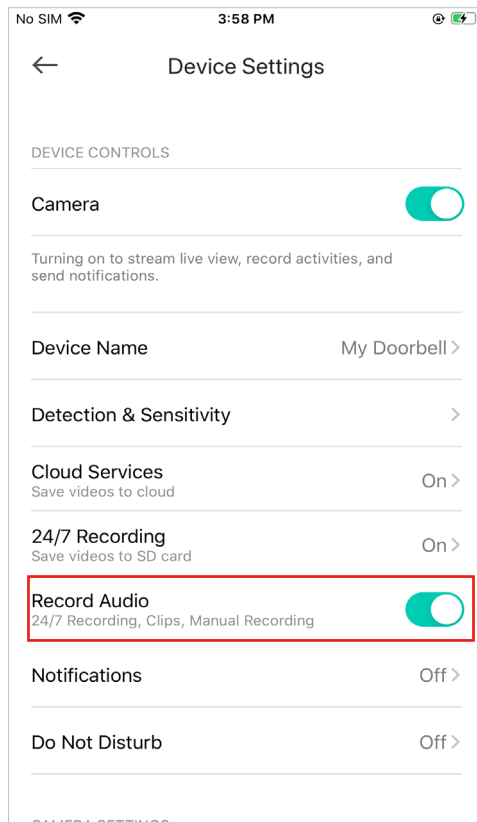

7. Choose whether to receive notifications.

Enable [Person Detected](#) / [All Other Motion & Sound](#) / [Doorbell is Pressed](#) if you want to be notified when person / all other motion and sound / doorbell press is detected. You can also select the time when you want to receive notifications.

If you don't want to be bothered by frequent notifications, enable [Automatically Limit Notifications](#).

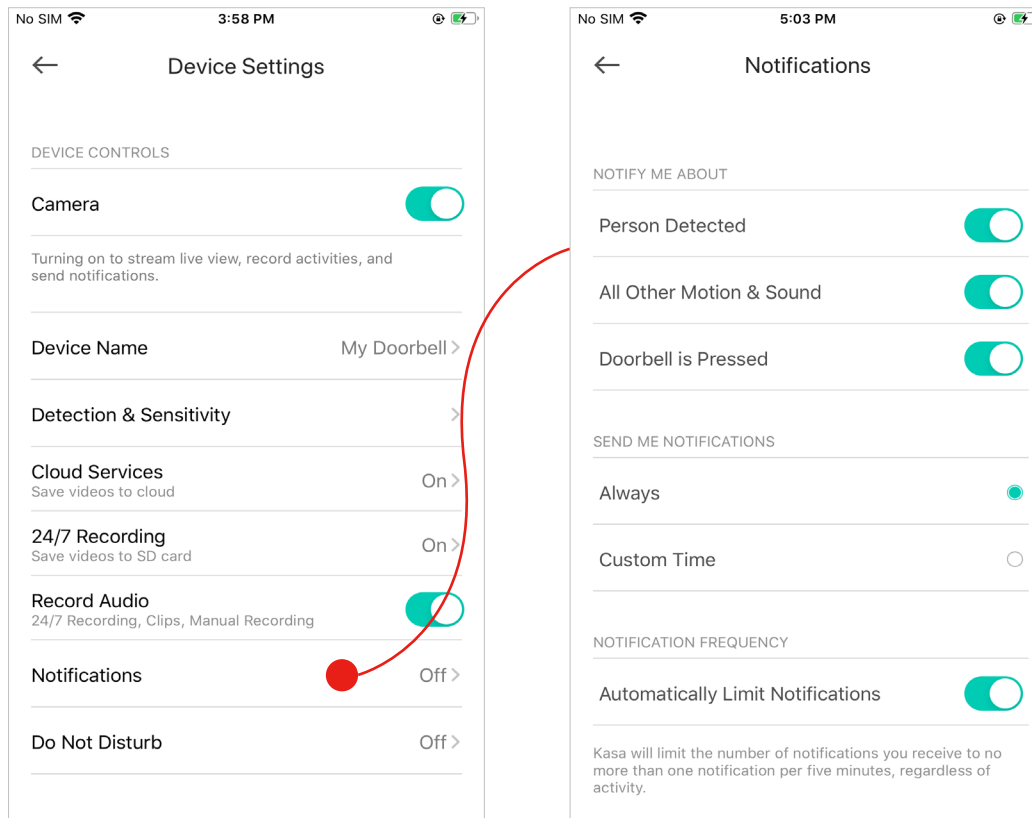

8. Set activity zones.

Control what alerts you by creating multiple custom activity zones around areas that are important to you

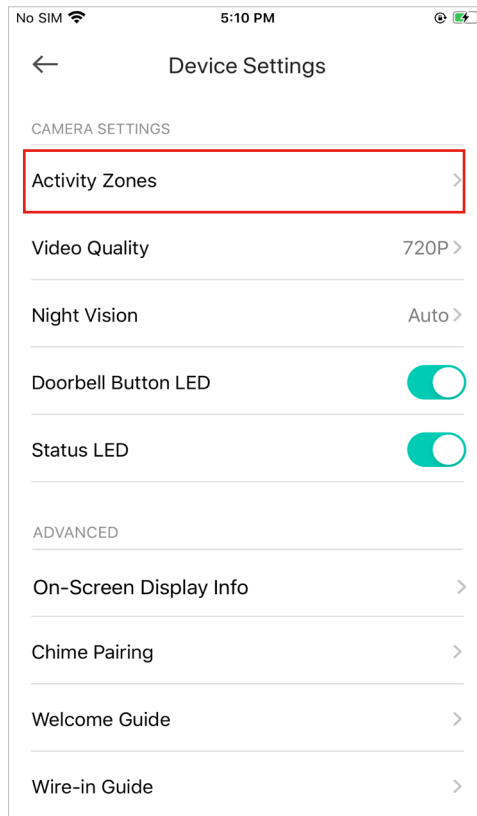

9. Choose the resolution for videos.

The highest quality looks better but requires faster internet connection and larger size for saving the videos.

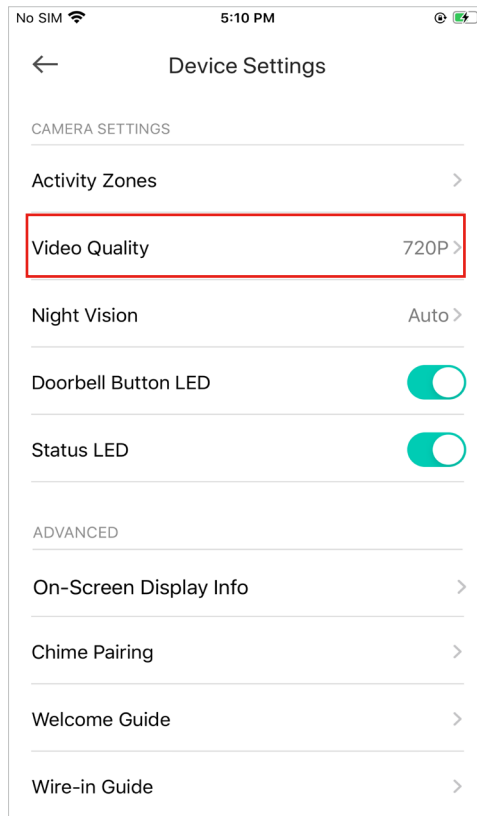

10. Choose when you want the night vision to be on.

Night vision allows you to see clearly at night. You can choose **Automatic** to turn on night vision automatically in low light conditions and turn off in daylight.

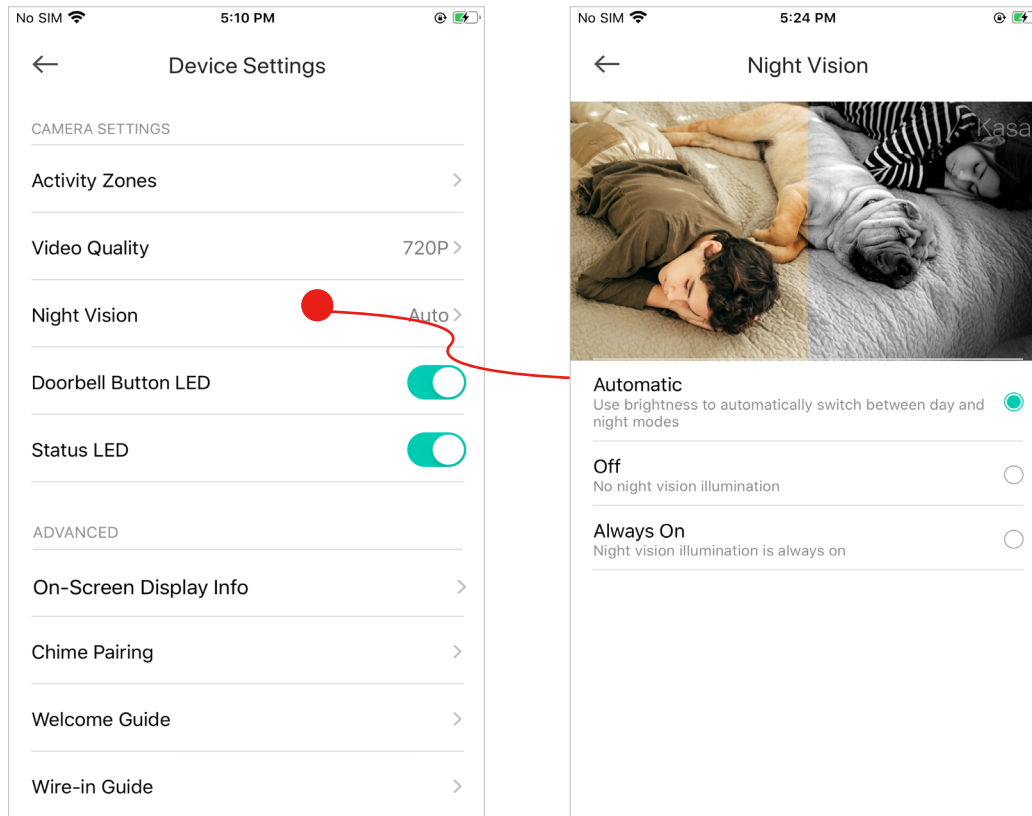

11. Turn on/off Doorbell Button LED.

Turn on or off the button LED on the doorbell.

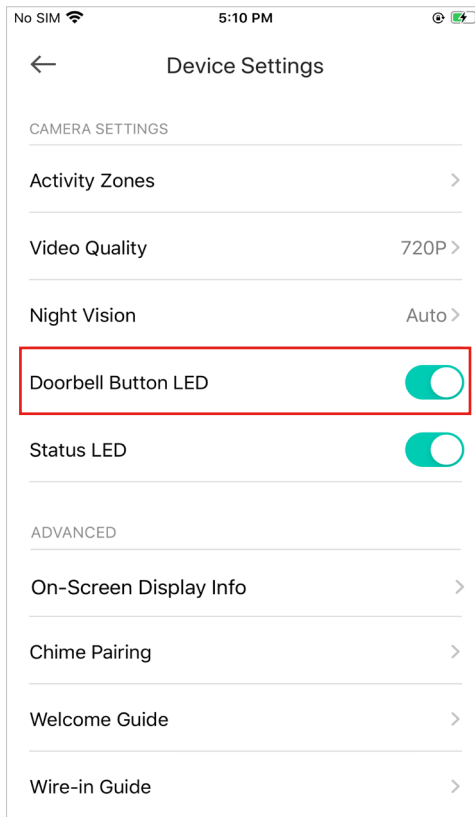

12. Turn on/off Status LED.

Turn on or off the status LED on the doorbell.

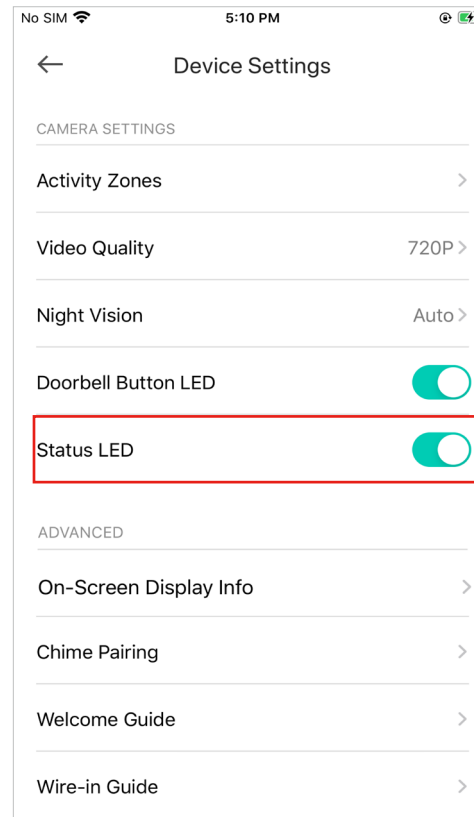

13. Customize on-screen display information.

Choose whether you want to display time stamp or logo on the Live View screen.

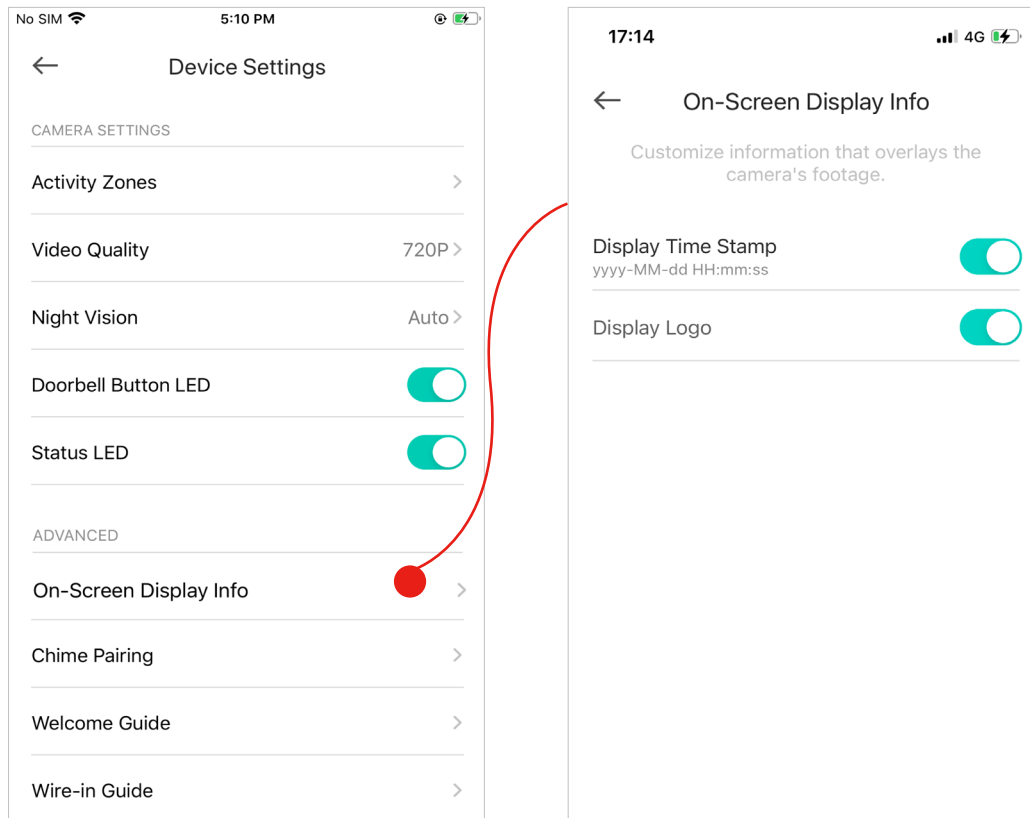

14. Pair your chime.

Tap [Chime Pairing](#) and pair your chime with the doorbell.

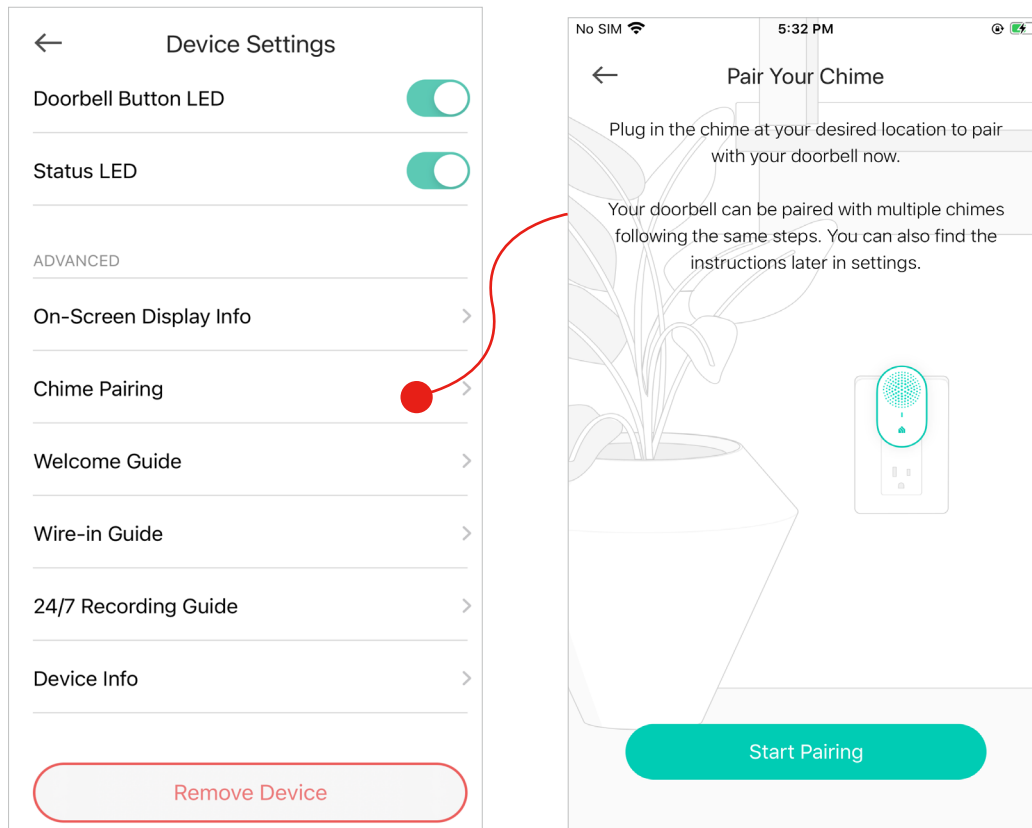

Reset Your Smart Doorbell

TP-Link provides three methods to reset your Smart Doorbell.

Method 1

Use a pin to press and hold the Reset button for **5s** to reset Wi-Fi connection.

Use a pin to press and hold the Reset button for **15s** to restore to factory default settings. .

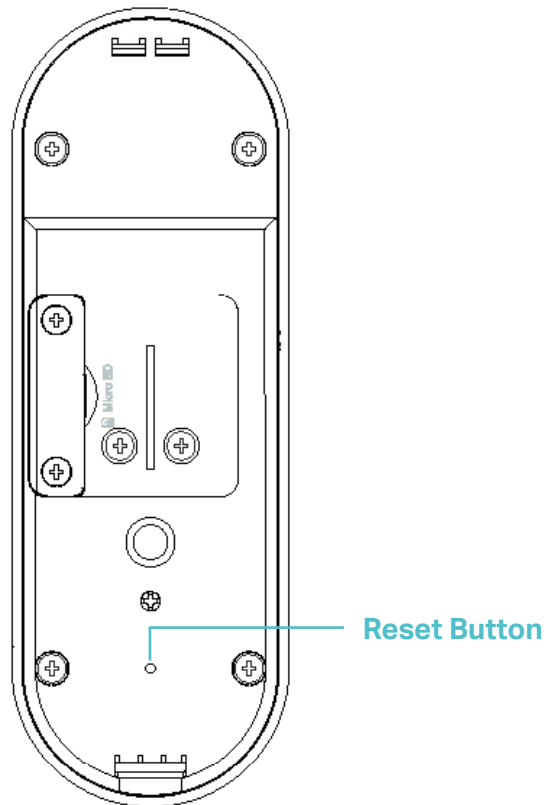

Method 2

Swipe left your Smart Doorbell on the [Devices](#) page and tap [Delete](#). Then tap [Remove Device](#). Your Smart Doorbell will be removed from your Kasa account and restored to factory settings.

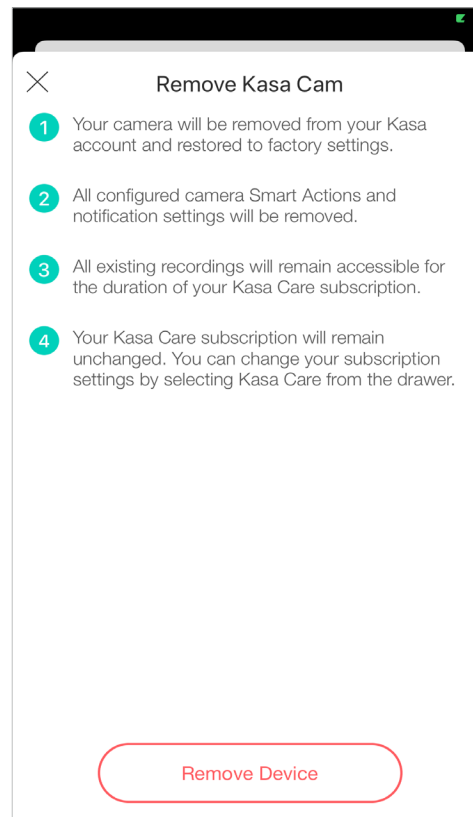
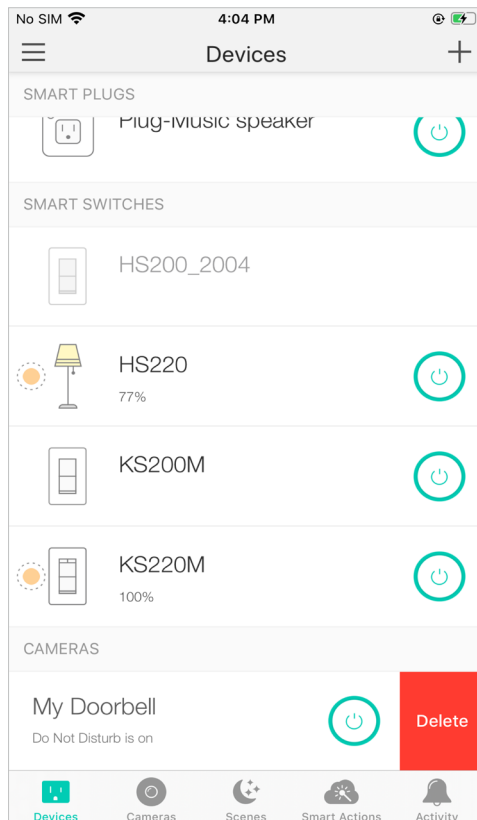

Method 3

Tap your Smart Doorbell and go to the [Devices Settings](#) page. Then tap [Remove Device](#) in the bottom. Your Smart Doorbell will be removed from your Kasa account and restored to factory settings.

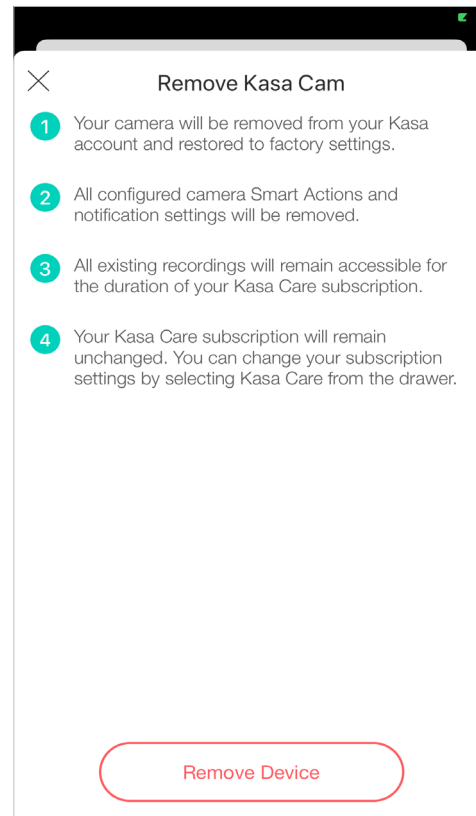
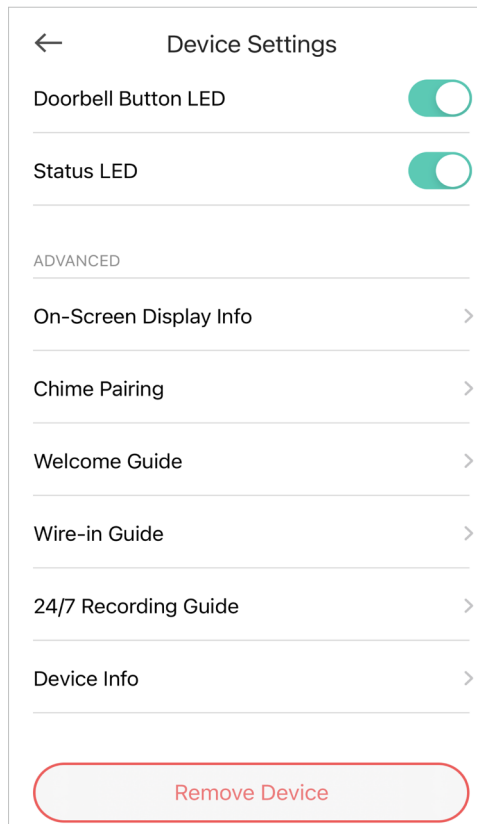

Smart Actions - Motion Sensing

Smart Actions is a function provided that allows device interconnections and home automations. With Smart Actions, your Kasa devices can work together to create a smarter smart home. From the moment you wake up to the moment you drift asleep, Smart Actions make your home safer and more comfortable. There are four types of smart actions. For your Kasa Smart Doorbell, you can set Motion Sensing action.

1. Tap  at the bottom, then tap **Add an Action.**

2. Select an automation type for your Smart Actions. Here we choose **Motion Sensing.**

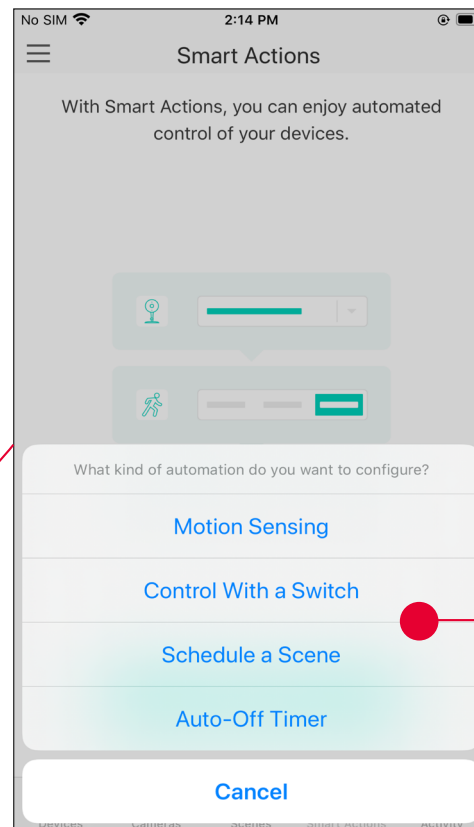
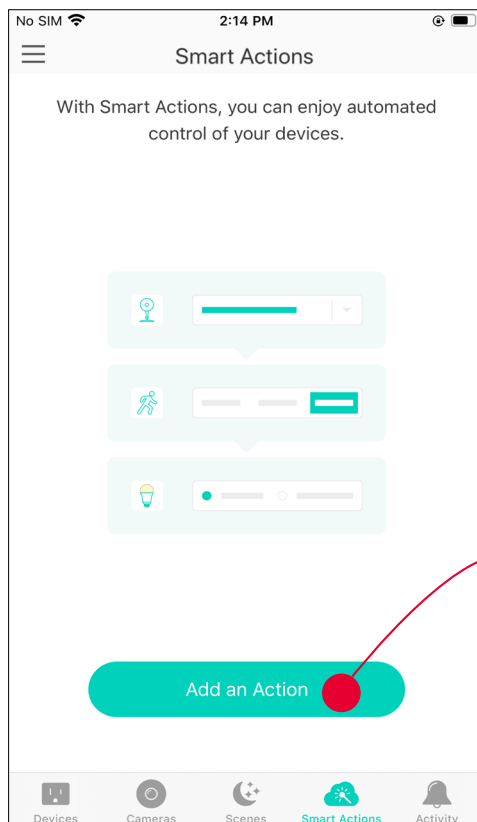

Motion Sensing: Take actions when a Kasa camera senses a motion.

Control With a Switch: Extend the Smart Switch control to other Kasa Smart devices. Turn on/off a group of devices with the Smart Switch all together.

Schedule a Scene: Schedule a "Scene" to be turned on automatically at the time specified.

Auto-off Timer: Whenever a smart device is turned on, turn it off after the designated amount of time.

Configure Motion Sensing if you also have another Kasa smart device

E.g. I want to turn my Kasa light switch on when my doorbell senses a motion.

1. Tap **Motion Sensing** then select your doorbell.

2. Select your Smart Light Switch.

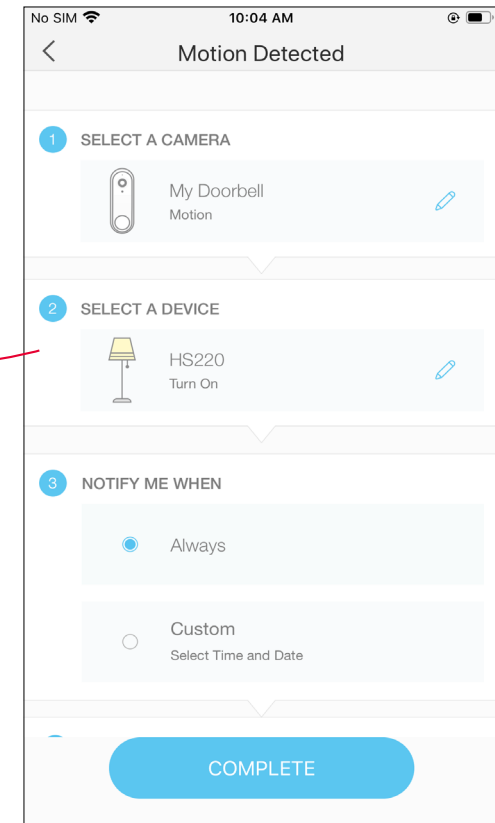
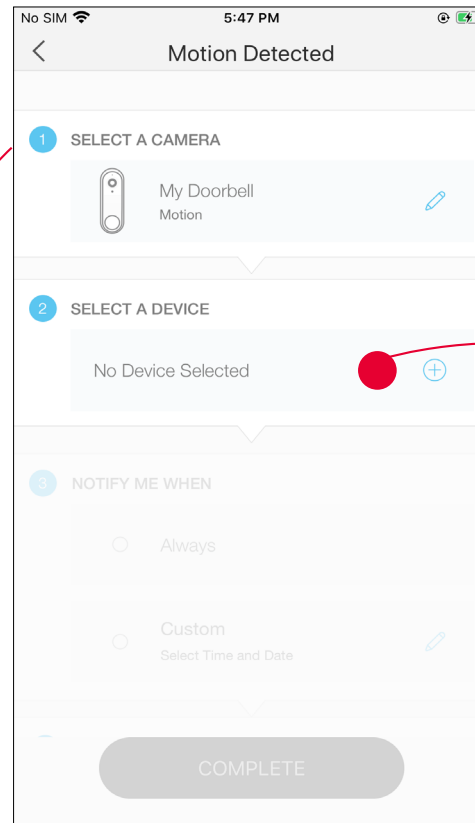
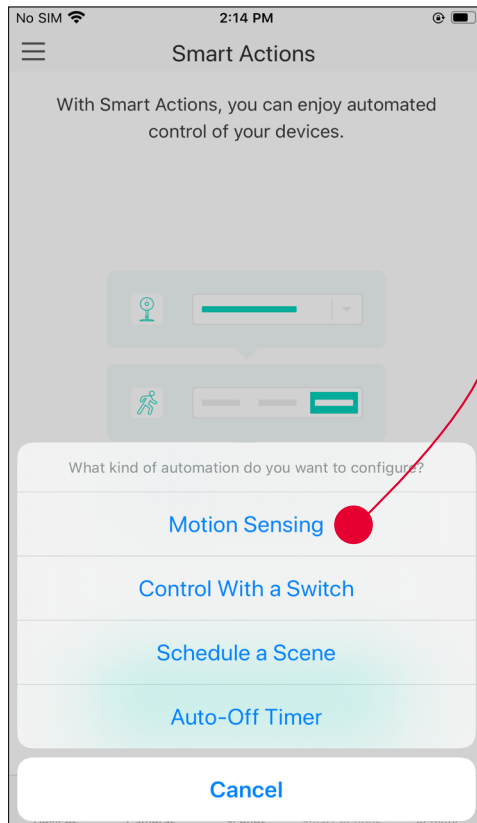

3. Set the time when you want the action to run. You can choose [Always](#) or tap [Custom](#) to choose time according to your needs.

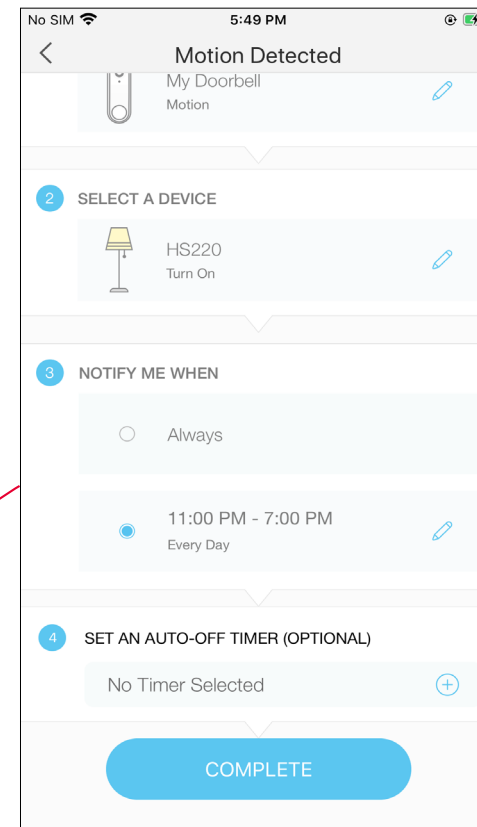
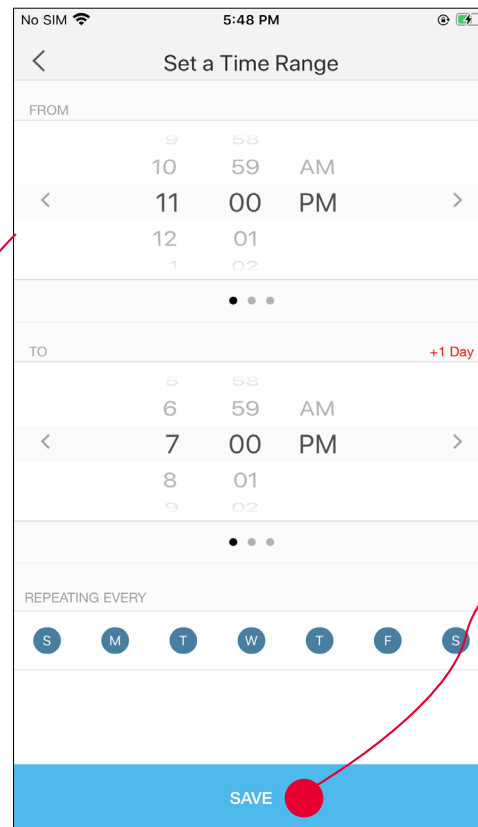
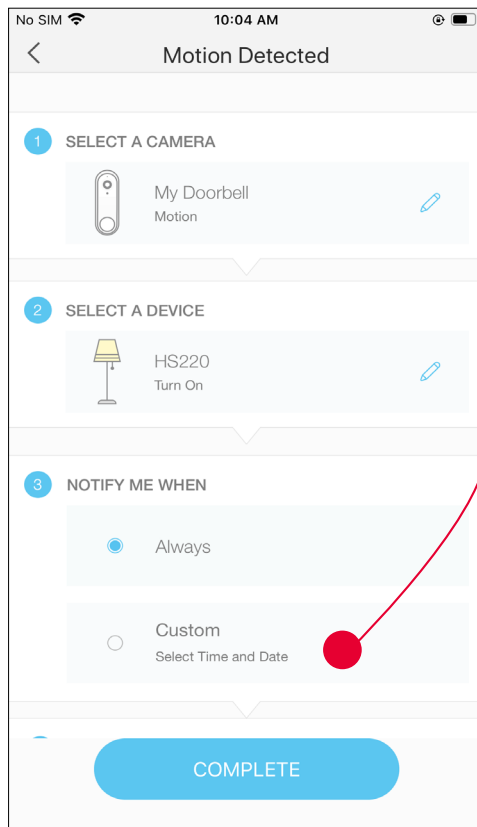

4. (Optional) Set an auto-off timer then tap **Complete**. Then your light will be turned off after the time you set.

5. Name your action for easy identification.

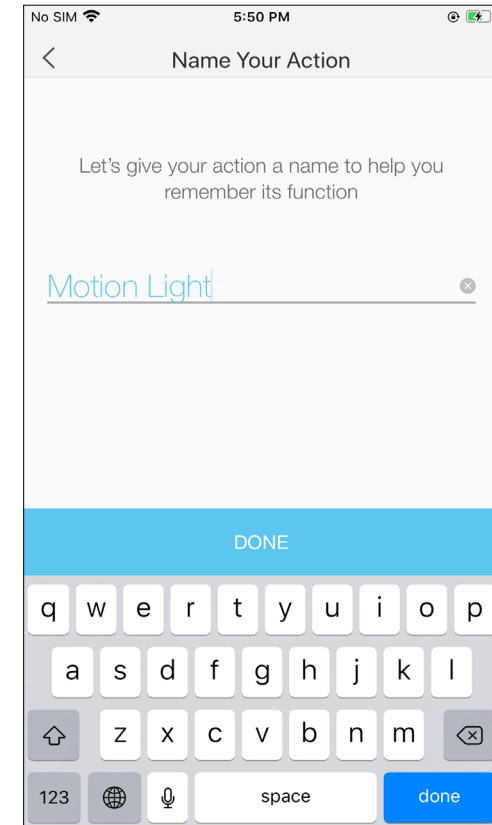
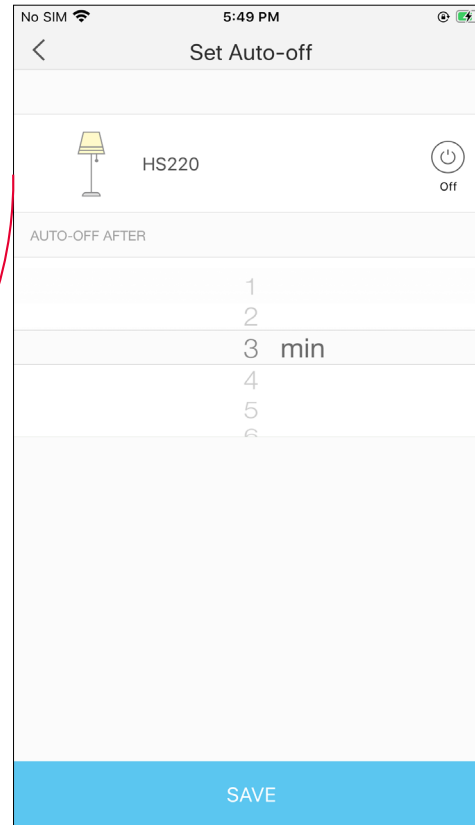
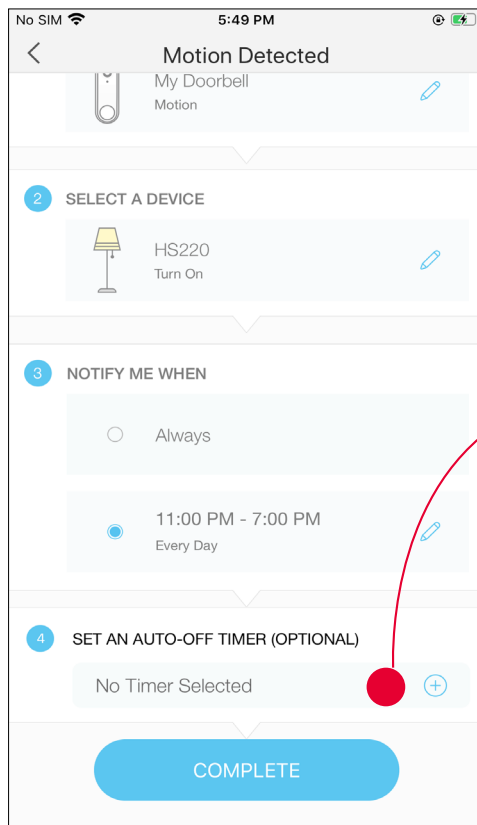

6. The Smart Action is created successfully and displayed in the Smart Actions list.

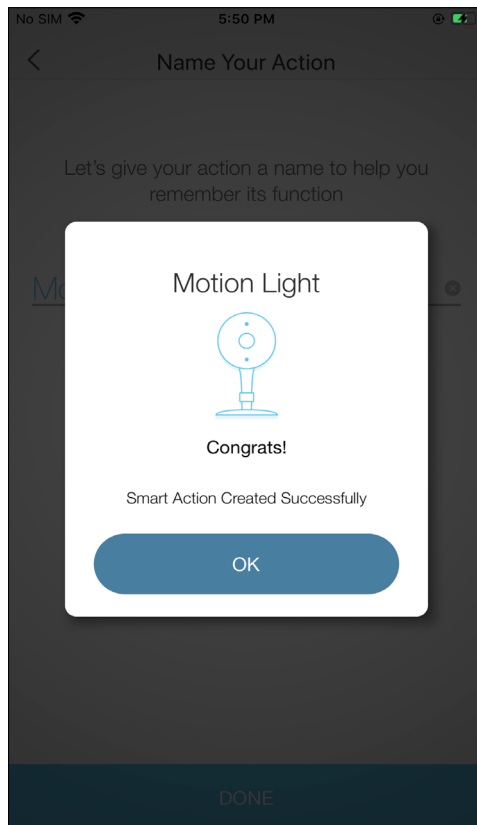

Voice & Third-Party Support

Use the Kasa Smart app to pair your Smart Doorbell with Amazon Alexa or Google Home Assistant, and enjoy a full hands-free experience. Kasa helps manage the rest of your smart home too, working with Samsung SmartThings to trigger changes when you arrive home or leave for the day.

Launch the **Kasa Smart** app. Go to the sidebar and tap [Works with Kasa](#). You can choose [Amazon Alexa](#) / [Google Assistant](#) / [IFTTT](#) / [Samsung SmartThings](#) for detailed instructions.

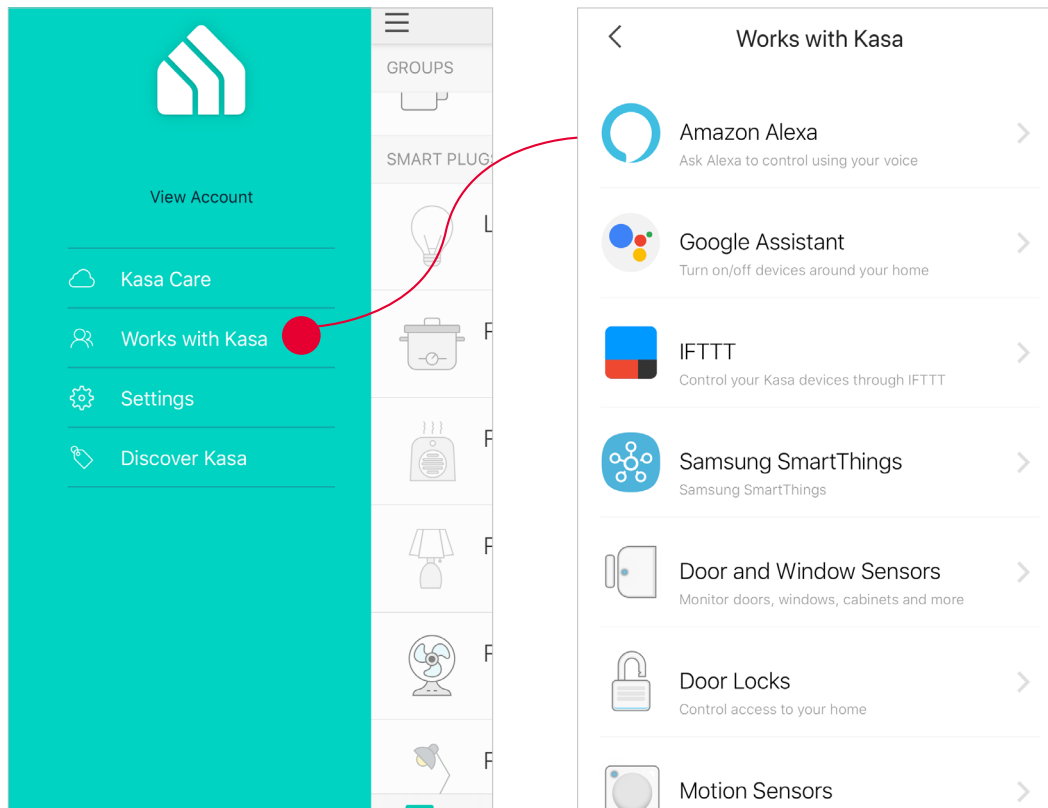

1. Set up Amazon Alexa

1. Tap [Amazon Alexa](#).

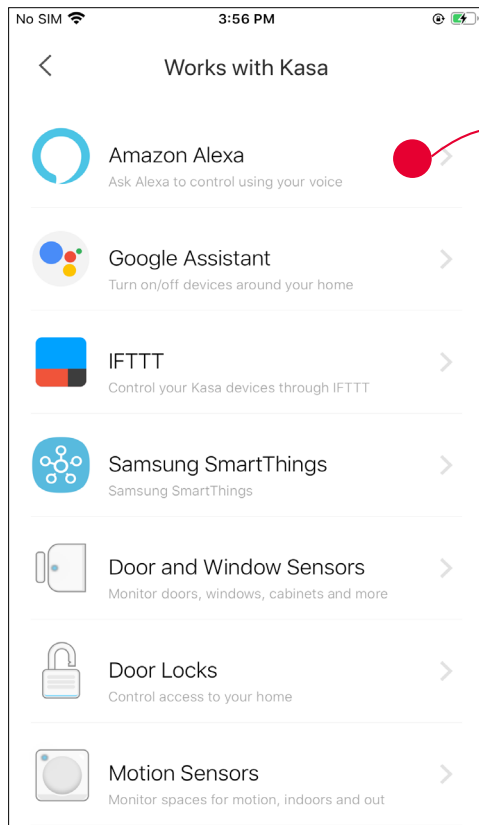

2. Tap [Connect](#).

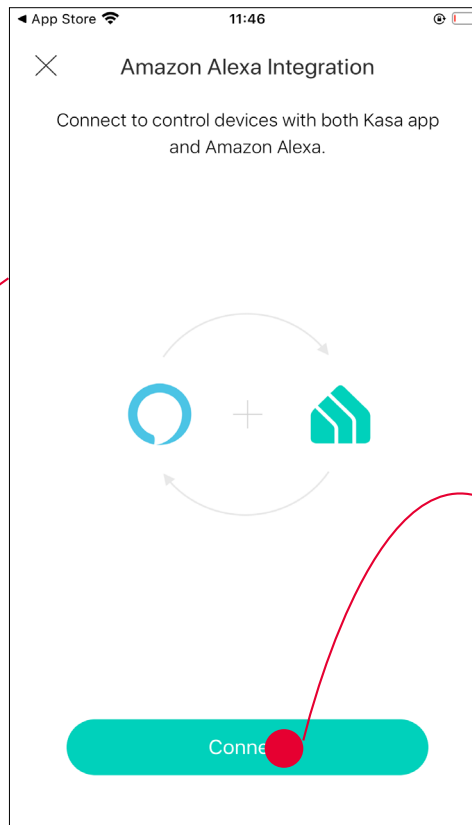

3. Sign in with your amazon account.

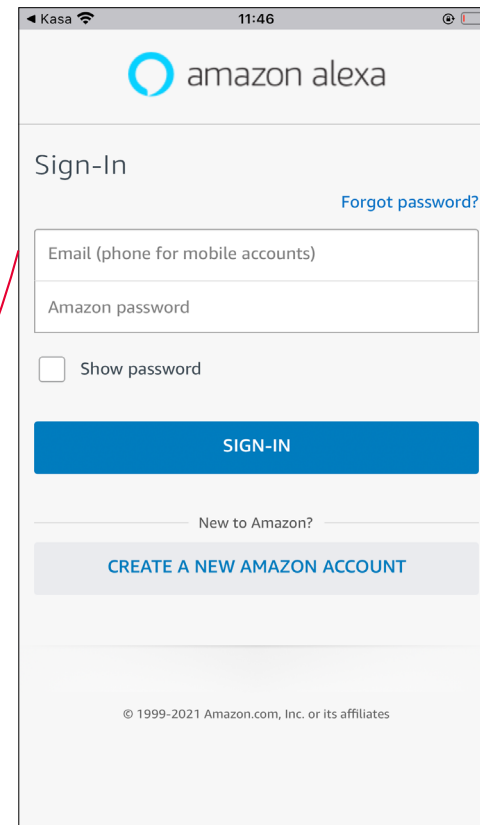

4. After sign-in, tap **LINK**.

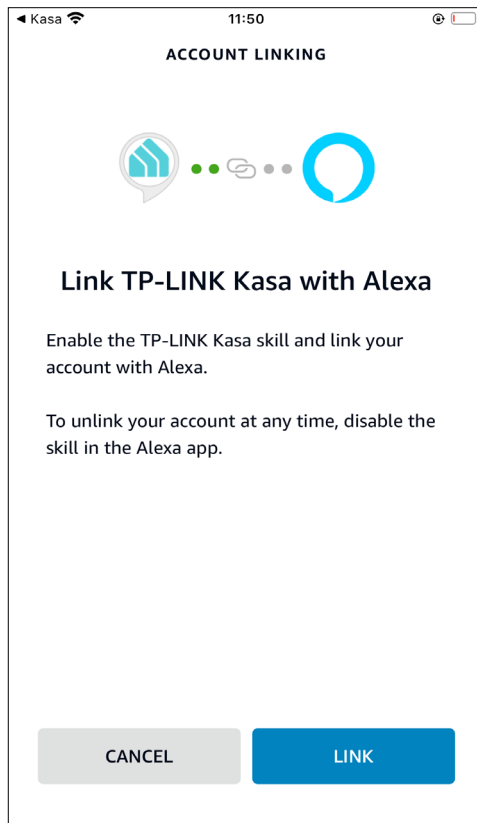

5. Your TP-Link ID has been successfully linked with your amazon account. You can stream the doorbell videos to Amazon Echo Show or Fire TV using simple voice commands.

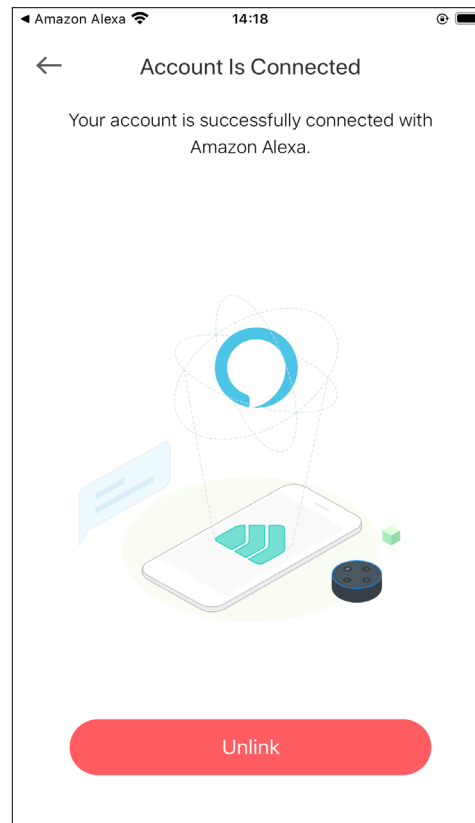

2. Set up Google Assistant

1. Tap [Google Assistant](#).

2. Follow instructions to connect your device to your Google Home.

Or find the FAQ at <https://www.tp-link.com/en/support/faq/1534/>.

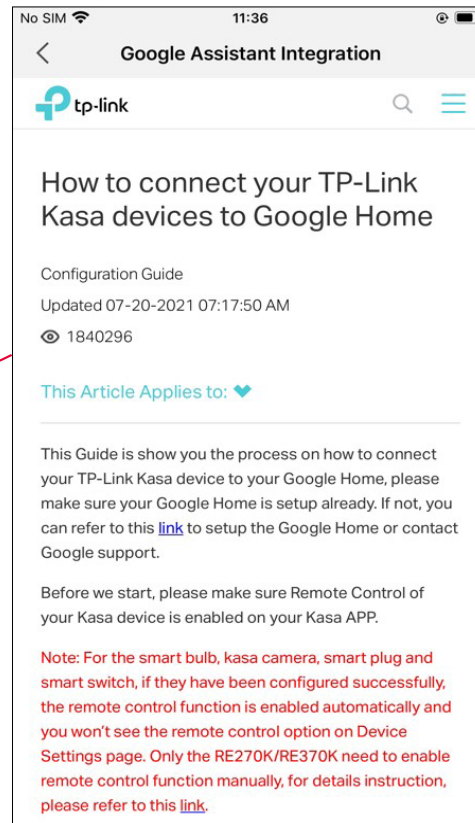
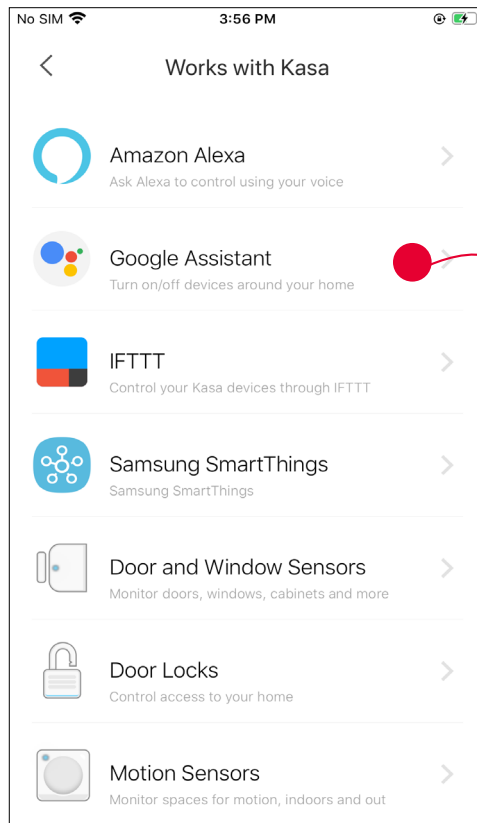

Authentication

FCC compliance information statement



Product Name: Kasa Smart Doorbell

Model Number: KD110

Component Name	Model
Kasa Doorbell Chime	KD110C

Responsible Party:

TP-Link USA Corporation

Address: 10 Mauchly, Irvine, CA 92618

Website: <https://www.tp-link.com/us/>

Tel: +1 626 333 0234

Fax: +1 909 527 6804

E-mail: sales.usa@tp-link.com

This equipment has been tested and found to comply with the limits for a Class B digital device, pursuant to part 15 of the FCC Rules. These limits are designed to provide reasonable protection against harmful interference in a residential installation. This equipment generates, uses and can radiate radio frequency energy and, if not installed and used in accordance with the instructions, may cause harmful interference to radio communications. However, there is no guarantee that interference will not occur in a particular installation. If this equipment does cause harmful interference to radio or television reception, which can be determined by turning the equipment off and on, the user is encouraged to try to correct the interference by one or more of the following measures:

- Increase the separation between the equipment and receiver.
- Connect the equipment into an outlet on a circuit different from that to which the receiver is connected.
- Consult the dealer or an experienced radio/ TV technician for help.

This device complies with part 15 of the FCC Rules. Operation is subject to the following two conditions:

1. This device may not cause harmful interference.
2. This device must accept any interference received, including interference that may cause undesired operation.

Any changes or modifications not expressly approved by the party responsible for compliance could void the user's authority to operate the equipment.

Note: The manufacturer is not responsible for any radio or TV interference caused by unauthorized modifications to this equipment. Such modifications could void the user's authority to operate the equipment.

FCC RF Radiation Exposure Statement

This equipment complies with FCC RF radiation exposure limits set forth for an uncontrolled environment. This device and its antenna must not be co-located or operating in conjunction with any other antenna or transmitter.

"To comply with FCC RF exposure compliance requirements, this grant is applicable to only Mobile Configurations. The antennas used for this transmitter must be installed to provide a separation distance of at least 20 cm from all persons and must not be co-located or operating in conjunction with any other antenna or transmitter."

We, **TP-Link USA Corporation**, has determined that the equipment shown as above has been shown to comply with the applicable technical standards, FCC part 15. There is no unauthorized change is made in the equipment and the equipment is properly maintained and operated.

Issue Date: 2022-01-14

FCC compliance information statement

Product Name: Kasa Doorbell Chime

Model Number: KD110C

Responsible Party:

TP-Link USA Corporation

Address: 10 Mauchly, Irvine, CA 92618

Website: <https://www.tp-link.com/us/>

Tel: +1 626 333 0234

Fax: +1 909 527 6804

E-mail: sales.usa@tp-link.com

This equipment has been tested and found to comply with the limits for a Class B digital device, pursuant to part 15 of the FCC Rules. These limits are designed to provide reasonable protection against harmful interference in a residential installation. This equipment generates, uses and can radiate radio frequency energy and, if not installed and used in accordance with the instructions, may cause harmful interference to radio communications. However, there is no guarantee that interference will not occur in a particular installation. If this equipment does cause harmful interference to radio or television reception, which can be determined by turning the equipment off and on, the user is encouraged to try to correct the interference by one or more of the following measures:

- Increase the separation between the equipment and receiver.
- Connect the equipment into an outlet on a circuit different from that to which the receiver is connected.
- Consult the dealer or an experienced radio/ TV technician for help.

This device complies with part 15 of the FCC Rules. Operation is subject to the following two conditions:

1. This device may not cause harmful interference.
2. This device must accept any interference received, including interference that may cause undesired operation.

Any changes or modifications not expressly approved by the party responsible for compliance could void the user's authority to operate the equipment.

Note: The manufacturer is not responsible for any radio or TV interference caused by unauthorized modifications to this equipment. Such modifications could void the user's authority to operate the equipment.

We, **TP-Link USA Corporation**, has determined that the equipment shown as above has been shown to comply with the applicable technical standards, FCC part 15. There is no unauthorized change is made in the equipment and the equipment is properly maintained and operated.

Issue Date: 2022-01-14

Canadian Compliance Statement

This device contains licence-exempt transmitter(s)/receiver(s) that comply with Innovation, Science and Economic Development Canada's licence-exempt RSS(s). Operation is subject to the following two conditions:

1. This device may not cause interference.
2. This device must accept any interference, including interference that may cause undesired operation of the device.

L'émetteur/récepteur exempt de licence contenu dans le présent appareil est conforme aux CNR d'Innovation, Sciences et Développement économique Canada applicables aux appareils radio exempts de licence. L'exploitation est autorisée aux deux conditions suivantes :

1. l'appareil ne doit pas produire de brouillage;
2. l'utilisateur de l'appareil doit accepter tout brouillage radioélectrique subi, même si le brouillage est susceptible d'en compromettre le fonctionnement

Radiation Exposure Statement:

This equipment complies with IC radiation exposure limits set forth for an uncontrolled environment. This equipment should be installed and operated with minimum distance 20cm between the radiator & your body.

Déclaration d'exposition aux radiations:

Cet équipement est conforme aux limites d'exposition aux rayonnements IC établies pour un environnement non contrôlé. Cet équipement doit être installé et utilisé avec un minimum de 20 cm de distance entre la source de rayonnement et votre corps.

Industry Canada Statement

CAN ICES-3 (B)/NMB-3(B)

Korea Warning Statements:

당해 무선설비는 운용중 전파혼신 가능성이 있음.

NCC Notice & BSMI Notice:

注意!

取得審驗證明之低功率射頻器材，非經核准，公司、商號或使用者均不得擅自變更頻率、加大功率或變更原設計之特性及功能。

低功率射頻器材之使用不得影響飛航安全及干擾合法通信；經發現有干擾現象時，應立即停用，並改善至無干擾時方得繼續使用。

前述合法通信，指依電信管理法規定作業之無線電通信。

低功率射頻器材須忍受合法通信或工業、科學及醫療用電波輻射性電機設備之干擾。

安全諮詢及注意事項

- 請按照本產品注明的電源類型使用本產品。
- 清潔本產品之前請先切斷電源。請勿使用液體、噴霧清潔劑或濕布進行清潔。
- 注意防潮，請勿將水或其他液體潑灑到本產品上。
- 插槽與開口供通風使用，以確保本產品的操作可靠並防止過熱，請勿堵塞或覆蓋開口。
- 請勿將本產品置放於靠近熱源的地方。除非有正常的通風，否則不可放在密閉位置中。
- 不要私自拆開機殼或自行維修，如產品有故障請與原廠或代理商聯繫。

限用物質含有情況標示聲明書

設備名稱： Equipment name Kasa Smart Doorbell		型號（型式）： Type designation (Type) KD110				
單元 Unit	限用物質及其化學符號 Restricted substances and its chemical symbols					
	鉛 Lead (Pb)	汞 Mercury (Hg)	鎘 Cadmium (Cd)	六價鉻 Hexavalent chromium (Cr+6)	多溴聯苯 Polybrominated biphenyls (PBB)	多溴二苯醚 Polybrominated diphenyl ethers (PBDE)
PCB	○	○	○	○	○	○
外殼	○	○	○	○	○	○
電源供應板	—	○	○	○	○	○
其他及其配件	—	○	○	○	○	○

備考 1. “超出 0.1 wt %” 及 “超出 0.01 wt %” 係指限用物質之百分比含量超出百分比含量基準值。

Note 1: “Exceeding 0.1 wt %” and “exceeding 0.01 wt %” indicate that the percentage content of the restricted substance exceeds the reference percentage value of presence condition.

備考 2. “○” 係指該項限用物質之百分比含量未超出百分比含量基準值。

Note 2: “○” indicates that the percentage content of the restricted substance does not exceed the percentage of reference value of presence.

備考 3. “—” 係指該項限用物質為排除項目。

Note 3: The “—” indicates that the restricted substance corresponds to the exemption.



Продукт сертифіковано згідно с правилами системи УкрСЕПРО на відповідність вимогам нормативних документів та вимогам, що передбачені чинними законодавчими актами України.



Safety Information

- Keep the device away from fire or hot environments. DO NOT immerse in water or any other liquid.
- Do not attempt to disassemble, repair, or modify the device. If you need service, please contact us.
- Do not use the device where wireless devices are not allowed.
- Cut off the power supply to the transformer before installation to avoid accidental short-circuit of transformer output leads.
- The product must be installed and used in accordance with the National Electric Code (NEC) or your local electrical code. If you are unfamiliar with these codes and requirements, or are uncomfortable performing the installation, consult a qualified electrician.

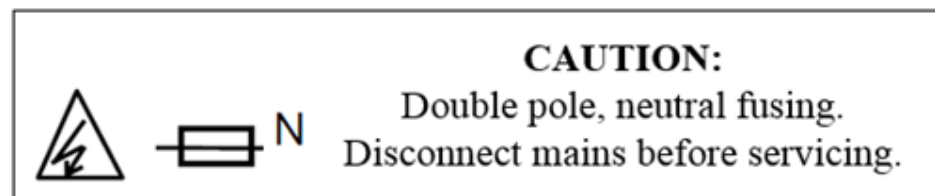









Please read and follow the above safety information when operating the device. We cannot guarantee that no accidents or damage will occur due to improper use of the device. Please use this product with care and operate at your own risk.

Warnings

- Operating Temperature for Chime: 0°C-40 °C (32°F-104°F)
- Operating Temperature for Doorbell: -20°C-45 °C (-4°F-113°F)

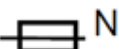
Explanation of the symbols on the product label

Symbol	Explanation
	Direct current
	Alternating current
	Indoor use only
	Class II equipment
	<p>RECYCLING</p> <p>This product bears the selective sorting symbol for Waste electrical and electronic equipment (WEEE). This means that this product must be handled pursuant to European directive 2012/19/EU in order to be recycled or dismantled to minimize its impact on the environment.</p> <p>User has the choice to give his product to a competent recycling organization or to the retailer when he buys a new electrical or electronic equipment.</p>
	Caution, risk of electric shock
	Fuse is used in neutral N
	Caution

Symbol	Explanation
	Operator's manual