

1-Port XGS-PON Terminal

MODEL: XGZ030 2.0

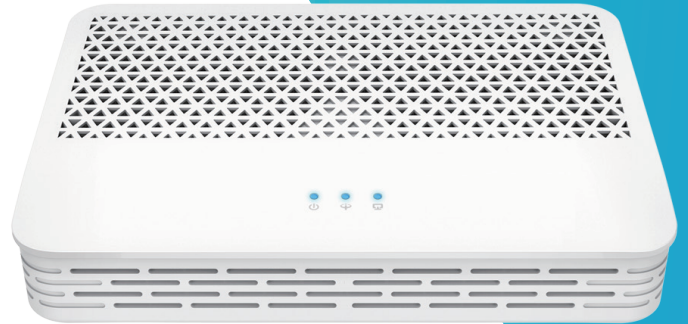

Overview

TP-Link's XGZ030 XGS-PON Terminal provides up to 10 Gbps of uplink and downlink bandwidth simultaneously. It meets the higher bandwidth demand of various high-bandwidth services. It also reduces both capital and operating expenditure, protecting ISPs' existing infrastructure investments.



10G Wired Performance

Supports XGS-PON + 10 Gbps LAN port to enable ultra-fast 10G network connections



Bridge Mode

High-speed transparent transmission for the best signal



Remote Management

Supports OMCI, enables an operator to remotely configure and manage end-user devices



BOSA on Board Design

Support SC/APC port

Features



High Speed

Downstream and upstream rates up to 10Gbps



Easy Management

Supports OMCI (ONT Management Control Interface) remote management



Ease of Use

Quick and hassle-free installation
Intelligent power-saving method

Network Topology

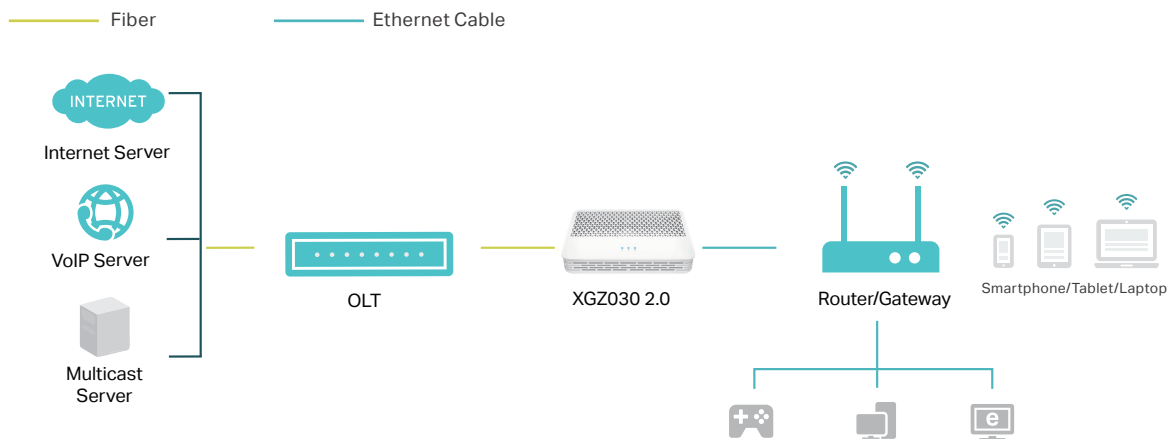

Hardware Description

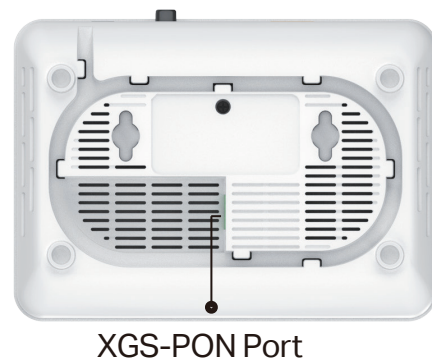
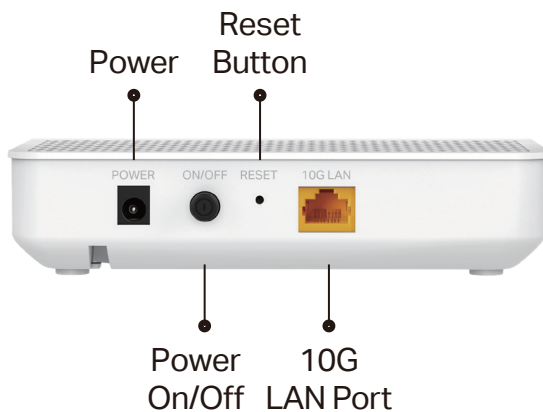

Specifications

Hardware

- **Interface**
1× 10GE LAN Port, 1× XGS-PON Port
- **Button**
Power On/Off Button, Reset Button
- **External Power Supply**
12V/1A
- **Dimensions (W * D * H)**
6.19 × 4.42 × 1.46 in (157.2 × 112.4 × 37.0 mm)
- **Optical Module**
Class E1
- **GPON Standards**
ITU-T G.9807.1, ITU-T G.988
- **Transmitter**
DFB Laser
- **Receiver**
PIN-TIA
- **Data Rate**
Upstream: 10 Gbps, Downstream: 10 Gbps
- **Wavelength**
Upstream: 1270nm, Downstream: 1577nm
- **Distance**
0 ~ 20Km Max
- **Flash**
128M NAND Flash
- **RAM**
128M DDR3

Software

- **VLAN**
802.1Q tag VLAN, Q in Q VLAN
VLAN transparent mode/VLAN translation mode/VLAN trunk mode
Authentication based on SN and Password
- **IGMP**
IGMP v1/v2/v3
- **Security**
AES Encryption, Packet Filter based on VLAN
- **Management**
Managed by Web, OMCI and Telnet,
Specified the management IP,
Reset to Factory default by Reset button or Web UI, Real-time statistics,
Optical Diagnostic, Dual Image,
Schedule Reboot, LED Schedule
- **Advanced Functions**
Upstream and Downstream FEC,
Dynamic Bandwidth Allocation(DBA) support NSR/SR,
Up to 32 T-CONTs and 256 GEM Ports,
Optical power detection, Dying Gasp,
Terminal Silent mechanism,
802.3az EEE Energy Conservation

Others

- **Certification**
CE, FCC, RoHS
- **Environment**
Operating Temperature: 0°C~40°C (32°F~104°F),
Storage Temperature: -40°C~60°C (-40°F ~140°F)
- **Package Contents**
1-Port XGS-PON Terminal XGZ030
Power Adapter
Quick Installation Guide